



VILLAGE OF ORLAND PARK

14700 Ravinia Avenue
Orland Park, IL 60462
www.orland-park.il.us

Meeting Agenda

Parks and Recreation Committee

*Chairman Patricia A. Gira
Trustees Kathleen M. Fenton and Daniel T. Calandriello
Village Clerk John C. Mehalek*

Monday, September 19, 2016

6:00 PM

Village Hall

A. CALL TO ORDER/ROLL CALL

B. APPROVAL OF MINUTES

2016-0662 Approval of the August 15, 2016 Parks and Recreation Minutes

Attachments: [Draft Minutes](#)

C. ITEMS FOR SEPARATE ACTION

1. **2016-0649** Homer Industries Invoices

Attachments: [Invoices](#)

2. **2016-0650** Park Hill Pond 1 (north side) and Park Hill Pond 3 (north side)
Shoreline Restoration and Stabilization

Attachments: [V3 - Park Hill Ponds](#)
[Pizzo Park Hill Proposal](#)

3. **2016-0651** CPAC Inlet Replacement Bid #16-028 Award

Attachments: [Crossroad Construction Bid](#)
[Bid 16-028 Tabulation](#)

4. **2016-0652** Laurel Hills Basketball/Tennis Court Repairs

Attachments: [US Tennis Court Quote](#)

5. **2016-0653** Greystone Ridge Park Identification Sign

Attachments: [Parkreation Quote & Drawing](#)

6. **2016-0644** 2016 Turkey Trot Race Shirt Purchase Approval

Attachments: [Quotes](#)

D. NON-SCHEDULED CITIZENS & VISITORS

E. ADJOURNMENT

DATE: September 19,
2016

REQUEST FOR ACTION REPORT

File Number: **2016-0662**
Orig. Department: **Village Clerk**
File Name: **Approval of the August 15, 2016 Parks and Recreation Minutes**

BACKGROUND:

BUDGET IMPACT:

REQUESTED ACTION:

I move to approve the Minutes of the Regular Meeting of the Parks and Recreation Committee of August 15, 2016.

VILLAGE OF ORLAND PARK

14700 Ravinia Avenue
Orland Park, IL 60462
www.orland-park.il.us



Meeting Minutes

Monday, August 15, 2016

6:00 PM

Village Hall

Parks and Recreation Committee

*Chairman Patricia A. Gira
Trustees Kathleen M. Fenton and Daniel T. Calandriello
Village Clerk John C. Mehalek*

CALL TO ORDER/ROLL CALL

The meeting was called to order at 6:00 P.M.

Present: 3 - Chairman Gira; Trustee Fenton and Trustee Calandriello

APPROVAL OF MINUTES

2016-0568 Approval of the July 18, 2016 Parks and Recreation Minutes

I move to approve the Minutes of the Regular Meeting of the Parks and Recreation Committee of July 18, 2016.

A motion was made by Trustee Calandriello, seconded by Trustee Fenton, that this matter be APPROVED. The motion carried by the following vote:

Aye: 3 - Chairman Gira, Trustee Fenton, and Trustee Calandriello

Nay: 0

ITEMS FOR SEPARATE ACTION

2016-0574 Recreation Department Program Guide - Winter/Spring 2017 Programs

Recreation Director Nancy Flores reported that the lists of recommended programs to be offered in the Recreation Department 2017 Winter/Spring Program Guide are attached to the Committee Packet. Included in the lists are contractual costs (over \$5,000) that would need Board approval associated with the winter/spring sessions. These costs are covered by revenue generated through registration fees and actual costs are dependent on the number of participants registered.

Staff is requesting approval of the recommended programs and payment to the contractual instructors at time of invoicing.

I move to recommend to the Village Board to approve the recommended programs and payment to the contractual instructors at time of invoicing.

A motion was made by Trustee Calandriello, seconded by Trustee Fenton, that this matter be RECOMMENDED FOR APPROVAL to the Board of Trustees. The motion carried by the following vote:

Aye: 3 - Chairman Gira, Trustee Fenton, and Trustee Calandriello

Nay: 0

ADJOURNMENT: 6:03 P.M.

A motion was made by Trustee Fenton, seconded by Trustee Calandriello, that this matter be ADJOURNED. The motion carried by the following vote:

Aye: 3 - Chairman Gira, Trustee Fenton, and Trustee Calandriello

Nay: 0

/AS

Respectfully Submitted,

John C. Mehalek, Village Clerk

DATE: September 19,
2016

REQUEST FOR ACTION REPORT

File Number: **2016-0649**
Orig. Department: **Parks Department**
File Name: **Homer Industries Invoices**

BACKGROUND:

The Parks department utilizes Homer Industries to provide mulch and Nature's Blanket which is the playground safety surfacing (meets ASTM standards). The majority of the purchasing of this material is conducted during our peak summer months while the department has seasonal staff to assist with the installation of the material. Material is delivered in bulk by the semi load and installed at park sites.

Each park, depending on the size, will be approximately \$1,400 per semi load.

As a result, the total cost of the product has gone above \$5,000 and therefore, is required to have board approval. The current amount due is \$13,612.50. There are several more deliveries scheduled prior to the end of the year. Staff is requesting board approval to pay the current invoices and to pay any additional invoices submitted.

Staff will be going out to bid for this service in FY17.

BUDGET IMPACT:

Funds are budgeted in account 283-4003-461600

REQUESTED ACTION:

I move to recommend to the Village Board to accept payment of invoices for Homer Industries in the amount of \$13,612.50, and to spend up to board approved budgeted amount of \$20,747.00.

Homer Industries

13920 S Archer Ave
Lockport, IL 60441-7447

Phone (815)838-0863 Fax (815)838-0378

Customer ID ORLAND-145

Gary
ORLAND PARK PARKS DEPT
14560 RAVINIA AVE.
ORLAND PARK, IL 60462

Phone (708)362-1284

Statement

Date 09/01/2016

Page # 1

Invoice#	Invoice Date	Amount	Current	Invoiced on or before		
				08/01/2016	07/01/2016	06/01/2016
S90958	06/27/2016	1,402.50	0.00	0.00	1,402.50	0.00
S91002	06/27/2016	1,402.50	0.00	0.00	1,402.50	0.00
S91456	07/05/2016	1,402.50	0.00	1,402.50	0.00	0.00
S91610	07/07/2016	1,402.50	0.00	1,402.50	0.00	0.00
S91843	07/12/2016	1,402.50	0.00	1,402.50	0.00	0.00
S91960	07/14/2016	1,402.50	0.00	1,402.50	0.00	0.00
S92074	07/18/2016	1,320.00	0.00	1,320.00	0.00	0.00
S92324	07/21/2016	1,320.00	0.00	1,320.00	0.00	0.00
S92494	07/26/2016	1,320.00	0.00	1,320.00	0.00	0.00
S92549	07/28/2016	1,320.00	0.00	1,320.00	0.00	0.00
S92634	08/01/2016	1,320.00	0.00	1,320.00	0.00	0.00
Net total for customer		15,015.00	0.00	12,210.00	2,805.00	0.00

Last Payment Amount 240.00
Last Payment Date 08/19/2016

DATE: September 19,
2016

REQUEST FOR ACTION REPORT

File Number: **2016-0650**
Orig. Department: **Parks Department**
File Name: **Park Hill Pond 1 (north side) and Park Hill Pond 3 (north side) Shoreline Restoration and Stabilization**

BACKGROUND:

In 2011 the Village established the Basin and Best Practices Management report. The report contains bids and evaluations on Village ponds and areas that require stewardship to ensure proper functionality and aesthetics of said areas. Since the completion of the report, the Village has worked with contractors to perform the required services.

The selected companies were chosen based on price and expertise in the area of ecological restoration. As a result, V3 is one of the companies that were awarded basin and restoration work.

V3 has proven to be extremely knowledgeable in this area of work and have provided exemplary service to the Village on high profile pond and natural area projects.

Due to erosion and shoreline instability, staff reached out to several companies for proposals to repair and prevent further issues. Due to the original costs received, staff requested revised proposals to complete the needed work in phases. Proposals were received from Pizzo & Associates LTD. in the amount of \$148,649.70 and from V3 Construction Group in the amount of \$154,178.25.

The proposal from V3 is a higher cost and covers less linear feet than the Pizzo proposal, however the scope provided a more extensive approach to solving the erosion and instability issues. The services include an educational component (community meeting for residents in the affected area) as well as informational handouts (printing and distribution) to help increase the understanding of the work and how and why it is being performed and what residents should expect to be accomplished.

In addition, V3 has included a stewardship of the areas for three years which provides the Village some savings as well. V3 has provided superior expertise and service, greatly improving the functionality and appearance of the natural plantings at multiple Village pond sites. The scope of the work including the stewardship of the sites are attached

BUDGET IMPACT:

Funds are budgeted for the project in account 031-6007-443500

REQUESTED ACTION:

I move to recommend to the Village Board to accept Shoreline Restoration and Stabilization of Park Hill Pond 1 (north side 550LF) and Park Hill Pond 3 (north side 280LF), including the

proposed 3 year stewardship (2017, 2018, 2019) for each site to V3 Construction Group LTD. at a total cost not to exceed \$154,178.25.



To: Village of Orland Park Address: 14700 Ravinia Avenue Orland Park, Illinois 60462	Contact: Gary Couch Phone: 708-403-6150 Email: gcouch@orlandpark.org
Project Name: Parkview Pond Restoration & Stabilization Location: Orland Park, Illinois	Ref #: B16-098 Date: 8/25/2016 Estimator: Tom Foster

V3 Construction Group, Ltd. proposes to execute the following work:

STABILIZATION & NATIVE RESTORATION PROPOSAL

1.00	PARKVIEW POND WEST (550 LF)	\$	74,957.50
2.00	PARKVIEW POND EAST (280LF)	\$	79,220.75
PROPOSAL TOTAL:			\$ 154,178.25

Project Notes:

- 1.0 This proposal is valid for 30 days.
- 2.0 This proposal is to provide slope re-grading and installation of vegetated soil lifts for two detention basins in Orland Park.
- 3.0 We have not provided as-built drawings. It is our understanding that the work detailed below is considered maintenance and will not require any permitting. Permit drawings / fees are not provided in this estimate.
- 4.0 This proposal specifically excludes: bonds, permits, special insurance (waiver of subrogation, pollution liability insurance), and testing including QC/QA, handling or disposal of hazardous materials or non-hazardous special waste material, & compaction or material testing.
- 5.0 This is a "balance site" proposal. No monies are included for the removal or import of soil material. It is our understanding that sufficient topsoil is present in the slopes to provide for soil wrap installation & backfill.
- 6.0 It is V3's assessment that the Work to be performed pursuant to this Contract is neither the construction nor demolition of public works and therefore the Illinois Prevailing Wage Act does not apply to the Work to be performed pursuant to this Contract. If the Illinois Prevailing Wage Act applies to the Work, V3 reserves the right to adjust pricing.
- 7.0 This is a lump sum proposal for the scope indicated. Unit rates and quantities are provided to illustrate intended project scope and provided a basis for negotiating change orders in the event that scope is added or deleted from the contract.

Payment & Contract Notes:

- 1.0 Unless otherwise specified, the quantities for the items listed above are estimated only. Payment will be based on the final quantities installed and the applicable unit prices.
- 2.0 Net payment is due upon receipt of invoice.
- 3.0 Invoices unpaid after thirty (30) days will incur a finance charge of three percent (3.0%) per month.
- 4.0 Final payment, including any retained monies, is due immediately upon satisfactory completion of the work and receipt by purchaser of the final invoice.
- 5.0 This contract is limited to the work identified. Any additional work will be agreed to by change order and made a part of this agreement.
- 6.0 This contract shall be interpreted under the laws of the State of Illinois.

ACCEPTED: <i>The above prices, specifications and conditions are satisfactory and hereby accepted.</i>	CONFIRMED: <i>The above prices, specifications and conditions are satisfactory and hereby confirmed.</i>
Purchaser: <u>Village of Orland Park</u>	Seller: <u>V3 Construction Group, Ltd.</u>
Signature: _____	Signature: _____
Printed Name: _____	Printed Name: _____
Date: _____	Date: _____



To: Village of Orland Park Address: 14700 Ravinia Avenue Orland Park, Illinois 60462	Contact: Gary Couch Phone: 708-403-6150 Email: gcouch@orlandpark.org
Project Name: Parkview Pond Restoration & Stabilization Location: Orland Park, Illinois	Ref #: B16-098 Date: 8/25/2016 Estimator: Tom Foster

1.00 PARKVIEW POND WEST (550 LF)	QUANTITY	UNIT	UNIT PRICE	TOTAL
1.10 GENERAL CONDITIONS				
1.11 Mobilization	1.000	LSUM	\$ 8,300.00	\$ 8,300.00
1.12 Community Education Meeting	1.000	EACH	\$ 350.00	\$ 350.00
1.13 Informational Pamphlet (Printing & Distribution)	1.000	LSUM	\$ 130.00	\$ 130.00
1.20 DEMOLITION				
1.21 Hand Clearing & Vegetation Removal	1.000	LSUM	\$ 3,300.00	\$ 3,300.00
1.22 Boom Spray - Non Residual / Non-Selective	1.000	ACRE	\$ 110.00	\$ 110.00
1.30 STABILIZATION				
1.32 Turbidity Curtain Installation	550.000	LF	\$ 5.50	\$ 3,025.00
1.33 Regrade Slope (3.00')	200.000	LF	\$ 78.00	\$ 15,600.00
1.34 Regrade Slope (1.50')	350.000	LF	\$ 25.00	\$ 8,750.00
1.40 RESTORATION				
1.41 Seedbed Preparation	0.700	ACRE	\$ 2,300.00	\$ 1,610.00
1.42 Native Seeding	0.350	ACRE	\$ 5,000.00	\$ 1,750.00
1.43 Turf Seeding	0.350	ACRE	\$ 2,600.00	\$ 910.00
1.44 Erosion Control Blanket Installation	3,390.000	SY	\$ 2.50	\$ 8,475.00
1.45 Plug Installation (GT 38)	2,800.000	EACH	\$ 4.50	\$ 12,600.00
1.46 Access Route (Seed & Blanket)	655.000	SY	\$ 6.50	\$ 4,257.50
1.50 NATIVE AREAS MANAGEMENT				
1.51 Weed Control (3 Years)	3.000	YEAR	\$ 930.00	\$ 2,790.00
1.52 Monitoring & Reporting	3.000	YEAR	\$ 1,000.00	\$ 3,000.00
SUBTOTAL				\$ 74,957.50

2.00 PARKVIEW POND EAST (280 LF)	QUANTITY	UNIT	UNIT PRICE	TOTAL
2.10 GENERAL CONDITIONS				
2.11 Mobilization	1.000	LSUM	\$ 5,950.00	\$ 5,950.00
2.12 Community Education Meeting	1.000	EACH	\$ 350.00	\$ 350.00
2.13 Informational Pamphlet (Printing & Distribution)	1.000	LSUM	\$ 130.00	\$ 130.00
2.20 DEMOLITION				
2.21 Hand Clearing & Vegetation Removal	1.000	LSUM	\$ 6,000.00	\$ 6,000.00
2.22 Boom Spray - Non Residual / Non-Selective	1.000	LSUM	\$ 110.00	\$ 110.00
2.30 STABILIZATION				
2.31 Turbidity Curtain Installation	280.000	LF	\$ 5.25	\$ 1,470.00
2.32 Install Double Soil Wrap	95.000	LF	\$ 95.70	\$ 9,091.50
2.33 Install Triple Soil Wrap	206.450	LF	\$ 115.00	\$ 23,741.75
2.34 Install Stone Toe (Soil Wrap)	280.000	LF	\$ 45.00	\$ 12,600.00
2.35 Extend & Reset Existing 18" FES	1.000	EACH	\$ 3,500.00	\$ 3,500.00
2.40 RESTORATION				
2.41 Seedbed Preparation	0.300	ACRE	\$ 2,300.00	\$ 690.00
2.42 Native Seeding	0.100	ACRE	\$ 5,000.00	\$ 500.00
2.43 Turf Seeding	0.200	ACRE	\$ 2,600.00	\$ 520.00
2.44 Erosion Control Blanket Installation	975.000	SY	\$ 2.50	\$ 2,437.50
2.45 Plug Installation (GT 38)	1,120.000	EACH	\$ 4.50	\$ 5,040.00
2.46 Access Route (Seed & Blanket)	200.000	SY	\$ 6.50	\$ 1,300.00
2.50 NATIVE AREAS MANAGEMENT				
2.51 Weed Control (3 Years)	3.000	YEAR	\$ 930.00	\$ 2,790.00
2.52 Monitoring & Reporting	3.000	YEAR	\$ 1,000.00	\$ 3,000.00
SUBTOTAL				\$ 79,220.75



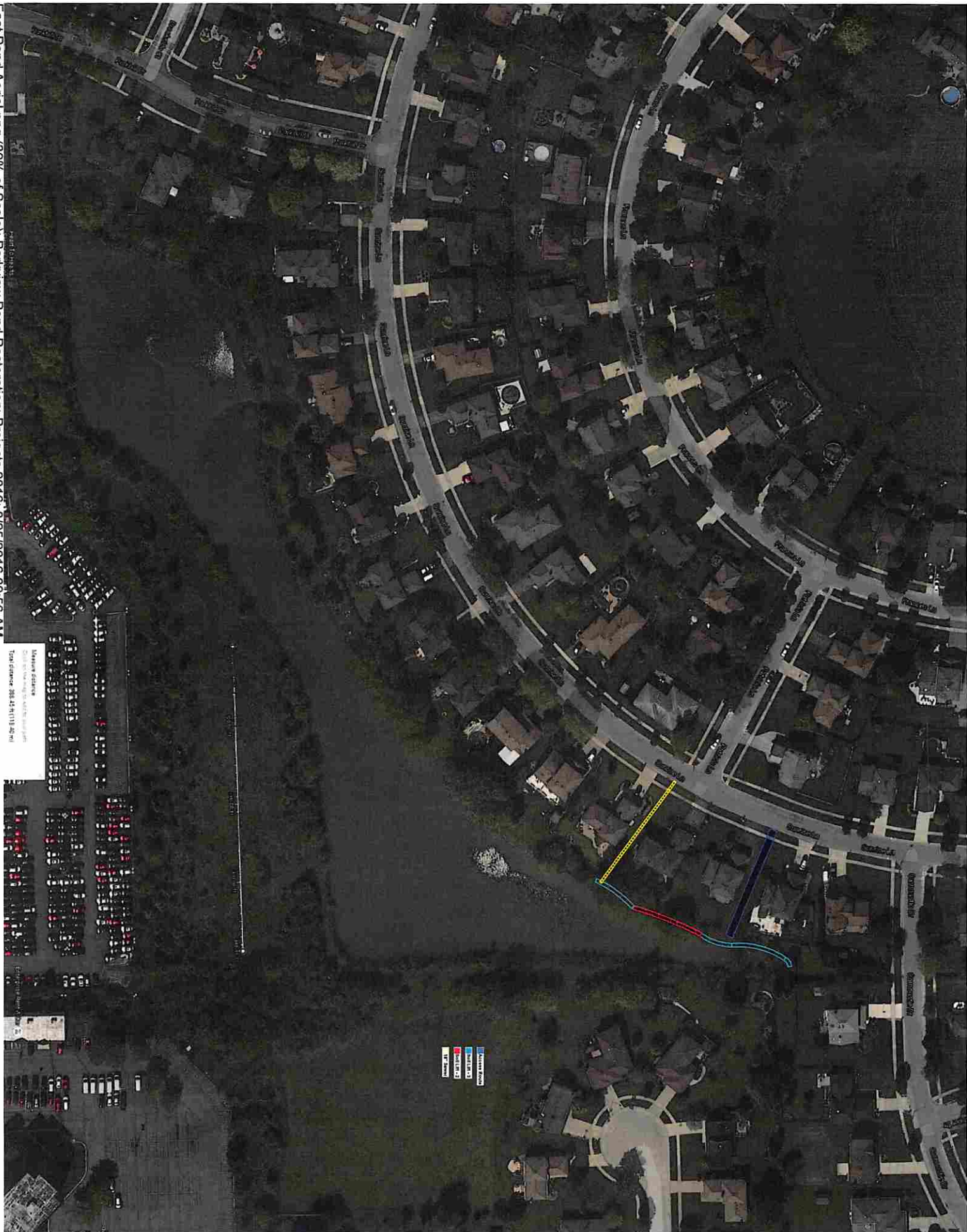

Parkway Pond
Parkway Rd
Parkway

East Pond Aerial.png (39% of Scale); Parkview Pond Restoration; Projects 2016; 8/25/2016 09:56 AM

MapView Software
© 2016 MapView Software, Inc.
Total Distance: 388.42 (4113.80 mi)

PROPOSAL FOR WORK

PIZZO & ASSOCIATES, LTD.

Ecological Restoration & Planning
 10729 Pine Road
 Leland, IL 60531
 PH: 815.495.2300 / FX: 815.498.4406

Project Number:	114035-00-ORLA
Project Ecologist:	Jack Pizzo
Mobile Phone:	815-351-3250
e-mail Address:	jackp@pizzo.info

PROJECT:

Project Name:	Village of Orland Park
Project Address:	Parkhill Ponds 1 & 3 Orland Park, IL

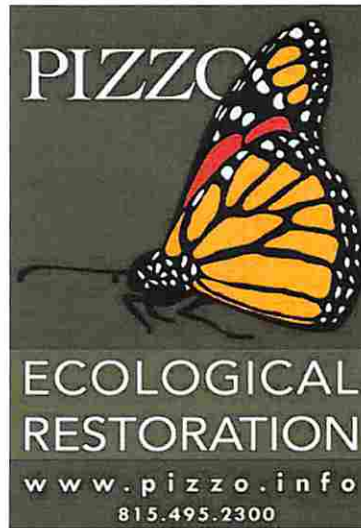

WORK SHALL INCLUDE:

Solution to ongoing maintenance issue of erosion of the shoreline.
 Site: Appx. 850 and 1100 l.f. of shoreline on Ponds 1 and 3.
 Services: Clear invasive brush, apply herbicide to invasive weeds., light regrade erosion to a to make plantable areas where needed, install erosion control blanket where needed, enhance the existing planting with native seeds /plants and install goose control netting

PARK HILL POND #1 MAINTENANCE

Item #	Item Description	Unit	Qty	Unit price	Lump Sum Cost
1	Parkhill Pond 1 - North Side (~850 LF)	LS	1	\$74,495.32	\$74,495.32
TOTAL	BASE BID				\$ 74,495.32

PARK HILL POND #3 MAINTENANCE

Item #	Item Description	Unit	Qty	Unit price	Lump Sum Cost
1	Parkhill Pond 3 - North Side (~1100 LF)	LS	1	\$74,154.37	\$74,154.37
TOTAL	BASE BID				\$ 74,154.37

Note: This proposal is based on a single mobilization; subsequent mobilizations may incur additional costs.

\$ 148,649.70

AGREEMENT:

I/we represent and warrant that I/we have authority to enter into this Contract. We accept the aforementioned and further accept the PIZZO & ASSOCIATES, LTD. STANDARD TERMS AND CONDITIONS, attached and hereby made part of this contract. We do hereby authorize Pizzo & Associates, Ltd. to perform the work as stated.

 Gary Couch
 Village of Orland Park

Date:

 Jack Pizzo
 Pizzo & Associates, Ltd.

Date: 9/6/2016

The terms of this proposal are valid for thirty (30) days from the date of this proposal

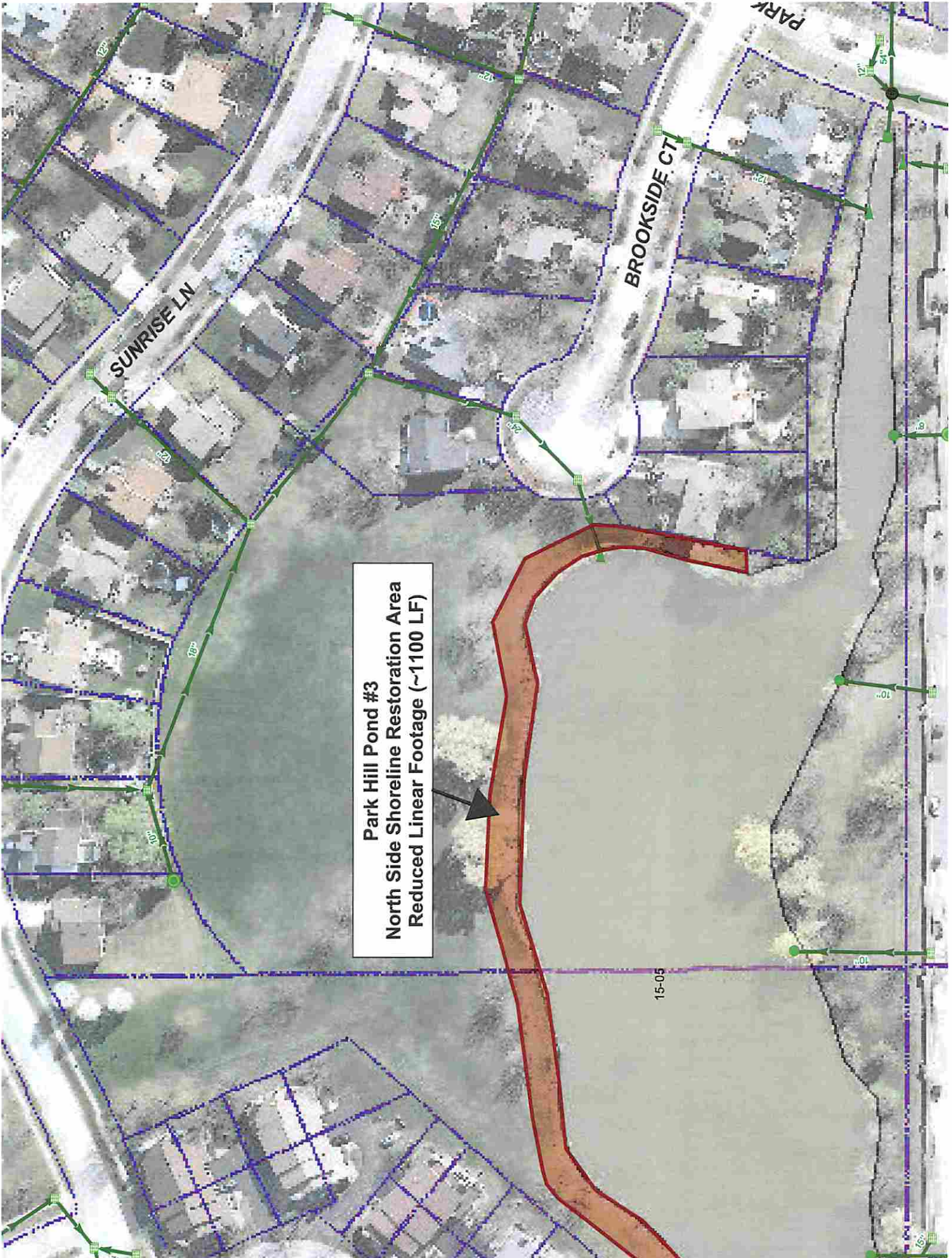

**Park Hill Pond #3
North Side Shoreline Restoration Area
Reduced Linear Footage (~1100 LF)**

SUNRISE LN

BROOKSIDE CT

PARK

15-05

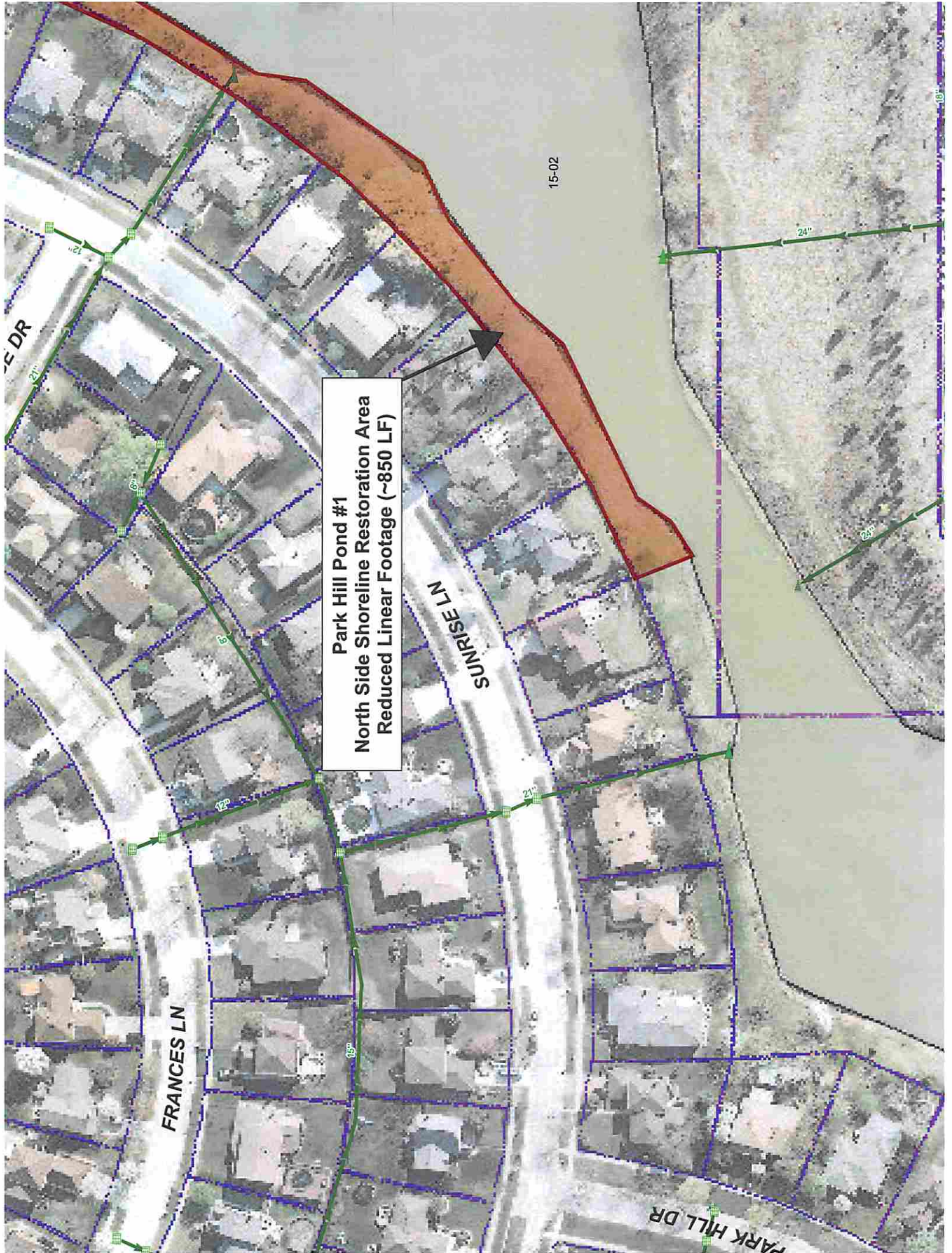

**Park Hill Pond #1
North Side Shoreline Restoration Area
Reduced Linear Footage (~850 LF)**

15-02

SUNRISE LN

FRANCES LN

PARK HILL DR

DR

12'

12'

12'

15'

21'

24'

24'

18'

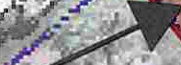

DATE: September 19,
2016

REQUEST FOR ACTION REPORT

File Number: **2016-0651**
Orig. Department: **Parks Department**
File Name: **CPAC Inlet Replacement Bid #16-028 Award**

BACKGROUND:

An invitation to bid was issued on August 23, 2016 for the removal and replacement of seventy five inlets in the pools at Centennial Park Aquatic Center. The bid was opened on September 8, 2016 with one company submitting a bid.

Crossroad Construction, Inc. submitted a responsive bid of \$450.00 per unit for a total of \$31,480.00. This project needs to be completed this fall as weather is always an issue in the spring and to ensure the pool is ready to open on time.

BUDGET IMPACT:

Funds were budgeted for this project. The bid came in \$4,180 over the budgeted amount, but sufficient funds are available to cover the cost difference in account 283-4005-460180.

REQUESTED ACTION:

I move to recommend to the Village Board to accept bid #16-028 at a cost not to exceed \$31,480 from Crossroad Construction, Inc. for the Inlet replacement at Centennial Park Aquatic Center.

Original

BIDDER SUMMARY SHEET

Bid #16-028 CPAC Inlet Replacement
Project Name

Business Name: Crossroad Construction, Inc.

Street Address: 1N725 Swift Road

City, State, Zip: Lombard, IL 60148

Contact Name: Salvatore Gruttadauro

Title: Project Manager

Phone: 630-847-9400 Fax: 630-627-9601

E-Mail address: Tony.crossroad@gmail.com

PRICE PROPOSAL

GRAND TOTAL BID PRICE for 75 Inlet Replacements	\$ <u>31,480⁰⁰</u>
Remove and Replace one (1) Inlet Jet	\$ <u>450⁰⁰</u> per unit

AUTHORIZATION & SIGNATURE

Name of Authorized Signee: Salvatore Gruttadauro

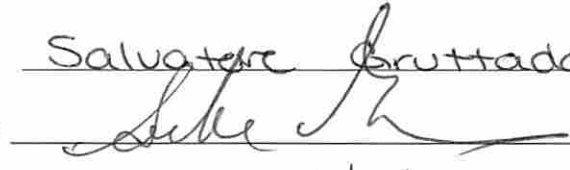
Signature of Authorized Signee: 

Title: President Date: 9/8/14

AFFIDAVIT OF COMPLIANCE

Bidders shall complete this Affidavit of Compliance. Failure to comply with all submission requirements may result in a determination that the Bidder is not responsible.

The undersigned Salvatore Gruttadauro,
(Enter Name of Person Making Affidavit)

as President
(Enter Title of Person Making Affidavit)

and on behalf of Crossroad Construction, Inc.
(Enter Name of Business Organization)

certifies that Bidder is:

1) A BUSINESS ORGANIZATION: Yes No

Federal Employer I.D. #: 45-3193391
(or Social Security # if a sole proprietor or individual)

The form of business organization of the Bidder is (check one):

- Sole Proprietor
- Independent Contractor (Individual)
- Partnership
- LLC
- Corporation Illinois May 1, 2011
(State of Incorporation) (Date of Incorporation)

2) AUTHORIZED TO DO BUSINESS IN ILLINOIS: Yes No

The Bidder is authorized to do business in the State of Illinois.

3) ELIGIBLE TO ENTER INTO PUBLIC CONTRACTS: Yes No

The Bidder is eligible to enter into public contracts, and is not barred from contracting with any unit of state or local government as a result of a violation of either Section 33E-3, or 33E-4 of the Illinois Criminal Code, or of any similar offense of "bid-rigging" or "bid-rotating" of any state or of the United States.

4) SEXUAL HARRASSMENT POLICY COMPLIANT: Yes No

Please be advised that Public Act 87-1257, effective July 1, 1993, 775 ILCS 5/2-105 (A) has been amended to provide that every party to a public contract must have a written sexual harassment policy in place in full compliance with 775 ILCS 5/2-105 (A) (4) and includes, at a minimum, the following information:

(I) the illegality of sexual harassment; (II) the definition of sexual harassment under State law; (III) a description of sexual harassment, utilizing examples; (IV) the vendor's internal complaint process including penalties; (V) the legal recourse, investigative and complaint process available through the Department of Human Rights (the "Department") and the Human Rights Commission (the "Commission"); (VI) directions on how to contact the Department and Commission; and (VII) protection against retaliation as provided by Section 6-101 of the Act. (Illinois Human Rights Act). (emphasis added). Pursuant to 775 ILCS 5/1-103 (M) (2002), a "public contract" includes "...every contract to which the State, any of its political subdivisions or any municipal corporation is a party."

5) EQUAL EMPLOYMENT OPPORTUNITY COMPLIANT: Yes No

During the performance of this Project, Bidder agrees to comply with the "Illinois Human Rights Act", 775 ILCS Title 5 and the Rules and Regulations of the Illinois Department of Human Rights published at 44 Illinois Administrative Code Section 750, et seq.

The Bidder shall:

(I) not discriminate against any employee or applicant for employment because of race, color, religion, sex, marital status, national origin or ancestry, age, or physical or mental handicap unrelated to ability, or an unfavorable discharge from military service; (II) examine all job classifications to determine if minority persons or women are underutilized and will take appropriate affirmative action to rectify any such underutilization; (III) ensure all solicitations or advertisements for employees placed by it or on its behalf, it will state that all applicants will be afforded equal opportunity without discrimination because of race, color, religion, sex, marital status, national origin or ancestry, age, or physical or mental handicap unrelated to ability, or an unfavorable discharge from military service; (IV) send to each labor organization or representative of workers with which it has or is bound by a collective bargaining or other agreement or understanding, a notice advising such labor organization or representative of the Vendor's obligations under the Illinois Human Rights Act and Department's Rules and Regulations for Public Contract; (V) submit reports as required by the Department's Rules and Regulations for Public Contracts, furnish all relevant information as may from time to time be requested by the Department or the contracting agency, and in all respects comply with the Illinois Human Rights Act and Department's Rules and Regulations for Public Contracts; (VI) permit access to all relevant

books, records, accounts and work sites by personnel of the contracting agency and Department for purposes of investigation to ascertain compliance with the Illinois Human Rights Act and Department's Rules and Regulations for Public Contracts; and (VII) include verbatim or by reference the provisions of this Equal Employment Opportunity Clause in every subcontract it awards under which any portion of this Agreement obligations are undertaken or assumed, so that such provisions will be binding upon such subcontractor.

In the same manner as the other provisions of this Agreement, the Bidder will be liable for compliance with applicable provisions of this clause by such subcontractors; and further it will promptly notify the contracting agency and the Department in the event any subcontractor fails or refuses to comply therewith. In addition, the Bidder will not utilize any subcontractor declared by the Illinois Human Rights Department to be ineligible for contracts or subcontracts with the State of Illinois or any of its political subdivisions or municipal corporations.

Subcontract" means any agreement, arrangement or understanding, written or otherwise, between the Bidder and any person under which any portion of the Bidder's obligations under one or more public contracts is performed, undertaken or assumed; the term "subcontract", however, shall not include any agreement, arrangement or understanding in which the parties stand in the relationship of an employer and an employee, or between a Bidder or other organization and its customers.

In the event of the Bidder's noncompliance with any provision of this Equal Employment Opportunity Clause, the Illinois Human Right Act, or the Rules and Regulations for Public Contracts of the Department of Human Rights the Bidder may be declared non-responsible and therefore ineligible for future contracts or subcontracts with the State of Illinois or any of its political subdivisions or municipal corporations, and this agreement may be canceled or avoided in whole or in part, and such other sanctions or penalties may be imposed or remedies involved as provided by statute or regulation.

6) PREVAILING WAGE COMPLIANCE: Yes [] No []

In the manner and to the extent required by law, this bid is subject to the Illinois Prevailing Wage Act and to all laws governing the payment of wages to laborers, workers and mechanics of a Bidder or any subcontractor of a Bidder bound to this agreement who is performing services covered by this contract. If awarded the Contract, per 820 ILCS 130 et seq. as amended, Bidder shall pay not less than the prevailing hourly rate of wages, the generally prevailing rate of hourly wages for legal holiday and overtime work, and the prevailing hourly rate for welfare and other benefits as determined by the Illinois Department of Labor or the Village and as set forth in the schedule of prevailing wages for this contract to all laborers, workers and mechanics performing work under this contract (available at <http://www.illinois.gov/idol/Laws-Rules/CONMED/Pages/Rates.aspx>).

The undersigned Bidder further stipulates and certifies that it has maintained a satisfactory record of Prevailing Wage Act compliance with no significant Prevailing Wage Act violations for the past three (3) years.

In accordance with Public Act 94-0515, the Bidder will submit to the Village certified payroll records (to include for every worker employed on the project the name, address, telephone number, social security number, job classification, hourly wages paid in each pay period, number of hours worked each day and starting and ending time of work each day) on a monthly basis, along with a statement affirming that such records are true and accurate, that the wages paid to each worker are not less than the required prevailing rate and that the Bidder is aware that knowingly filing false records is a Class B Misdemeanor.

7) PARTICIPATION IN APPRENTICESHIP AND TRAINING PROGRAM: Yes [] No []

Bidder participates in apprenticeship and training programs applicable to the work to be performed on the project, which are approved by and registered with the United States Department of Labor's Office of Apprenticeship.

Name of A&T Program: Laborers Local 1

Brief Description of Program: _____

8) TAX COMPLIANT: Yes [] No []

Bidder is current in the payment of any tax administered by the Illinois Department of Revenue, or if it is not: (a) it is contesting its liability for the tax or the amount of tax in accordance with procedures established by the appropriate Revenue Act; or (b) it has entered into an agreement with the Department of Revenue for payment of all taxes due and is currently in compliance with that agreement.

AUTHORIZATION & SIGNATURE:

I certify that I am authorized to execute this Affidavit of Compliance on behalf of the Bidder set forth on the Bidder Summary Sheet, that I have personal knowledge of all the information set forth herein and that all statements, representations, that the bid is genuine and not collusive, and information provided in or with this Affidavit are true and accurate.

The undersigned, having become familiar with the Project specified in this bid, proposes to provide and furnish all of the labor, materials, necessary tools, expendable equipment and all utility and transportation services necessary to perform and complete in a workmanlike manner all of the work required for the Project.

ACKNOWLEDGED AND AGREED TO:

Salvatore Guttadauro
Signature of Authorized Officer

Salvatore Guttadauro
Name of Authorized Officer

President
Title

9/8/16
Date

Subscribed and Sworn To
Before Me This 8 Day
of September, 2016

Katelin Miller
Notary Public Signature



NOTARY SEAL

INSURANCE REQUIREMENTS

Please submit a policy Specimen Certificate of Insurance showing bidder's current coverage's

WORKERS COMPENSATION & EMPLOYER LIABILITY

- \$500,000 – Each Accident
- \$500,000 – Policy Limit
- \$500,000 – Each Employee
- Waiver of Subrogation in favor of the Village of Orland Park

AUTOMOBILE LIABILITY

- \$1,000,000 – Combined Single Limit
- Additional Insured Endorsement in favor of the Village of Orland Park

GENERAL LIABILITY (Occurrence basis)

- \$1,000,000 – Each Occurrence
- \$2,000,000 – General Aggregate Limit
- \$1,000,000 – Personal & Advertising Injury
- \$2,000,000 – Products/Completed Operations Aggregate
- Additional Insured Endorsement & Waiver of Subrogation in favor of the Village of Orland Park

EXCESS LIABILITY (Umbrella-Follow Form Policy)

- \$2,000,000 – Each Occurrence
- \$2,000,000 – Aggregate
- EXCESS MUST COVER:** General Liability, Automobile Liability, Workers Compensation

Any insurance policies providing the coverages required of the successful Bidder, shall be specifically endorsed to identify "The Village of Orland Park, and their respective officers, trustees, directors, employees and agents as Additional Insureds on a primary/non-contributory basis with respect to all claims arising out of operations by or on behalf of the named insured." If the named insureds have other applicable insurance coverage, that coverage shall be deemed to be on an excess or contingent basis. The policies shall also contain a Waiver of Subrogation in favor of the Additional Insureds in regards to General Liability and Workers Compensation coverage's. The certificate of insurance shall also state this information on its face. Any insurance company providing coverage must hold an A VII rating according to Best's Key Rating Guide. Permitting the successful Bidder, or any subcontractor, to proceed with any work prior to our receipt of the foregoing certificate and endorsement however, shall not be a waiver of the successful Bidder's obligation to provide all of the above insurance.

Bidders agree that if they are the successful Bidder, within ten (10) days after the date of notice of the award of the contract and prior to the commencement of any work, you will furnish evidence of Insurance coverage providing for at minimum the coverages and limits described above directly to the Village of Orland Park, Denise Domalewski, Contract Administrator, 14700 S. Ravinia Avenue, Orland Park, IL 60462. Failure to provide this evidence in the time frame specified and prior to beginning of work may result in the termination of the Village's relationship with the selected bidder and the bid will be awarded to the next lowest bidder or result in creation of a new bid.

ACCEPTED & AGREED THIS 8 DAY OF September, 2016



Signature
Salvatore Guttadauro - President
 Printed Name & Title

Authorized to execute agreements for:

Crossroad Construction, inc.
 Name of Company

REFERENCES

Provide three (3) references for which your organization has performed similar work.

Bidder's Name: Crossroad Construction, Inc.
(Enter Name of Business Organization)

- 1. ORGANIZATION Bolingbrook Park District
 ADDRESS 201 Recreation Drive, Bolingbrook, IL 60440
 PHONE NUMBER 630-783-6563
 CONTACT PERSON Jim Patula
 YEAR OF PROJECT 2015

- 2. ORGANIZATION Elk Grove Park District
 ADDRESS 499 Biesterfeld Road, Elk Grove, IL 60007
 PHONE NUMBER 847-228-7911
 CONTACT PERSON Ben Curcio
 YEAR OF PROJECT 2016

- 3. ORGANIZATION Morton Grove Park District
 ADDRESS 6834 Dempster Street, Morton Grove, IL 60053
 PHONE NUMBER 847-965-0065
 CONTACT PERSON Greg Jayne
 YEAR OF PROJECT 2016

Village of Orland Park Bid Tabulation

Bid Number: 16-028
Bid Issued: August 23, 2016
Bid Opening: September 8, 2016



Project Title: CPAC Inlet Replacement
Department: Parks
Addendum No. x - n/a

Bidder	<u>Grand Total Bid Price</u> <u>Per Unit Price</u>	Contact Person & Location
Crossroad Construction, Inc.	\$31,480 \$450/unit	Salvatore Gruttadauro 1N725 Swift Road Lombard, IL 60148 P: 630-847-9400/F: 630-627-9601 Email: Tory.crossroad@gmail.com

Bids are subject to review for completeness, accuracy and compliance with all terms and conditions of the bid specifications.

Prepared by: Denise Domalewski, Contract Administrator - Village of Orland Park

Village of Orland Park Bid Responsiveness Check

Bid Number: 16-028

Project Title: CPAC Inlet Replacement

Bid Requirement	Crossroad Construction Inc.							
Submitted three (3) sealed hardcopies of the bid	✓							
Submitted a completed Bidder Summary Sheet	✓							
Submitted a completed Affidavit of Compliance	✓							
Submitted three (3) references	✓							
Submitted signed Insurance Requirements form	✓							
Unit Price	\$450							
Proposed amount	\$31,480.00							

**A check mark in the box indicates inclusion of the required form with the proposal package. A "V#" indicates a variance that will be explained below.*

Prepared by: Denise Domalewski, Contract Administrator - Village of Orland Park

DATE: September 19,
2016

REQUEST FOR ACTION REPORT

File Number: **2016-0652**
Orig. Department: **Parks Department**
File Name: **Laurel Hills Basketball/Tennis Court Repairs**

BACKGROUND:

The combined basketball tennis court area at Laurel Hills Park has presented with several large cracks and movement of the paved surface. Staff reached out to US Tennis Court Construction Company for a proposal to repair the paved surfaces. The repairs should carry the Village for a few years so that budgeting can be put in place to repave the court areas in the future.

Costs to clean out and install the court patch binder in the cracked areas and leveling low "bird bath" areas, followed by application of the resurfacer and striping are \$8,750.00. US Tennis has worked with the Village on several other projects that have been very successful.

BUDGET IMPACT:

Funds for repair work will come from Parks account 283-4003-443500

REQUESTED ACTION:

I move to recommend to the Village Board to accept the quote from US Tennis Construction Company to repair the courts surfaces at Laurel Hills Park at a cost not to exceed \$8,750.00.

U.S. Tennis Court Construction Company
 204 Industrial Dr.
 Lockport, IL 60441
 Phone # (815)588-3700
 Fax # (815)588-3707
 ustenniscourt@gmail.com
 www.ustennisc.com



Quote

Date	Quote #
4/28/2016	2016.136

Customer

Village of Orland Park
 14700 South Ravinia Avenue
 Orland Park, IL 60462
 Matt Creed
 mcreed@orland-parks.il.us
 Phone:
 Fax:

Project

Laurel Hill Park 2 basketball with tennis

Item	Description	Amount
Color coat system	1. Pressure wash stained areas in preparation for color surfacing 2. Rout, clean, and fill cracks with court patch binder 3. Level "bird baths" to reduce duration of standing water 4. sand an pre-coat all patches 5. Apply 1 coat of acrylic resurfacer 6. Apply 2 coats of color 7. apply line striping **Cracks will form where structural cracks have been filled in the fall of the same year if ARMOR is not included. See alternates	8,750.00
Alternates	#1.)Furnish and install Armor Crack Repair over approximately 350 Linear feet of structural crack * Include 2 year warranty on cracks that have been repaired with armor. Armor does not prohibit or cause cracking outside the ARMOR patched area. Cracks forming outside the repaired area are not covered by the warranty.The product is intended to Release from the surface to allow the asphalt to move beneath it. Also, because the color surface is not as flexible as the release tape, the color may fracture over the area of the release tape after a few years. These are not considered a failures. ADD: \$6,300.00 to above quoted amount to accept alt. #1. #2) Break down heaved footings on south fence and patch with hot asphalt. Adjust fence and rails to proper height. ADD: \$2,300.00 #3) Scrap prep and paint all fence rails and poles. ADD: \$ 2,900.00	
Terms:	Based on Completion	
Total		\$8,750.00

**When temperatures drop below 40°F, hairline cracks will return where structural cracks have been filled.*

If listed above, please list accepted alternates by number before returning: _____

All work is covered by a one year warranty. All work is to be completed in a workman like manner in accordance with standard practices. Any alteration or deviation from the above outlined description involving extra cost will be executed upon written order and will become an extra charge over and above this estimate. Our employees are completely covered by workmen's compensation insurance. Certified payroll is available upon request.

*****ACCEPTANCE OF PROPOSAL*****

If the quotation is acceptable, please either submit a written purchase order, subcontract agreement, or sign and date this form. The signing of this form is an acknowledgement that the above scope of work, pricing, and conditions are satisfactory and are hereby accepted. And that U.S. Tennis Court Construction Co. is authorized to complete the work as specified. Quote valid for 90 days.

Prepared By:

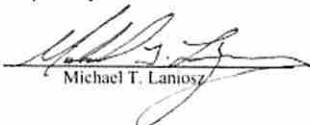
 Michael T. Lamosz

Upon Acceptance Sign, _____ Date: _____

Name & Title _____

DATE: September 19,
2016

REQUEST FOR ACTION REPORT

File Number: **2016-0653**
Orig. Department: **Parks Department**
File Name: **Greystone Ridge Park Identification Sign**

BACKGROUND:

The Parks Department will be taking possession of Greystone Ridge Park this fall. The park site was completely built by the subdivision developer (Beechen & Dill). The site includes playground equipment as well as a pavilion area for the residents. While the developer has provided most of the amenities, the Village needs to purchase a Park identification sign.

The Village has recently implemented a change in branding, and the Parks department is currently having the new logo (symbol) incorporated into a sign at Dogwood Park which is under construction. The redesign is costing considerably less than the original design.

Attached is a rough drawing from Parkreation of the proposed signage to be installed at Greystone Ridge Park.

The Village has worked with Parkreation for years and they are one of our primary playground vendors.

Funds for this project were not specifically budgeted, however funding can be acquired through several Parks accounts. The cost for the engineering, construction and delivery of the sign is \$8,816.00.

BUDGET IMPACT:

Funds are budgeted in accounts 283-4003-461500 and 283-4003-461600

REQUESTED ACTION:

I move to recommend to the Village Board to approve the purchase of the Park identification sign for Greystone Ridge Park from Parkreation at a cost not to exceed \$8,816.00.

PARKREATION, INC
27 East Palatine Road, Prospect Heights, IL 60070

August 25, 2016

Quotation Number: P082516A

Village of Orland Park
 14700 Ravinia Drive
 Orland Park IL 60462

Project Name: Grey Stone Entrance arch

Quoted By: Paul Gozder 815-735-1497

<u>QTY</u>	<u>Product #</u>	<u>Description</u>	<u>All pricing is valid for 30 days</u>	<u>Unit Price</u>	<u>Total Price</u>
01	EA10X1-10	Custom entrance arch for Grey Stone Park E Coat / Powder Coat color / final gloss finish Surface mount with base covers Illinois stamped engineered drawings Shipping to Orland Park, IL Total			\$ 7,816.00
		Frame Color. Logo Color:		add	\$ 250.00
					<u>\$ 750.00</u>
					\$ 8,816.00

- Terms:
1. *I/We understand that all accounts are payable to Parkreation, Inc. according to the terms of their invoice, and if not paid on or before said date, are then delinquent. I/We agree to pay any and all service charges added each month to past due invoices. Terms are Net 30 days upon delivery with approved credit. All charges are due and payable in full at Parkreation, Inc., 27 E. Palatine Rd., Prospect Heights, IL 60070 unless notified in writing to the contrary. To the extent the terms and conditions of any purchase order/contract and/or any purchase order/contract confirmations are inconsistent with the terms and conditions of this signed quote, the terms and conditions of this signed quote shall prevail.
 2. All pricing is valid for 30 days from the date above.
 3. The above pricing (if more than one item) is based upon a package purchase. Any adjustments may be subject to a price revision.
 4. Customer is responsible for the off-loading of the equipment and an accurate inventory should be taken at the time and all missing or damaged parts should be noted to the Driver. You have 60 days to report any missing or damaged parts to your sales representative. Truck Driver will not unload equipment.
 5. Nontaxable entities are required to provide copy of tax exempt certificate or be taxed upon invoice.
 6. Installation not included unless specifically quoted

Date _____ Purchaser's Signature _____ Purchaser's Title _____

Email Address _____ Special Instructions _____

Ship to address _____

Park Site Address _____

IllinoisOffice@Parkreation.com - 27 East Palatine Road, Prospect Heights, IL 60070 - Phone 847-419-7744, Fax 847-419-7747

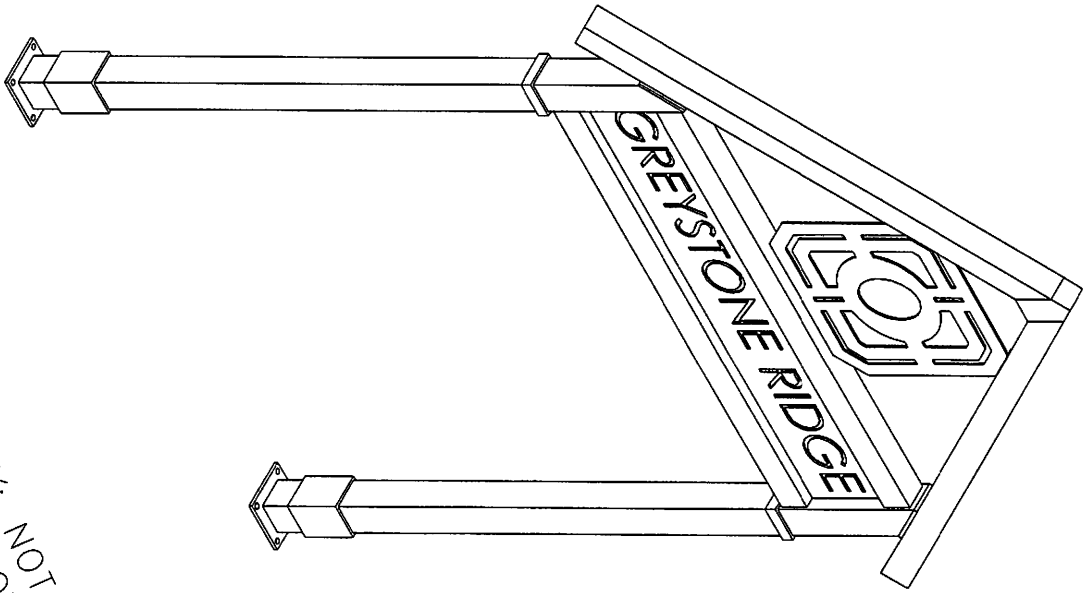
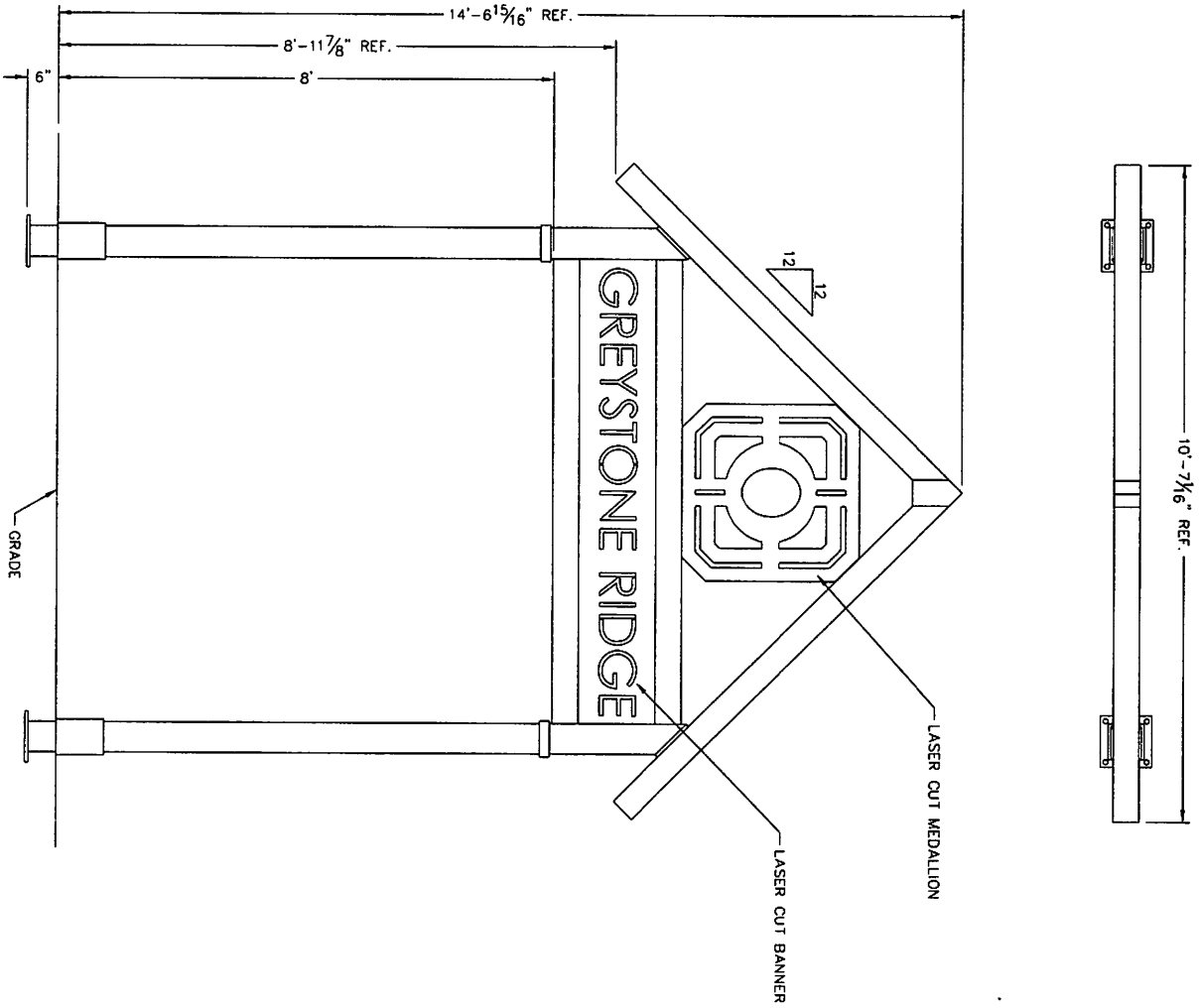

PRELIMINARY: NOT FOR
CONSTRUCTION

SHEET
1.0

DRAWN BY:	ACP
DATE:	8/16/2016
JOB NO.:	STANDARD
REVISION:	B
BUILDING TYPE:	EA10-10-P12
PROJECT NAME:	

Elevation

ICON
 Shelter Systems Inc
 DISTINCTIVE STEEL SHEETPIES
 CORRUGATED PANEL FABRICATION
 SYSTEMS, INC.
 1485 LINCOLN AVE.
 HOLLAND, MI 49423
 616.396.0919
 800.748.0945
 616.396.0941 FX

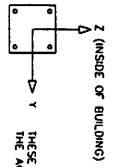

THESE FOUNDATION LOADS ARE FOR ESTIMATING PURPOSES ONLY. THE ACTUAL LOADS WILL BE DETERMINED IN THE FINAL STRUCTURING.

LOAD COMBINATION	FOUNDATION LOADS			
	AXIAL (F _x)	SHEAR (F _y)	SHEAR (F _z)	MOMENT (M _x)
DL	4.02	0.00	0.16	-5.62
SL	2.66	0.00	0.23	-8.90
W-UPLIFT	-4.25	-0.35	-0.50	5.63
W-FY	-2.70	-0.59	-0.17	-5.49
W-FZ	-2.95	-0.54	-0.63	23.63
E-FY	0.00	-0.80	0.00	-7.64
E-FZ	-0.61	0.00	-1.02	43.37

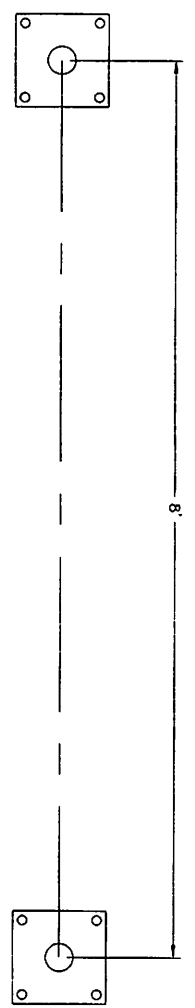

NOTES:

- TABLE SHOWS UNFACTORED SERVICE LOADS
- A FOUNDATION DESIGN HAS NOT BEEN PERFORMED BY ICON SHELTER SYSTEMS INC.
- A FOUNDATION DESIGN SHALL BE PERFORMED BY THE ENGINEER RESPONSIBLE FOR THE DESIGN OF THE STRUCTURE.
- THE STRUCTURE HAS BEEN ENGINEERED AS AN OPEN STRUCTURE.
- CONSULT ICON SHELTER SYSTEMS INC. IF THE STRUCTURE IS TO BE ENCLOSED.
- COORDINATES ARE LOCAL TO THE COLUMN.

DEFINITIONS:

- DL = SERVICE LEVEL DEAD LOAD REACTION WITH THE GREATEST AXIAL LOAD
- SL = SERVICE LEVEL SNOW LOAD REACTION WITH THE GREATEST AXIAL LOAD
- W-UPLIFT = SERVICE LEVEL WIND UPLIFT LOAD REACTION WITH THE GREATEST UPLIFT LOAD
- W-FY = SERVICE LEVEL WIND LOAD REACTION WITH THE GREATEST MAGNITUDE OF SHEAR IN THE LOCAL Y DIRECTION
- W-FZ = SERVICE LEVEL WIND LOAD REACTION WITH THE GREATEST MAGNITUDE OF SHEAR IN THE LOCAL Z DIRECTION
- E-FY = SERVICE LEVEL SEISMIC LOAD REACTION WITH THE GREATEST MAGNITUDE OF SHEAR IN THE LOCAL Y DIRECTION
- E-FZ = SERVICE LEVEL SEISMIC LOAD REACTION WITH THE GREATEST MAGNITUDE OF SHEAR IN THE LOCAL Z DIRECTION

PRELIMINARY: NOT FOR CONSTRUCTION

ALL STRUCTURAL COMPONENTS WILL BE:
 TUBE: ASTM A500 GRADE B
 PLATE: ASTM A36
 BOLTS: ASTM A325
 NUTS: ASTM A563
 WELDING: GMAW

NOTE:
 COLUMN SIZE: HSS 6x6x3/16

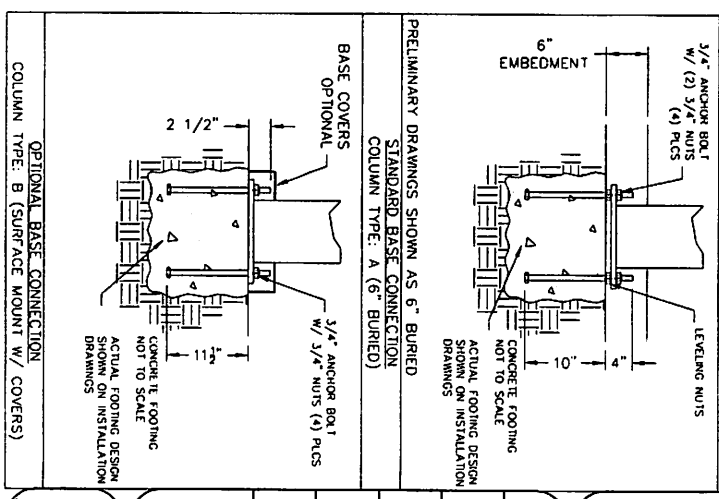

ICON
 Shelter Systems Inc.
 DISTRICT AREA SHELTERS
 11111 W. 10TH AVE.
 DENVER, CO 80231
 303.754.0944

11111 W. 10TH AVE.
 DENVER, CO 80231
 303.754.0944

DRAWN BY: ACP
 DATE: 8/16/2016
 JOB NO.: STANDARD
 REVISION: B

BUILDING TYPE: EA10-10-P12
 PROJECT NAME:

ANCHOR BOLT LAYOUT

SHEET
 20

Anchor Bolt Layout

20

DATE: September 19,
2016

REQUEST FOR ACTION REPORT

File Number: **2016-0644**
Orig. Department: **Recreation Department**
File Name: **2016 Turkey Trot Race Shirt Purchase Approval**

BACKGROUND:

The 28th Annual Turkey Trot will be held on Thursday, November 24, 2016. This event has grown over the last few years to include 800 participants in this family friendly, traditional 2.5 mile cross country race. Staff is requesting approval to purchase long sleeve race shirts for the 2016 Turkey Trot. The cost of the race shirts is included in the registration fee.

Staff has received four quotes for Expert Brand AJ901 100% microfiber long sleeve tech race shirts. (See attached) Staff is recommending the purchase be made through Marathon Sportswear, Inc. of Blue Island, Illinois, which is the lowest quote received in the amount of \$6,411.60 plus shipping.

BUDGET IMPACT:

This item has been budgeted in account 283-4002-490410.

REQUESTED ACTION:

I move to recommend to the Village Board to approve the purchase of the 2016 Turkey Trot race shirts from Marathon Sportswear, Inc. of Blue Island, Illinois in the amount of \$6,411.60 plus shipping.

2016 TURKEY TROT T-SHIRT QUOTES

Expert AJ901	Youth Shirts	S - XL	XXL	XXXL	Screen Charge	Shipping	Total
Estimated Quantity	50	930	60	8	4	na	1048

Marathon Sportswear, Inc.	\$5.95	\$5.95	\$6.95	\$7.95	\$25.00	TBD	
Estimated Cost AJ901	\$297.50	\$5,533.50	\$417.00	\$63.60	\$100.00	\$0.00	\$6,411.60

Green Light Apparel	\$6.50	\$6.50	\$6.50	\$6.50	\$0.00	TBD	
Estimated Cost (Marathon T)	\$325.00	\$6,045.00	\$390.00	\$52.00	\$0.00	\$0.00	\$6,812.00

Champion Screen Printing & Embroidery	\$6.86	\$6.86	\$9.23	\$9.23	\$0.00	\$0.00	
Estimated Cost	\$343.00	\$6,379.80	\$553.80	\$73.84	\$0.00	\$0.00	\$7,350.44

New Life Screen Printing & Embroidery	\$9.50	\$9.50	\$11.50	\$12.50	\$0.00	\$0.00	
Estimated Cost	\$475.00	\$8,835.00	\$690.00	\$100.00	\$0.00	\$0.00	\$10,100.00