



VILLAGE OF ORLAND PARK

14700 Ravinia Avenue
Orland Park, IL 60462
www.orland-park.il.us

Meeting Agenda

Board of Trustees

Village President Daniel J. McLaughlin

Village Clerk John C. Mehalek

*Trustees, Kathleen M. Fenton, James V. Dodge, Jr., Patricia Gira,
Carole Griffin Ruzich, Daniel T. Calandriello, and Michael F. Carroll*

Tuesday, July 5, 2016

7:00 PM

Village Hall

1. CALL TO ORDER/ROLL CALL

2. PLEDGE OF ALLEGIANCE

3. VILLAGE CLERK'S OFFICE

2016-0496 Approval of the June 20, 2016 Regular Meeting Minutes

Attachments: [Draft Minutes](#)

2016-0476 Saint Michael's Parish - Raffle License

Attachments: [Raffle Application](#)

2016-0481 In Search of a Cure - Raffle License

Attachments: [Raffle Application](#)

2016-0475 Catholic Charities - Raffle License

Attachments: [Raffle Application](#)

4. PROCLAMATIONS/APPOINTMENTS/PRESENTATIONS

2016-0473 Community Pride Award - Grace Rost

2016-0474 Community Pride Award - Victoria Kappel

5. PRE-SCHEDULED CITIZENS & VISITORS

6. CONSENT AGENDA

A. **2016-0488** Payroll - Approval

Attachments: [Payroll 7-1-16](#)

- B. [2016-0489](#) Accounts Payable - Approval
- Attachments:** [AP Listing](#)
- C. [2016-0444](#) Disposal of Certain Seized Vehicles at Public Auction - Ordinance
- Attachments:** [Exhibit A](#)
[Ordinance](#)
- D. [2016-0304](#) Southside Chicago Hitmen
- Attachments:** [Floor Plan](#)
[Plat](#)
[Special Use Standards](#)
- E. [2016-0313](#) Team Rockhouse - Motor Vehicle Services
- Attachments:** [Building Description](#)
[Scope of Work](#)
[Aerial](#)
[Special Use Standards](#)
- F. [2016-0344](#) Cosmetic Enhancement Clinic and Academy
- Attachments:** [Aerial](#)
[Special Use Standards](#)
- G. [2016-0456](#) 2016 Village Code Amendments - Amusement Device Licenses
-Title 7-6-2 - Ordinance
- Attachments:** [Ordinance](#)
- H. [2016-0391](#) Sandburg High School Monument Sign
- Attachments:** [Carl Sandburg Sign Rendering](#)
[Carl Sandburg Bid Summary only](#)
[Carl Sandburg Signage Plans](#)
[Carl Sandburg IGA](#)
- I. [2016-0455](#) Amusement Device Operators Licenses - Removal & Addition
- Attachments:** [Babies R Us](#)
[Dennys](#)
[Jewel - Wolf Rd](#)
[Toys R Us](#)
[Twin Peaks](#)
[Fattie's Pub](#)
[Gizmo's](#)

7. HEARINGS 7:00 P.M.

8. PUBLIC SAFETY

9. TECHNOLOGY, INNOVATION AND PERFORMANCE IMPROVEMENT

10. PUBLIC WORKS

[2016-0495](#) Orlan Brook Drive Culvert Replacement - Bid and Construction Engineering Services

Attachments: [Baxter & Woodman Proposal](#)
[Bid Tabulation](#)
[Hasse Bid](#)

11. DEVELOPMENT SERVICES, PLANNING AND ENGINEERING

12. PARKS AND RECREATION

13. FINANCE

14. MAYOR'S REPORT

15. VILLAGE MANAGER'S REPORT

[2016-0467](#) Amend Village Policy - Resolution

Attachments: [Resolution](#)

[2016-0502](#) Refuse, Recycling and Yard Waste Collection and Disposal Agreement - First Amendment

Attachments: [First Amendment to Agreement](#)

16. NON-SCHEDULED CITIZENS & VISITORS

17. BOARD COMMENTS

18. EXECUTIVE SESSION

A. Approval of Minutes

B. The Appointment, Employment, Compensation, Discipline, Performances or Dismissal of Specific Village Employees

C. The Purchase or Lease of Real Property for the Use of The Village

D. Setting a Price for Sale or Lease of Village Property

E. Pending Litigation Against, Affecting or on Behalf of The Village or When Found by The Board that Such Action is Probable or Imminent

19. RECONVENE BOARD MEETING

Report on Executive Session and Action as a Result of, if any.

20. ADJOURNMENT

DATE: July 5, 2016

REQUEST FOR ACTION REPORT

File Number:	2016-0496
Orig. Department:	Village Clerk
File Name:	Approval of the June 20, 2016 Regular Meeting Minutes

BACKGROUND:

BUDGET IMPACT:

REQUESTED ACTION:

I move to approve the minutes of the Board of Trustees Meeting of June 20, 2016.

VILLAGE OF ORLAND PARK

14700 Ravinia Avenue
Orland Park, IL 60462
www.orland-park.il.us



Meeting Minutes

Monday, June 20, 2016

7:00 PM

Village Hall

Board of Trustees

Village President Daniel J. McLaughlin

Village Clerk John C. Mehalek

*Trustees, Kathleen M. Fenton, James V. Dodge, Jr., Patricia Gira,
Carole Griffin Ruzich, Daniel T. Calandriello, and Michael F. Carroll*

CALL TO ORDER/ROLL CALL

The meeting was called to order at 7:00 PM.

Present: 6 - Trustee Fenton, Trustee Gira, Trustee Griffin Ruzich, Trustee Calandriello, Trustee Carroll and President McLaughlin

Absent: 1 - Trustee Dodge

VILLAGE CLERK'S OFFICE

2016-0453 Approval of the June 6, 2016 Regular Meeting Minutes

The Minutes of the Regular Meeting of June 6, 2016, were previously distributed to the members of the Board of Trustees. President McLaughlin asked if there were any corrections or additions to be made to said Minutes. There being no corrections or additions,

I move to approve the minutes of the Board of Trustees Meeting of June 6, 2016.

A motion was made by Trustee Fenton, seconded by Trustee Calandriello, that this matter be APPROVED. The motion carried by the following vote:

Aye: 6 - Trustee Fenton, Trustee Gira, Trustee Griffin Ruzich, Trustee Calandriello, Trustee Carroll, and President McLaughlin

Nay: 0

Absent: 1 - Trustee Dodge

2016-0388 The Sepsis Alliance of Illinois - Raffle License

The Sepsis Alliance of Illinois is requesting a license to sell raffle tickets at their Annual Illinois Sepsis Challenge 5K event on Sunday, July 30, 2016 at Centennial Park. All profits will go to the distribution of educational materials to communities for increase awareness of sepsis.

I move to approve issuing a raffle license to The Sepsis Alliance of Illinois to sell raffle tickets at their annual Illinois Sepsis Challenge 5K event on Sunday, July 30, 2016 at Centennial Park.

A motion was made by Trustee Gira, seconded by Trustee Carroll, that this matter be APPROVED. The motion carried by the following vote:

Aye: 6 - Trustee Fenton, Trustee Gira, Trustee Griffin Ruzich, Trustee Calandriello, Trustee Carroll, and President McLaughlin

Nay: 0

Absent: 1 - Trustee Dodge

2016-0441 Orland Township Food & Pet Pantry - Raffle License

The Orland Township Food & Pet Pantry is requesting a license to conduct a raffle

at their Pet Palooza on Saturday, June 25, 2016 from 12:00 PM to 3:00 PM at The Orland Township, 14807 South Ravinia Avenue. All funds raised will go to the Orland Township Food & Pet Pantry.

I move to approve issuing a raffle license to the Orland Township Food & Pet Pantry to conduct a raffle at their Pet Palooza event on Saturday, June 25, 2016 at The Orland Township.

A motion was made by Trustee Carroll, seconded by Trustee Calandriello, that this matter be APPROVED. The motion carried by the following vote:

Aye: 6 - Trustee Fenton, Trustee Gira, Trustee Griffin Ruzich, Trustee Calandriello, Trustee Carroll, and President McLaughlin

Nay: 0

Absent: 1 - Trustee Dodge

2016-0466 The American Legion Orland Memorial Post #111 - Raffle License

The American Legion Orland Memorial Post #111 is requesting a license to sell raffle tickets beginning July 1st through September 27, 2016. They are also requesting to sell tickets at their booth during the Taste of Orland event. The raffle drawing will take place at 8:00 PM on September 28, 2016 at the George Brown Veterans Center.

I move to approve issuing a raffle license to The American Legion Orland Memorial Post #111 to sell raffle tickets beginning July 1, 2016 through September 27, 2016;

And

Approve The American Legion Orland Memorial Post #111 to sell raffle tickets at their booth during the Taste of Orland (August 5th through August 7, 2016).

A motion was made by Trustee Fenton, seconded by Trustee Gira, that this matter be APPROVED. The motion carried by the following vote:

Aye: 6 - Trustee Fenton, Trustee Gira, Trustee Griffin Ruzich, Trustee Calandriello, Trustee Carroll, and President McLaughlin

Nay: 0

Absent: 1 - Trustee Dodge

PROCLAMATIONS/APPOINTMENTS/PRESENTATIONS

2016-0425 Veterans Commission - Appointment

President McLaughlin appointed Robert Estand as a member of the Veterans Commission.

I move to advise and consent to the appointment by Mayor McLaughlin of Robert Estand as a member of the Veterans Commission.

A motion was made by Trustee Carroll, seconded by Trustee Fenton, that this matter be APPROVED. The motion carried by the following vote:

Aye: 6 - Trustee Fenton, Trustee Gira, Trustee Griffin Ruzich, Trustee Calandriello, Trustee Carroll, and President McLaughlin

Nay: 0

Absent: 1 - Trustee Dodge

2016-0423 Veterans Commission - Appointment

President McLaughlin appointed Darryl Wertheim to the Veterans Commission.

I move to advise and consent to the appointment by Mayor McLaughlin of Darryl Wertheim to the Veterans Commission.

A motion was made by Trustee Carroll, seconded by Trustee Fenton, that this matter be APPROVED. The motion carried by the following vote:

Aye: 6 - Trustee Fenton, Trustee Gira, Trustee Griffin Ruzich, Trustee Calandriello, Trustee Carroll, and President McLaughlin

Nay: 0

Absent: 1 - Trustee Dodge

2016-0431 Community Pride Award - Evita Griskenas

President McLaughlin recognized Sandburg freshman and honors student Evita Griskenas for winning the All-Around Senior National Qualifier at the Olympic Training Center in Lake Placid, New York in May. Evita is a Senior National Team Member who won Silver in ribbon apparatus in Providence, R.I. and Bronze medal in Hoops. She is the 2015 Junior All Around U.S. National Champion in rhythmic gymnastics.

This was a presentation, NO ACTION was required.

2016-0424 Community Pride Award - Elise Blinn

President McLaughlin presented a Community Pride Award to Century Junior High student Elise Blinn in recognition of her writing and illustrating her first book, Jewish Jammer, The Story of a Jewish Pilot in Desert Storm.

This was a presentation, NO ACTION was required.

CONSENT AGENDA

Passed the Consent Agenda

A motion was made by Trustee Griffin Ruzich, seconded by Trustee Gira, to PASS THE CONSENT AGENDA, including all the following items marked as having been adopted on the Consent Agenda. The motion carried by the following vote:

Aye: 6 - Trustee Fenton, Trustee Gira, Trustee Griffin Ruzich, Trustee Calandriello, Trustee Carroll, and President McLaughlin

Nay: 0

Absent: 1 - Trustee Dodge

2016-0434 Payroll - Approval

The lists of Payroll having been submitted to the Board of Trustees for approval and the lists having been determined by the Board of Trustees to be in order and having been approved by the various Department Heads,

I move to approve the Bi-Weekly Payroll for June 3, 2016 in the amount of \$1,052,554.89 and the Bi-Weekly Payroll for June 17, 2016 in the amount of \$1,107,772.55.

This matter was APPROVED on the Consent Agenda.

2016-0435 Accounts Payable - Approval

The lists of Accounts Payable having been submitted to the Board of Trustees for approval and the lists having been determined by the Board of Trustees to be in order and having been approved by the various Department Heads,

I move to approve the Accounts Payable from June 7, 2016 through June 20, 2016 in the amount of \$2,943,500.79.

This matter was APPROVED on the Consent Agenda.

2016-0280 Collections - Parking & Municipal Violation Tickets - Approval

In 2011, the Village entered into a five (5) year agreement with Municipal Collections of America (MCOA) for collection of outstanding parking and municipal violations. This agreement expires June 30, 2016. MCOA has provided exceptional service and Staff recommends that the Village Board authorize extending the term of this agreement an additional five (5) years.

Since 2011 MCOA has assisted the Village with collecting approximately \$110,000 in outstanding ordinance violation fines and \$992,000 in outstanding parking violation fines. For each dollar collected, 65% was remitted to the Village and recorded as revenue and 35% was retained by MCOA. Per a Board

approved Ordinance, effective January 1, 2016, the cost of collections (including debt recovery fees) is added to the original fine amount, enabling the Village to collect 100% of the outstanding fine amount. MCOA also provided assistance with the set up and implementation of the Village's participation in the State of Illinois Debt Recovery Program.

I move to approve extending the agreement with Municipal Collections of America, Inc. for the collection of past due parking and municipal violation tickets for one (1) year, with the option to renew for four (4) additional one (1) year terms.

This matter was APPROVED on the Consent Agenda.

2016-0372 2015 Annual Treasurer's Report - Acknowledgement

The 2015 Annual Treasurer's Report must be filed with the Village Clerk as required by statute on or before June 30, 2016. A copy of this report is attached in Legistar. The statutory requirements regarding the publication and filing of this report with the Treasurer and Clerk of Cook and Will Counties will also be completed.

I move to acknowledge the filing of the Annual Treasurer's Report.

This matter was APPROVED on the Consent Agenda.

2016-0399 Road Program Sidewalk Gap Funding Addition - Approval

To accommodate seamless pedestrian access within Village boundaries, the Village is continuing its initiative to eliminate gaps that exist between sidewalks and pedestrian paths routes. This year, the Public Works Department has identified a pedestrian path gap that exists on the west side of 88th Avenue along the east edge of Schussler Park between Golfview Drive and 144th Street.

Funding for sidewalk gap work is annually appropriated in the capital budget. There is \$25,000 allocated in the FY16 capital budget for the construction of sidewalk and pedestrian paths. To take advantage of the bid cost and known unit pricing provided by the Road Improvement Program contractor, it is staff's recommendation that this work also be completed through that program.

There is an opportunity to take advantage of known competitive unit pricing in our Road Improvement Program by utilizing our contractor, D Construction Company of Coal City, Illinois, to complete this work. Staff recommends utilizing the budgeted funds in the sidewalk gap account to complete the 88th Avenue gap project and an additional project on 183rd Street. Funds remaining after the completion of this work will be used to complete additional sidewalk gaps that may be identified prior to the end of the 2016 construction season.

I move to approve adding funding to the 2016 Road Improvement Program contract with D-Construction, of Coal City, IL for the installation of sidewalk and pedestrian path gaps at the current contract unit prices in an amount not to exceed the Board approved budget.

This matter was APPROVED on the Consent Agenda.

2016-0392 Maycliff Subdivision Storm Water Improvement Easements - Ordinance

As part of the Maycliff Subdivision Storm Water Improvement Project, numerous easements are needed for the installation of the proposed piping to address backyard drainage issues. Due to the use of directional boring pipe installation techniques, no temporary easements are required. Two additional permanent easements have been finalized with the property owner listed below. Acquisition of the easements requires an ordinance to be enacted and is detailed in the attached documents in Legistar. The total costs for the easement is \$6,600.00.

- a) 8601 W. 143rd Place (Westphal)
- b) 8557 W. 143rd Place (Bradshaw)

I move to pass Ordinance Number 5104, entitled: (ORDINANCE AUTHORIZING ACCEPTANCE AND EXECUTION OF PUBLIC UTILITY AND DRAINAGE EASEMENTS AND PAYMENT OF COMPENSATION THEREFOR (MAYCLIFF STAGE 1 STORMWATER PROJECT))

This matter was PASSED on the Consent Agenda.

2016-0396 Kristo Lane and Dorstep Lane/81st Avenue Road Resurfacing - Proposal

Pavement resurfacing for Kristo Lane was planned and funded as a component of the Kristo Lane Storm Water Improvement GMP Project. Kristo Lane's resurfacing was funded at \$50,000 from the 2016 Road Program budget. During the beginning of the storm sewer project, it became apparent that the adjacent Dorstep Lane/81st Avenue, initially constructed at the same time as Kristo Lane, is in equally poor condition. With funding currently available, it would be ideal to resurface both streets under the same project.

The formal proposal from Burke LLC, including the expanded scope (resurfacing of both Kristo Lane and Dorstep Lane/81st Avenue) totaled \$163,311.00. To gauge whether or not this price was competitive, staff discussed completing this project under the 2016 Road Program. Staff solicited prices from this year's Road Program contractor, D-Construction, Inc. of Coal City, Illinois. D-Construction has agreed to complete this work using the 2016 Road Program contracted unit pricing. The estimated cost of this project using current unit pricing is \$75,338.38. The resurfacing of Kristo Lane and Dorstep Lane/81st Avenue project could be completed for a considerable savings by utilizing the 2016 Road Program pricing. To account for any unforeseen issues, staff is requesting that a \$10,000 contingency be added to the cost.

I move to approve adding Kristo Lane and Dorstep Lane/81st Avenue to the 2016 Road Improvement Program at a cost not to exceed \$85,338.38, which includes a \$10,000 contingency.

This matter was APPROVED on the Consent Agenda.

2016-0393 One (1) Ford AWD Utility Police Interceptor - Bid Award

The 2016 Fiscal Year Budget includes the purchase of one (1) replacement unmarked vehicle for the Police Department. Legal notice for the one (1) Ford AWD Utility Police Interceptor was placed in the Southtown Star newspaper on April 20, 2016. Sealed bids were opened by the Village Clerk's office on Wednesday, May 04, 2016.

Utilizing the Village's Local Vendor Purchasing Policy, it is staff's recommendation that the bid be awarded to Joe Rizza Ford of Orland Park in the amount of \$28,692.00. Rizza can deliver the Ford AWD Utility Police Interceptor within 60 days after receipt of the order. Rizza is within 2% of the lowest bidder, Terry's Ford of Peotone, Illinois (\$28,567.00).

I move to approve to utilize the Local Vendor Purchasing Policy and accept the bid for one (1) Ford AWD Utility Police Interceptor from Joe Rizza Ford of Orland Park, Illinois in an amount not to exceed \$28,692.00.

This matter was APPROVED on the Consent Agenda.

2016-0360 Village Code Building Code Amendments - Title 5, Chapter 1 - Ordinance

The Village of Orland Park currently uses the 2012 edition, of the "International Building Code" (IBC/2012) with Village amendments as the basis for its new construction regulations. The International Code Council (ICC) creates and revises this model IBC Code in three-year cycles as a standard for local municipal adoption.

The latest edition of this code being proposed for adoption by the Village is titled "2015 IBC, International Building Code". The ICC organization has made numerous changes to their 2015 edition from that of their currently adopted 2012 edition.

The Development Services Department has reviewed these ICC changes and has inserted existing amendments in addition to State mandated Codes, some of which include: Energy, Accessibility, Plumbing, and ILCS compiled statutes. All amendments are now referenced in The Village Code Sections 5-1-13, 5-1-14 and 5-1-15.

A key change to the new ICC, 2015/Building Code's has involved a vast modification to its Chapter 5, in the methods used in calculating allowable building heights and areas permitted for each building type. It is intended for the 2012/IBC method of regulation(s) to not change however this created some amendments for maintaining our current code as shown in Chapter 5. This ordinance proposal also clearly deletes fire sprinkler protection for single family and row dwellings construction as referenced by the model codes.

This proposal has included two new Village Code Sections, 5-1-14 and 5-1-15. 5-1-14 is now specific to single family and row residential units of wood frame construction, with formal adoption of the International Residential Code as amended. Village Code 5-1-15 is added, relocating our Violations and Penalties Sections to reference both the Commercial construction (5-1-13) and Residential construction (5-1-14). This Section is revised to be uniform with other Village Code Violation standards.

The proposed local changes are limited and intended to clarify existing rules by removing outdated construction standards. Building Division staff has highlighted these draft code changes and deletions for your review and will provide answers to any questions.

The Illinois Building Commission has been notified of Orland Park's intention to adopt a new building code/energy code with amendments as required by a recent act of the 92nd General Assembly.

I move to pass Ordinance Number 5105, entitled: AN ORDINANCE AMENDING THE VILLAGE CODE TO ADOPT THE 2015 INTERNATIONAL BUILDING CODE WITH AMENDMENTS, TO ADOPT THE 2015 INTERNATIONAL RESIDENTIAL CODE WITH AMENDMENTS, AND TO MAKE CERTAIN OTHER AMENDMENTS TO THE ORLAND PARK BUILDING CODE AND TO TITLE 5, CHAPTER 1 OF THE VILLAGE CODE OF THE VILLAGE OF ORLAND PARK.

This matter was PASSED on the Consent Agenda.

2016-0459 7420 W. 159th Street Planned Unit Development - Plat of Subdivision

On November 16, 2015, the Village Board of Trustees approved the special use permit to allow a Planned Unit Development at 7420 W. 159th Street. The approval established a four lot subdivision, with a single out-lot for the storm water management facility/ detention pond.

I move to approve the Plat of Subdivision for the 7420 W. 159th Street Planned Unit Development, titled "GW Property Subdivision Orland Park, Illinois", prepared by Manhard Consulting Ltd., and dated May 5, 2016 (printed Mylar).

This matter was APPROVED on the Consent Agenda.

TECHNOLOGY, INNOVATION AND PERFORMANCE IMPROVEMENT

2016-0447 Village Hall Data Center Air Conditioning - Approve Purchase

The Air Conditioning system (A/C) used to cool and maintain temperature in the Village Hall data center has failed and is in need of immediate replacement. The existing system is nearly 20 years old and repairs are problematic due to part unavailability and the antiquated design of the system. To continue operations, the data center is being cooled by a portable, corded A/C unit.

The Village Hall data center houses several servers, virtual server systems, computer switches, broadcasting equipment and serves as the central hub for most of the Village's information storage and computing needs. The computer equipment in the data center has specific operating temperature requirements and overheating of the room can lead to equipment shut down and/or damage.

Due to the urgency of the matter, staff initiated the purchase of a replacement A/C system. Before the procurement process was initiated, staff obtained three (3) quotes from reputable vendors to ensure that the best pricing would be attained for the new system. Quotes were received from Gustave A. Larson Company of Lombard, Illinois, Windy City Representatives of Oak Brook, Illinois and G.W. Berkheimer Co., Inc. of Tinley Park, Illinois. In addition to the three (3) quotes, staff engaged Control Technology Solutions Group (CTS Group), the Village's energy and efficiency consultant, to review the proposed system specifications. CTS Group endorses the solution.

The quote received from Gustave A. Larson Company of Lombard, Illinois was the lowest cost vendor that could provide the units immediately, at a total cost of \$10,908. This purchase will be for equipment only with staff from Public Works - Building Maintenance division performing the installation.

I move to waive the bid process;

And

Approve accepting the quote from Gustave A. Larson Company of Lombard, Illinois for the purchase of the replacement Village Hall Data Center Air Conditioning system in an amount not to exceed \$10,908.

A motion was made by Trustee Griffin Ruzich, seconded by Trustee Carroll, that this matter be APPROVED. The motion carried by the following vote:

Aye: 6 - Trustee Fenton, Trustee Gira, Trustee Griffin Ruzich, Trustee Calandriello, Trustee Carroll, and President McLaughlin

Nay: 0

Absent: 1 - Trustee Dodge

DEVELOPMENT SERVICES, PLANNING AND ENGINEERING

2016-0454 Wayfinding and Branding Plan - Adoption

Director of Development Services Karie Friling introduced Jodi Mariano, Project Manager, Teska Associates who gave a brief presentation on the proposed Wayfinding and Branding Plan.

On August 18, 2014 the Village Board approved Teska Associates to prepare a wayfinding and branding plan for the Village. Over the past year and a half Teska collected information, met with staff, the steering committee and facilitated public input to prepare a draft wayfinding and branding plan that is now before the Village Board of Trustees for approval.

Throughout this project Teska has worked with Village staff, the steering committee and the community to develop a wayfinding and branding plan that tells the unique story of Orland Park's special identity. The consultant team prepared wayfinding signage at a conceptual design level, including general locations of proposed signs and proposed copy text. Concepts were developed for the following sign types:

- Vehicular Directional Signs
- Village Gateway Signs
- Historic District Signs
- Municipal Signs
- Park Signs
- Bicycle Directional Signs

The draft plan outlines the planning process for the project. This included:

- A study of Existing Conditions including sign inventory
- Assessment of existing branding efforts
- Community Survey and Focus Groups
- Public Open House
- Visioning Sessions with the Steering Committee
- Presentation to staff and elected officials to select preferred signage and branding design
- Formal Plan Adoption

In addition to signage and branding design elements, the consultant prepared a wayfinding signage plan that identifies potential locations for wayfinding signage and provides recommendations for text on the signs at each location. They have also prepared engineering documents that outline the appropriate location for signage based on state, local and federal standards.

The consultant team along with Village Staff and the steering committee also identified priority areas where the Village should begin installing wayfinding signage. The consultant has provided sign mock ups and shop drawings for the priority areas. The priority areas for implementation:

Phase 1

Gateway Monument Signs at 143rd St. and Will Cook Rd., 159th Street and Will Cook Road, Southwest Highway near Will Cook Rd., Harlem Ave. and 159th St., and Harlem Ave. and 143rd St.

LaGrange Road Medians
LaGrange Road Directional Signs
Village Center Sign Retrofit

Phase 2

Ravinia Ave. Directional Signs
Ravinia Ave. Municipal Signs

Phase 3

159th St. Directional Signs
Other Areas as Identified

\$150,000 has been budgeted to begin implementation. After the plan is formally approved staff will initiate the RFQ process to select a sign manufacturer and begin implementing the wayfinding program based on the recommendations in the plan.

In addition to signage, this new Village logo will be used for correspondence and marketing throughout the Village. Below is a list of potential items that are planned to be updated with the new logo:

Village Letterhead / Business Cards
Water Towers
Correspondence/Applications
Village Vehicles
Furniture / Garbage Cans at Village Parks and Buildings
Clothing / Uniforms
Parking Deck in Downtown Orland Park

Examples of some of these applications have been provided to the Village Board for review.

This list is not all inclusive but was included as a reminder that the new Village branding initiative is not solely for signage. The brand needs to be incorporated throughout the entire Village. The implementation will likely be phased, will have to include cooperation from all Village departments, and will be utilized for various applications. Consistent use of the brand will result in regional recognition over time.

I move to approve adoption of the Wayfinding and Branding Plan, prepared by Teska Associates in coordination with Wohlt Group, Gewalt Hamilton Associates, Inc., and Parvin Clauss Sign Company, titled, "Wayfinding and Branding Program Village of Orland Park."

A motion was made by Trustee Fenton, seconded by Trustee Calandriello, that this matter be APPROVED. The motion carried by the following vote:

Aye: 6 - Trustee Fenton, Trustee Gira, Trustee Griffin Ruzich, Trustee Calandriello, Trustee Carroll, and President McLaughlin

Nay: 0

Absent: 1 - Trustee Dodge

PARKS AND RECREATION

2016-0457 2016 Summer/Fall Senior Program Guide

At the request of the Recreation Committee Chair, staff has created a Senior Program Guide to include senior events and programs offered by the Village of Orland Park. The goal is to capture our senior audience and to engage them in the various opportunities in the Village. This Summer/Fall program guide will highlight all senior programs, special events, opportunities, and other Orland Park partner offerings tailored for the senior population.

Staff solicited three quotes for the printing of 9,000 program guide copies; 7,355 to be mailed to senior residents. The remaining copies will be distributed in all Village buildings and at events throughout the seasons.

The specifications for the piece are 9,000 copies, 8.125 x 10.625, 40 pages, 4/4 with bleeds, 80Lb. Dull Cover/ 80# Dull Text / 50Lb. White Offset, saddle stitch and prepare for USPS mailing. FOB 7,355 to be delivered to the Orland Park Post Office, and the remaining 1,645 delivered to the Village of Orland Park Recreation Administration Office.

The quotes are as follows:

M & G Graphics \$8,043.69
Solution 3 Graphics \$9,247.42
Liberty Creative Solutions \$9,890

Staff is recommending the lowest quote from M & G Graphics.

This agenda item is being considered by the Parks and Recreation Committee and the Village Board of Trustees on the same night.

I move to approve the quote from M & G Graphics to print the 2016 Summer/Fall Senior Program Guide.

A motion was made by Trustee Gira, seconded by Trustee Fenton, that this matter be APPROVED. The motion carried by the following vote:

Aye: 6 - Trustee Fenton, Trustee Gira, Trustee Griffin Ruzich, Trustee Calandriello, Trustee Carroll, and President McLaughlin

Nay: 0

Absent: 1 - Trustee Dodge

2016-0460 Norm Meyer's Special Day for Special People - Payment Approval

The annual Norm Meyer's event was hosted on Thursday, June 2, 2016 at Centennial Park in Orland Park. This event was well attended by Orland Park's Special Recreation participants, as well as invited Special Recreation agencies. There were approximately 1,500-2,000 participants at this event.

The Village pays for the initial costs to run this event. The Lions Club of Orland Park reimburses the Village of Orland Park 100% for all program costs for the Norm Meyer's Special Day for Special People.

In previous years, the Lions Club paid the vendor directly for the participants' T-shirts. This year staff purchased T-shirts directly from Palos Sports, who provided a lower cost per shirt than the previous vendor.

The T-shirts were distributed to all volunteers and program participants at a cost of \$6,037 for the first payment, and \$360 for the second payment. The total T-shirt cost for this event is \$6,397.

This agenda item is being considered by the Parks and Recreation Committee and the Village Board of Trustees on the same night.

I move to approve payment for the Norm Meyer's Special Day T-shirts in the amount of \$6,397.

A motion was made by Trustee Gira, seconded by Trustee Fenton, that this matter be APPROVED. The motion carried by the following vote:

Aye: 6 - Trustee Fenton, Trustee Gira, Trustee Griffin Ruzich, Trustee Calandriello, Trustee Carroll, and President McLaughlin

Nay: 0

Absent: 1 - Trustee Dodge

MAYOR'S REPORT

2016-0432 Vietnam War 50th Anniversary Commemorative Partnership Event

President McLaughlin reported that as a part of our Vietnam War 50th Anniversary Commemorative Partnership with the Department of Defense, the Village of Orland Park & our Veterans Commission will host, "One Vet to Another -- A Night with Rocky Bleier." Rocky Bleier is a Vietnam Veteran, recipient of the Purple Heart and a Bronze Star, former Pittsburgh Steeler of National Football League,

and a nationally renowned motivational speaker.

The goal is to thank Orland Park Vietnam veterans for their service and sacrifice. The reception will be at Palos Country Club November 4, 2016. Rocky Bleier's fee is \$10,000.

A sponsorship request has been sent to the NFL and the Chicago Bears. Various sponsorship levels are available. Currently potential sponsors are being approached by Mayor McLaughlin and members of the Veterans Commission.

I move to approve contracting for Rock Bleier's appearance at a cost of \$10,000.

A motion was made by Trustee Carroll, seconded by Trustee Calandriello, that this matter be APPROVED. The motion carried by the following vote:

Aye: 6 - Trustee Fenton, Trustee Gira, Trustee Griffin Ruzich, Trustee Calandriello, Trustee Carroll, and President McLaughlin

Nay: 0

Absent: 1 - Trustee Dodge

VILLAGE MANAGER'S REPORT

2016-0440 Extension of Memorandum of Understanding with St. George Corporation, St. George Wellness Center and Palos Community Hospital

President McLaughlin reported that the Memorandum Of Understanding (MOU) with St. George Corporation and Palos Community Hospital dated March 23, 2016, regarding the transfer to the Village of the Palos Fitness Center is to expire on June 21, 2016, unless the parties agree to an extension. As the parties are actively negotiating the terms of the land transfer/exchange and the Village continues its "due diligence" review of the terms of the transaction, it appears final approval by the parties will not be achieved by the June 21st date. Consequently, it is recommended that the parties execute an extension of the MOU to August 1, 2016, and an Extension Agreement to that effect is attached in Legistar for Village Board consideration and approval.

During this period, the fitness center will remain open. Staff has been working with Palos to review pertinent financial information, building and capital assessments of the existing center, operations and programming, and final site plan reconfiguration. Staff will provide a report of each of these areas with the proposed development agreement. The final terms of the development agreement and related documents that will address the long term preservation of the fitness center and the ultimate build-out of Palos' expansion plans, is tentatively scheduled to be brought to the Board on July 18th for approval.

I move to approve the extension of the Memorandum of Understanding between the Village of Orland Park and St. George Corporation, St. George Wellness

Center and Palos Community Hospital and to authorize the Village Manager to execute the Memorandum of Understanding.

A motion was made by Trustee Fenton, seconded by Trustee Calandriello, that this matter be APPROVED. The motion carried by the following vote:

Aye: 6 - Trustee Fenton, Trustee Gira, Trustee Griffin Ruzich, Trustee Calandriello, Trustee Carroll, and President McLaughlin

Nay: 0

Absent: 1 - Trustee Dodge

NON-SCHEDULED CITIZENS & VISITORS

Marion Nowakowski, 14828 South Jefferson Avenue – spoke before the Board regarding a rendering that has been released of the new downtown area. On her block the first five homes are represented in this rendering by trees only, none of the homes are visible. She has lived in this home for over 40 years and would like to know what the Village's plans are for those five homes. She does not want to move from her home.

President McLaughlin stated and Village Manager Grimes echoed that there are no plans for this block and they do not understand why those five homes were not shown. It could have been a spacing issue in the rendering that did not allow the homes to be shown.

Ms. Nowakowski was reassured that there are no plans for her block.

BOARD COMMENTS

TRUSTEE GIRA – Announced the sale of scented candles that were made by the Village's Special Recreation Program participants. She brought in some examples of these scented candles. This past Farmer's Market all the inventory was sold out and now the Special Recreation Program is replenishing their inventory and these candles will once again go on sale toward the end of the season at the Farmer's Market. These make beautiful gifts.

Trustee Gira stated that at tonight's meeting the first Summer/Fall Senior Program Guide was approved that will be mailed out by July 1st. This booklet will include events and programs for Village Seniors. Another booklet will be mailed in January, 2017 that will include Winter/Spring Senior activities.

TRUSTEE CARROLL – Reminded residents that the even/odd watering restrictions are in effect for the summer.

If a resident has newly planted grass or landscaping, they can call Public Works to receive an exemption permit and they would be allowed to water every day.

TRUSTEE RUZICH – Kudo's to staff on continuing to work so hard on wrapping up the Palos Health and Fitness Center agreement.

TRUSTEE CALANDRIELLO – Reminded residents that tonight the Police Department is having a hot dog cookout event in the Village Square Park. This is a great event to meet the Police Officers in the community.

Next week on Tuesday (6/28) and Wednesday (6/29) the Police Department is hosting a two day Teen Academy.

TRUSTEE FENTON – Thanked staff and other individuals from the community that helped with the Wayfinding project that was just approved this evening.

Trustee Fenton reminded everyone that the Centennial Park West Concert Event will be held on Sunday, July 3rd from 5 PM to 7 PM featuring The City Lights Orchestra.

The Independence Day Celebration is Monday, July 4th at Centennial Park. "The Breakfast Club" will be performing at 7:15 PM followed by fireworks at 9:15 PM.

EXECUTIVE SESSION

I move to recess to a Closed Executive Session for the purpose of discussion of a) approval of minutes; b) the appointment, employment, compensation, discipline, performances or dismissal of specific village employees; c) the selection of a person to fill a public office or the discipline, performance or removal of the occupant of a public office; and d) setting a price for sale or lease of village property.

A motion was made by Trustee Fenton, seconded by Trustee Griffin Ruzich, that this matter be RECESS. The motion carried by the following vote:

Aye: 6 - Trustee Fenton, Trustee Gira, Trustee Griffin Ruzich, Trustee Calandriello, Trustee Carroll, and President McLaughlin

Nay: 0

Absent: 1 - Trustee Dodge

RECONVENE BOARD MEETING

The roll was called to reconvene the Regular Meeting and Trustees Fenton, Gira, Ruzich, Calandriello, Carroll and President McLaughlin were present. Trustee Dodge was absent.

Purpose of the Executive Session was for the discussion of a) approval of minutes; b) the appointment, employment, compensation, discipline, performances or dismissal of specific village employees; c) the selection of a person to fill a public office or the discipline, performance or removal of the occupant of a public office; and d) setting a price for sale or lease of village property.

ADJOURNMENT - 9:10 PM

A motion was made by Trustee Fenton, seconded by Trustee Griffin Ruzich, that this matter be ADJOURNED. The motion carried by the following vote:

Aye: 6 - Trustee Fenton, Trustee Gira, Trustee Griffin Ruzich, Trustee Calandriello, Trustee Carroll, and President McLaughlin

Nay: 0

Absent: 1 - Trustee Dodge

APPROVED:

/nm

Respectfully Submitted,

John C. Mehalek, Village Clerk

Casey Griffin, Deputy Clerk

DATE: July 5, 2016

REQUEST FOR ACTION REPORT

File Number:	2016-0476
Orig. Department:	Village Clerk
File Name:	Saint Michael's Parish - Raffle License

BACKGROUND:

St. Michael's is requesting a license to sell raffle tickets beginning July 6, 2016 and during their St. Michael's Fall Fest beginning Thursday, September 15, 2016 through Sunday, September 18, 2016, in the St. Michael's parking lot. The raffle drawing will be held on Sunday, September 18, 2016 at 5:00 PM.

The purpose for this raffle is to benefit St. Michael's Parish.

All required documents have been submitted.

BUDGET IMPACT:

REQUESTED ACTION:

I move to approve issuing a raffle license to St. Michael's Church so tickets may be sold beginning July 6, 2016 and during their St. Michael's Fall Fest beginning Thursday, September 15, 2016 through Sunday, September 18, 2016.

VILLAGE OF ORLAND PARK
14700 RAVINIA AVENUE
ORLAND PARK, IL 60462

2016
APPLICATION FOR LICENSE TO SELL
RAFFLE TICKETS
(This is a two-sided application)

(To be completed by Village staff)

Date Approved: _____
Date Denied: _____
Approval: _____
Village Clerk
Expires: _____

**APPROVED APPLICATION
SERVES AS LICENSE**

PLEASE NOTE: Any misrepresentation or falsification of the information sought below may result in revocation of the License as granted. **Applications must be submitted at least 30 days prior to the raffle date requested.** For information or questions, please call (708) 403-6150.

~Each license is valid for not more than 1 raffle per week during any 1 year period.~

**NAMES OF UNDERSIGNED ORGANIZATION OFFICERS
(PERSONS SUBMITTING APPLICATION)**

DATE OF APPLICATION: 6-16-16
PRESIDENT OR PRESIDING OFFICER: Fr. Paul Burak
SECRETARY: Dee Pietrzak
ADDRESS OF APPLICANT: 14327 Highland
Orland Park, IL 60462

ORGANIZATION REQUESTING LICENSE: St. Michael Parish

ADDRESS OF ORGANIZATION: 14327 Highland
Orland Park, IL 60462

NAME AND ADDRESS OF RAFFLE MANAGER: Dee Pietrzak
14327 Highland
PHONE 708-349-0903

ADDRESS OF PLACE(S) OR AREA(S) WHERE CHANCES ARE TO BE SOLD OR ISSUED:

14327 Highland
PURPOSE OF RAFFLE: Fundraiser for St. Michael Parish

TIME PERIOD WHICH RAFFLE CHANCES WILL BE SOLD OR ISSUED: Thru 9/18/16

MAXIMUM NUMBER OF RAFFLE CHANCES TO BE SOLD OR ISSUED: 44,000

PRICE OF CHANCES: \$20 TOTAL PRIZE VALUE: \$20,500.00 LARGEST SINGLE PRIZE: \$10,000.00

TIME, DATE AND LOCATION WHERE WINNING RAFFLE CHANCE WILL BE DETERMINED:

5:00 PM 9/18/16 14327 Highland O.P. IL
Time Date Location of Raffle Drawing (Address, City, State)

OVER

CHECK TYPE OF NON-PROFIT ORGANIZATION AND ATTACH DOCUMENTATION

Religious _____ Charitable _____ Labor _____ Fraternal _____ Business _____

Educational _____ Veterans' Organization _____ *Non-Profit Fund Raising _____

**(check this box if organized solely to raise funds for an individual or group of individuals suffering extreme financial hardship, as a result of illness, disability, accident or disaster)*

LENGTH OF TIME ORGANIZATION HAS BEEN IN EXISTENCE: 148 years

PLACE AND DATE OF INCORPORATION OF ORGANIZATION: _____

IF NOT A CORPORATION, STATE WHEN AND HOW ORGANIZED: —

Archdiocese of Chicago

NUMBER OF MEMBERS OF ORGANIZATION THAT RESIDE IN VILLAGE: 13,560

The undersigned, under oath attest that we have read and understand Ordinance #3480 entitled "An ordinance of the Village of Orland Park establishing a system for the licensing of organizations to operate raffles" and we further attest to the non-profit character of the prospective license organization.

Further the undersigned attest that they comply with all provisions of Ordinance #3480 and understand that violations of this ordinance are subject to fines of not less than one-hundred dollars (\$100.00) and not more than seven-hundred-and-fifty dollars (\$750.00) per violation.

President or Presiding Officer Fr. Paul Burak
Type or Print Name

Signature: [Handwritten Signature]

ATTEST:
Secretary: Dee Pietrzak
Type or Print Name

Signature: [Handwritten Signature]

SUBSCRIBED AND SWORN TO

before me this 17th
day of June, 2006.

[Handwritten Signature]
(Notary Public)



Commission Expires: April 20, 2020

DATE: July 5, 2016

REQUEST FOR ACTION REPORT

File Number: **2016-0481**
Orig. Department: **Village Clerk**
File Name: **In Search of a Cure - Raffle License**

BACKGROUND:

In Search of a Cure is requesting a license to sell raffle tickets during their annual golf event on Thursday, July 28, 2016 at Silver Lakes Country Club.

All required documents have been submitted.

BUDGET IMPACT:

REQUESTED ACTION:

I move to approve issuing a raffle license to In Search of a Cure to sell raffle tickets during their annual golf event on Thursday, July 28, 2016 at Silver Lakes Country Club.

VILLAGE OF ORLAND PARK
14700 RAVINIA AVENUE
ORLAND PARK, IL 60462

2016
APPLICATION FOR LICENSE TO SELL
RAFFLE TICKETS
(This is a two-sided application)

(To be completed by Village staff)

Date Approved: _____
Date Denied: _____
Approval: _____
Village Clerk
Expires: _____

**APPROVED APPLICATION
SERVES AS LICENSE**

PLEASE NOTE: Any misrepresentation or falsification of the information sought below may result in revocation of the License as granted. **Applications must be submitted at least 30 days prior to the raffle date requested.** For information or questions, please call (708) 403-6150.
~Each license is valid for not more than 1 raffle per week during any 1 year period.~

**NAMES OF UNDERSIGNED ORGANIZATION OFFICERS
(PERSONS SUBMITTING APPLICATION)**

DATE OF APPLICATION: June 28, 2016

PRESIDENT OR PRESIDING OFFICER: Terrence Hancock

SECRETARY: Roberta Lester

ADDRESS OF APPLICANT: 14551 S. Ravinia, Ste 2B
Orland Park, IL 60462

ORGANIZATION REQUESTING LICENSE: In Search of a Cure

ADDRESS OF ORGANIZATION: 14551 S. Ravinia, Ste. 2B
Orland Park, IL 60462

NAME AND ADDRESS OF RAFFLE MANAGER: Roberta Lester
14551 S. Ravinia, Ste 2B, Orland Park, IL 60462

PHONE 630-887-4141

ADDRESS OF PLACE(S) OR AREA(S) WHERE CHANCES ARE TO BE SOLD OR ISSUED:
Silver Lakes Country Club

PURPOSE OF RAFFLE: Raise funds for charitable purposes

TIME PERIOD WHICH RAFFLE CHANCES WILL BE SOLD OR ISSUED: July 28, 2016

MAXIMUM NUMBER OF RAFFLE CHANCES TO BE SOLD OR ISSUED: July 28, 2016

PRICE OF CHANCES: Various TOTAL PRIZE VALUE: \$20,000 LARGEST SINGLE PRIZE: \$10,000

TIME, DATE AND LOCATION WHERE WINNING RAFFLE CHANCE WILL BE DETERMINED:

7PM July 28, 2016 Silver Lakes Country Club
Time Date Location of Raffle Drawing (Address, City, State)

OVER

CHECK TYPE OF NON-PROFIT ORGANIZATION AND ATTACH DOCUMENTATION

Religious _____ Charitable XX Labor _____ Fraternal _____ Business _____

Educational _____ Veterans' Organization _____ *Non-Profit Fund Raising _____

*(check this box if organized solely to raise funds for an individual or group of individuals suffering extreme financial hardship, as a result of illness, disability, accident or disaster)

LENGTH OF TIME ORGANIZATION HAS BEEN IN EXISTENCE: 8 yrs

PLACE AND DATE OF INCORPORATION OF ORGANIZATION: Illinois 04/16/08

IF NOT A CORPORATION, STATE WHEN AND HOW ORGANIZED: _____

NUMBER OF MEMBERS OF ORGANIZATION THAT RESIDE IN VILLAGE: 1

The undersigned, under oath attest that we have read and understand Ordinance #3480 entitled "An ordinance of the Village of Orland Park establishing a system for the licensing of organizations to operate raffles" and we further attest to the non-profit character of the prospective license organization.

Further the undersigned attest that they comply with all provisions of Ordinance #3480 and understand that violations of this ordinance are subject to fines of not less than one-hundred dollars (\$100.00) and not more than seven-hundred-and-fifty dollars (\$750.00) per violation.

President or Presiding Officer

Terrence Hancock
Type or Print Name

Signature:

Terrence Hancock

ATTEST:

Secretary:

Roberta Lester
Type or Print Name

Signature:

Roberta Lester

SUBSCRIBED AND SWORN TO

before me this 20th
day of June, 2016.

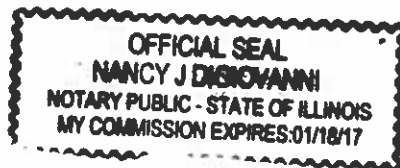

Nancy J. DiStovanni
(Notary Public)

Commission Expires: 1/18/17

DATE: July 5, 2016

REQUEST FOR ACTION REPORT

File Number: **2016-0475**
Orig. Department: **Village Clerk**
File Name: **Catholic Charities - Raffle License**

BACKGROUND:

Catholic Charities of the Archdiocese of Chicago is requesting a license to sell raffle tickets beginning July 6, 2016 for their event on August 1, 2016 at the Crystal Tree Golf and Country Club. Funds raised are to benefit the Loving Outreach to Survivors of Suicide (LOSS) program.

All required documents have been submitted.

BUDGET IMPACT:

REQUESTED ACTION:

I move to approve issuing a raffle license to Catholic Charities to sell raffle tickets beginning July 6, 2016 for their event on Monday, August 1, 2016 at the Crystal Tree Golf and Country Club.

VILLAGE OF ORLAND PARK
14700 RAVINIA AVENUE
ORLAND PARK, IL 60462

2016
**APPLICATION FOR LICENSE TO SELL
RAFFLE TICKETS**
(This is a two-sided application)

(To be completed by Village staff)

Date Approved: _____
Date Denied: _____
Approval: _____
Village Clerk
Expires: _____

**APPROVED APPLICATION
SERVES AS LICENSE**

PLEASE NOTE: Any misrepresentation or falsification of the information sought below may result in revocation of the License as granted. Applications must be submitted at least 30 days prior to the raffle date requested. For information or questions, please call (708) 403-6150.

-Each license is valid for not more than 1 raffle per week during any 1 year period.-

**NAMES OF UNDERSIGNED ORGANIZATION OFFICERS
(PERSONS SUBMITTING APPLICATION)**

DATE OF APPLICATION: June 16, 2016

PRESIDENT OR PRESIDING OFFICER: Monsignor Michael M. Boland, Administrator, President & CEO

SECRETARY: Mr. Michael Y. Scudder, Jr.

ADDRESS OF APPLICANT: 721 N. LaSalle, Chicago, IL 60654

ORGANIZATION REQUESTING LICENSE: Catholic Charities of the Archdiocese of Chicago

ADDRESS OF ORGANIZATION: 721 N. LaSalle, Chicago, IL 60654

NAME AND ADDRESS OF RAFFLE MANAGER: Mr. Dave Gardner

721 N. LaSalle, Chicago, IL 60654

PHONE: (312) 655-7907

ADDRESS OF PLACE(S) OR AREA(S) WHERE CHANCES ARE TO BE SOLD OR ISSUED: Chances will be sold on the day of the event at Crystal Tree Golf and Country Club, 10700 W. 53rd St., Orland Park, IL 60462 and online prior to the event.

PURPOSE OF RAFFLE: To benefit the Loving Outreach to Survivors of Suicide (LOSS) Program.

TIME PERIOD WHICH RAFFLE CHANCES WILL BE SOLD OR ISSUED: June 1, 2016 to August 1, 2016

MAXIMUM NUMBER OF RAFFLE CHANCES TO BE SOLD OR ISSUED: 600

PRICE OF CHANCES: \$50.00 each or 3 for \$100.00 **TOTAL PRIZE VALUE:** \$4,000.00 **LARGEST SINGLE PRIZE:** \$2,000.00

TIME, DATE AND LOCATION WHERE WINNING RAFFLE CHANCE WILL BE DETERMINED:

Approximately 7:30 p.m. August 1, 2016 Crystal Tree Golf and Country Club, 10700 W. 53rd St., Orland Park, IL 60462 **OVER**

Time Date Location of Raffle Drawing (Address, City, State)

CHECK TYPE OF NON-PROFIT ORGANIZATION AND ATTACH DOCUMENTATION

Religious _____ Charitable X Labor _____ Fraternal _____ Business _____

Educational _____ Veterans' Organization _____ *Non-Profit Fund Raising _____

**(check this box if organized solely to raise funds for an individual or group of individuals suffering extreme financial hardship, as a result of illness, disability, accident or disaster)*

LENGTH OF TIME ORGANIZATION HAS BEEN IN EXISTENCE: 98 Years

PLACE AND DATE OF INCORPORATION OF ORGANIZATION: Illinois, January 21, 1918

IF NOT A CORPORATION, STATE WHEN AND HOW ORGANIZED: N/A (See above)

NUMBER OF MEMBERS OF ORGANIZATION THAT RESIDE IN VILLAGE: _____

The undersigned, under oath attest that we have read and understand Ordinance #3480 entitled "An ordinance of the Village of Orland Park establishing a system for the licensing of organizations to operate raffles" and we further attest to the non-profit character of the prospective license organization.

Further the undersigned attest that they comply with all provisions of Ordinance #3480 and understand that violations of this ordinance are subject to fines of not less than one-hundred dollars (\$100.00) and not more than seven-hundred-and-fifty dollars (\$750.00) per violation.

President or Presiding Officer Monsignor Michael M. Boland, Administrator, President & CEO
Type or Print Name

Signature: *[Handwritten Signature]* 6/16/2016

ATTEST: *[Handwritten Signature]* 6/16/2016

Secretary: Mr. Michael Y. Scudder, Jr.
Type or Print Name

Signature: _____

SUBSCRIBED AND SWORN TO

before me this 6/16/2016
day of 16th, 2016.

[Handwritten Signature]
(Notary Public)



Commission Expires: AUGUST 23, 2016

DATE: July 5, 2016

REQUEST FOR ACTION REPORT

File Number: **2016-0473**
Orig. Department: **Officials**
File Name: **Community Pride Award - Grace Rost**

BACKGROUND:

Mayor McLaughlin will present a Community Pride Award to Grace Rost in recognition of earning the Girl Scouts Gold Award. The Gold Award is the highest achievement within the Girl Scouts of the USA.

BUDGET IMPACT:

REQUESTED ACTION:

DATE: July 5, 2016

REQUEST FOR ACTION REPORT

File Number:	2016-0474
Orig. Department:	Officials
File Name:	Community Pride Award - Victoria Kappel

BACKGROUND:

Mayor McLaughlin will present a Community Pride Award to Victoria Kappel in recognition of being selected one of the 2016 NCAA Postgraduate Scholars and the first female student-athlete at Western Illinois University to receive this national academic scholarship award.

BUDGET IMPACT:

REQUESTED ACTION:

DATE: July 5, 2016

REQUEST FOR ACTION REPORT

File Number:	2016-0488
Orig. Department:	Finance Department
File Name:	Payroll - Approval

BACKGROUND:

BUDGET IMPACT:

REQUESTED ACTION:

I move to approve the Bi-Weekly Payroll for July 1, 2016 in the amount of \$1,214,198.36.

Bi-Weekly Payroll for July 1, 2016

VILLAGE MANAGER	31,549.93
VILLAGE CLERK	11,663.80
PUBLIC INFORMATION	4,997.80
FINANCE	44,493.48
OFFICIALS	9,949.87
M.I.S.	12,835.20
BUILDING MAINTENANCE	25,479.35
DEVELOPMENT SERVICES - ADMINISTRATION DIVISION	21,375.60
DEVELOPMENT SERVICES - BUILDING DIVISION	29,696.96
DEVELOPMENT SERVICES - PLANNING DIVISION	18,603.86
DEVELOPMENT SERVICES - TRANSPORTATION & ENGINEERING DIV	12,652.80
PUBLIC WORKS - ADMINISTRATION	24,757.07
PUBLIC WORKS - STREETS	77,642.92
PUBLIC WORKS - TRANSPORTATION	4,124.10
PUBLIC WORKS - VEHICLE & EQUIPMENT	16,912.71
POLICE	468,474.33
CIVIC CENTER	5,025.06
PUBLIC WORKS - WATER & SEWER	53,379.38
RECREATION - ADMINISTRATION	79,977.57
RECREATION - PROGRAMS	35,724.54
RECREATION - PARK OPERATIONS	79,069.91
RECREATION - CENTENNIAL POOL	99,526.65
RECREATION - SPORTSPLEX	22,139.88
RECREATION - SPECIAL RECREATION	24,145.59
GROSS PAY	\$ 1,214,198.36
AFSCME DUES	(1,733.22)
IBEW DUES	(191.69)
IUOE DUES	(993.98)
ORLAND POLICE SUPERVISOR DUES	(190.00)
POLICE PENSION	(34,073.95)
POLICE PENSION TRUE COST	-
IMRF VOLUNTARY LIFE INSURANCE	-
POLICE - M.A.P. DUES	(1,309.00)
SOCIAL SECURITY TAX	(51,783.03)
MEDICARE TAX	(17,202.14)
IMRF	(27,653.41)
IMRF - SLEP PLAN	(459.58)
IMRF - VOLUNTARY ADD'L CONTRIBUTION	(6,767.87)
FEDERAL TAX	(140,070.81)
STATE TAX	(39,745.05)
ICMA DEFERRED	(1,804.85)
NATIONWIDE DEFERRED	(7,268.08)
MASS MUTUAL DEFERRED	(26,445.84)
AXA DEFERED	(405.00)
HEALTH INSURANCE - EMPL CONTRIBUTIONS	(14,173.21)
HDHP HEALTH INSURANCE - EMPL CONTRIBUTIONS	(9,394.07)
HDHP HEALTH INSURANCE - EMPL DISBURSEMENTS	9,394.07
FLEXIBLE SPENDING ACCOUNTS	(1,916.42)
VACATION PURCHASE PROGRAM	(1,904.64)
AFLAC INSURANCES	(740.17)
CAIC INSURANCES	(495.70)
NATIONAL GUARDIAN INSURANCE	(39.01)
SUPPORT	(8,168.04)
GARNISHMENTS	(425.60)
MISCELLANEOUS DEDUCTION	-
MILITARY BASIC PAY DEDUCTION	-
NET PAY	\$ 828,238.07

DATE: July 5, 2016

REQUEST FOR ACTION REPORT

File Number:	2016-0489
Orig. Department:	Finance Department
File Name:	Accounts Payable - Approval

BACKGROUND:

BUDGET IMPACT:

REQUESTED ACTION:

I move to approve the Accounts Payable from June 21, 2016 through July 5, 2016 in the amount of \$2,897,712.73.

Village of Orland Park Open Item Listing

Run Date: 07/01/2016 User: bobrien

Status: POSTED Due Date: 07/05/2016
Bank Account: BMO Harris Bank-Vendor Disbursement
Invoice Type: All Created By: All

Vendors	Vendor Invoice	Invoice	Purchase Order	Due Date	Line No	Line Item Description	Account Number	Amount
[VENDOR] 1100 : G.W. BERKHEIMER CO., INC.	748034	116-013696	16-000198	06/27/2016	1	Machinery/equipment parts for CPAC	283-4005-461700	\$ 70.37
	749470	116-013697	16-000198	06/27/2016	1	Machinery/equipment parts for CPAC	283-4005-461700	\$ 96.11
	847797	116-013698	16-000198	06/27/2016	1	Pipe returns	283-4005-461700	\$ -401.57
[VENDOR] 1156 : COOK COUNTY RECORDER & REGISTRAR	2284302016JOSEPH	116-013502	16-001720	06/14/2016	1	Recording Fees - Development Agreement - 27-16-403-009 - 15882 S. LaGrange Road	010-2003-442300	\$ 74.00
	2284302016JOSEPH	116-013502	16-001720	06/14/2016	2	Recording Fees - Drainage Easement - 27-11-108-007 - 8609 W. 145th	031-6007-470500	\$ 50.00
	06/28/16	116-013825	16-001878	06/28/2016	1	To file weed lien - 8560 Pine St. PIN 27-02-105-010-0000	010-2002-442210	\$ 42.25
	06/28/16	116-013826	16-001875	06/28/2016	1	To file weed lien - 13601 S. 85th Avenue PIN 27-02-115-017-0000	010-2002-442210	\$ 42.25
	06/28/16	116-013827	16-001874	06/28/2016	1	To file weed lien - SE Corner of 159th & 88th Ave PIN 27-23-100-013-0000	010-2002-442210	\$ 42.25
	06/28/16	116-013828	16-001876	06/28/2016	1	To file weed lien - 8117 St. James Ct. PIN 27-14-213-009-0000	010-2002-442210	\$ 42.25
	06/28/16	116-013830	16-001877	06/28/2016	1	To file weed lien - 16801 Robinhood Drive PIN 27-26-109-001-0000	010-2002-442210	\$ 42.25
[VENDOR] 1165 : COM ED	0447033150	116-012617		07/05/2016	1	4/20-5/18/16	010-5002-441300	\$ 278.79
	1003150008	116-012632		07/05/2016	1	4/19-5/18/16	026-0000-441300	\$ 480.32
[VENDOR] 1249 : EFENGEE ELECTRICAL SUPPLY CO.	5025-500984	116-013869	16-001893	06/30/2016	1	600V IND FUSE	283-4005-461200	\$ 179.70
[VENDOR] 1323 : GRAINGER, INC.	9129152469	116-013864	16-000173	06/30/2016	1	Pipes - CPAC	283-4005-461700	\$ 32.78
	9127543339	116-013865	16-000173	06/30/2016	1	Pressure gauges - CPAC	283-4005-461700	\$ 357.48
	9127787753	116-013866	16-000173	06/30/2016	1	Anti-slip tape - CPAC	283-4005-461300	\$ 91.44
	9129152477	116-013867	16-001756	06/30/2016	1	Air Circulator 16in 2450 CFM 115v 2LY94	283-4007-460180	\$ 181.26
[VENDOR] 1343 : HALOGEN SUPPLY COMPANY, INC.	00486339	116-013769	16-001024	06/28/2016	1	CPAC Maintenance supplies	283-4005-461650	\$ 228.50
[VENDOR] 1376 : AT & T	Z99-2427	116-013650		06/24/2016	1	5/17-6/16/16	010-0000-441100	\$ 63.08
[VENDOR] 1472 : CONSERV FS	66005485	116-013776	16-000283	06/28/2016	1	Marking paint/Chalk	283-4003-461990	\$ 531.26
[VENDOR] 1593 : NEOPOST USA, INC.	06/20/16	116-013686		06/20/2016	1	Postage	010-0000-150110	\$ 4,000.00
[VENDOR] 1617 : ORLAND PARK POSTMASTER	06/15/16	116-013619	16-001760	07/05/2016	1	Distribution of the 2016 Summer/Fall Senior Program Guide to 7,355 senior residents	283-4001-441600	\$ 2,768.75
[VENDOR] 1659 : PLANNING RESOURCES, INC.	12143	116-013897	16-000936	06/30/2016	1	Orland Park Landscape Reviews - May	010-2003-432800	\$ 3,048.50
[VENDOR] 1696 : RED WING SHOE STORE	10-159	116-013915	16-000587	06/30/2016	1	Boots - Heidegger	283-4003-460190	\$ 139.49

Vendors	Vendor Invoice	Invoice	Purchase Order	Due Date	Line No	Line Item Description	Account Number	Amount
	11-159	I16-013916	16-000587	06/30/2016	1	Boots - Malloy	283-4003-460190	\$ 150.00
[VENDOR] 1747 : SECRETARY OF STATE	06/15/16	I16-013709	16-001775	06/27/2016	1	Notary Public Application Fee-Donna M Krzebiot	010-1400-429200	\$ 10.00
[VENDOR] 1884 : VILLAGE OF OAK LAWN	4627	I16-013870	16-001900	06/30/2016	1	Northern Trust Unused Commitment Fee	031-1400-480350	\$ 624.25
[VENDOR] 1894 : WASTE MANAGEMENT OF ILLINOIS	0025698-4936-3	I16-013689	16-000420	06/27/2016	1	30 Yard Dumpster for use for 30 days for the Well House on Wheeler Drive to dispose of Theatre sets	283-4002-442100	\$ 5.00
	0026134-4936-8	I16-013690	16-000420	06/27/2016	1	2nd Dumpster Rental for Well House - Orland Park Theatre Troupe	283-4002-442100	\$ 5.00
	1403014-4936-3	I16-013844	16-000175	06/29/2016	1	May	031-1400-442100	\$ 437,618.88
[VENDOR] 1924 : SIRCHIE	0248461-IN	I16-013649	16-000871	06/24/2016	1	LPW100, L.P. BAKCING CARD (WHT) 3x5/100	010-7002-460290	\$ 36.70
[VENDOR] 2033 : TRI-RIVER POLICE TRAINING REGION	4000	I16-013658	16-001768	06/24/2016	1	Invoice 4000, training for full time officer July 1, 2016 to June 30, 2017	010-7002-429100	\$ 3,150.00
	4000	I16-013658	16-001768	06/24/2016	2	Tri-River Police Training for police officers July 1, 2016 - June 30, 2017	010-0000-150000	\$ 3,150.00
[VENDOR] 2095 : DELTA DENTAL PLAN OF ILLINOIS	858901	I16-013745	16-000281	06/27/2016	1	Monthly Dental Expense - May	092-0000-453400	\$ 21,232.61
[VENDOR] 2244 : SIR SPEEDY PRINTING #6129	10414	I16-013308	16-001681	06/09/2016	1	Printing and folding of 300 residential notification letters for Maycliff project.	031-6001-460140	\$ 131.50
[VENDOR] 2352 : NORTHERN TOOL & EQUIPMENT CO.	35521913	I16-013843	16-001583	06/29/2016	1	Reference quote # 48735913, Item # 15782020, NS PW 4000psi 3.5 gp	283-4003-460180	\$ 1,299.99
	35521913	I16-013843	16-001583	06/29/2016	2	shipping	283-4003-460180	\$ 104.67
[VENDOR] 2452 : SECRETARY OF STATE	06/17/16	I16-013710	16-001801	06/27/2016	1	Title Application for New Unit 1459 2016 Ford 113 Explorer Police AWD 4DR Vin 1FM5K8AR9GGD31667	010-7002-484100	\$ 95.00
	06/17/16	I16-013710	16-001801	06/27/2016	2	Transfer of Registration Plate #P311963	010-7002-484100	\$ 25.00
	06/22/16	I16-013711	16-001824	06/27/2016	1	Transfer of License Plate # M100036 from 2008 Ford Crown Vic to 2008 Ford Explorer 4X4	010-7002-484100	\$ 25.00
	06/17/16	I16-013712	16-001802	06/27/2016	1	Title Applications for New 2016 113 Explorer Police AWD 4DR Units 1415, 1416, 1433, 1464 Vins Ending in D31664, D31665, D31668 and D31666	010-7002-484100	\$ 380.00
	06/17/16	I16-013712	16-001802	06/27/2016	2	Transfer of Registration #'s MP2482, MP12510, MP2485 and MP8775 - No Charge For MP Plates	010-7002-484100	\$ 0.00
[VENDOR] 2512 : MEADE, INC.	674459	I16-013739	16-000832	06/27/2016	1	Traffic signal maintenance to village owned signals - May	010-5002-443700	\$ 1,595.00
[VENDOR] 2673 : SPORTSFIELDS, INC.	216466	I16-013856	16-001646	06/29/2016	1	Baseball Infield Mix - #032-644302 for Centennial baseball fields	283-4003-462300	\$ 792.79
[VENDOR] 2780 : AIRY'S, INC.	21029	I16-013499	16-001649	06/14/2016	1	Emergency water main repair at Silver Lake Country Club Labor	031-6002-443800	\$ 5,298.41
	21029	I16-013499	16-001649	06/14/2016	2	Emergency water main repair at Silver Lake	031-6002-443800	\$ 1,606.31

Vendors	Vendor Invoice	Invoice	Purchase Order	Due Date	Line No	Line Item Description	Account Number	Amount
						Country Club Equipment		
[VENDOR] 2830 : CDW GOVERNMENT LLC	DGC0015	116-013746	16-001559	06/27/2016	1	Avaya 1151D1 - PoE injector - 20 Watt Mfg. Part: 700434897 CDW Part: 1282532	010-1600-441100	\$ 67.88
[VENDOR] 2842 : MID AMERICA TREE & LANDSCAPE, INC.	2891	116-013760	16-001536	06/28/2016	1	Nuisance mowing - 15546 Glen Lake Dr	010-2002-442210	\$ 100.00
	2892	116-013761	16-001536	06/28/2016	1	Nuisance mowing - 13601 85th Ave	010-2002-442210	\$ 80.00
	2890	116-013762	16-001536	06/28/2016	1	Nuisance mowing - 8560 Pine St	010-2002-442210	\$ 250.00
[VENDOR] 3037 : SERVICE SANITATION, INC.	7166105	116-013777	16-001470	06/28/2016	1	1 Standard Unit. To be delivered by 9:30am on May 31st (will be used on 5/31 beginning around 10a). Please contact Matt Creed, 825-4886 for placement at Brown Park (147th St. & Raney's Lane, Orland Park, IL 60462	283-4002-444550	\$ 57.00
	7171906	116-013795	16-000562	06/28/2016	1	Extra svc - Schussler Park	283-4003-444550	\$ 32.00
[VENDOR] 3132 : MOTIVE PARTS CO. - FMP	52-315812	116-013732	16-000184	06/27/2016	1	Battery core return	010-5006-461800	\$ -15.00
	52-315729	116-013733	16-000184	06/27/2016	1	TPS sensor	010-5006-461800	\$ 50.53
[VENDOR] 3348 : COLUMBIA PIPE & SUPPLY CO.	2054404	116-013573	16-001393	06/15/2016	1	2-1/2 CPVC S80 SXS 45 ELL 817-025C	283-4005-460180	\$ 37.64
[VENDOR] 3742 : JIM MELKA LANDSCAPING	4-194552	116-013894	16-000270	06/30/2016	1	Flowers/Shrubs - Parks	283-4003-463300	\$ 130.70
[VENDOR] 3878 : CUNNINGHAM RECREATION	PJI-0037745	116-013754	16-001478	06/28/2016	1	17247 Game time -Adaptive Swing Safety Belt \$111 less discount \$6.66 per quote# 112222	283-4003-461600	\$ 104.34
	PJI-0037745	116-013754	16-001478	06/28/2016	2	freight	283-4003-461600	\$ 19.10
[VENDOR] 4294 : METROPOLITAN FAMILY SERVICES/SOUTHWEST	01/31/16	116-013643	16-001813	06/24/2016	1	Crisis Intervention/Response Counseling - Police - January	010-1100-432600	\$ 2,500.00
	02/29/16	116-013644	16-001813	06/24/2016	1	Crisis Intervention/Response Counseling - Police - February	010-1100-432600	\$ 2,500.00
	03/31/16	116-013645	16-001813	06/24/2016	1	Crisis Intervention/Response Counseling - Police - March	010-1100-432600	\$ 2,500.00
	04/30/16	116-013646	16-001813	06/24/2016	1	Crisis Intervention/Response Counseling - Police - April	010-1100-432600	\$ 2,500.00
	05/31/16	116-013647	16-001813	06/24/2016	1	Crisis Intervention/Response Counseling - Police - May	010-1100-432600	\$ 2,500.00
[VENDOR] 4490 : ILLINOIS CITY/COUNTY MANAGEMENT	06/05/16	116-013521	16-001716	06/14/2016	1	Napoleon Haney - Membership in ILCMA (Illinois City/County Management Association 2016-2017	010-5001-429200	\$ 65.00
	06/05/16	116-013521	16-001716	06/14/2016	2	Ahmad Zayyad - Membership in ILCMA (Illinois City/County Management Association 2016-2017	031-6001-429200	\$ 140.00
[VENDOR] 4679 : CHRISTOPHER B. BURKE ENGINEERING, LTD.	128685	116-013617	15-003008	06/15/2016	1	Spring Creek Letter of Map Revision Project - 3/27-4/30/16	010-2004-432800	\$ 3,670.00
	128680	116-013618	16-000774	06/15/2016	1	CBBEL Monthly Retainer - April	010-2004-432500	\$ 6,500.00
	128680	116-013618	16-000774	06/15/2016	2	CBBEL Monthly Retainer - April	031-6001-432500	\$ 833.33
	128680	116-013618	16-000774	06/15/2016	3	CBBEL Monthly Retainer - April	031-6007-432500	\$ 1,166.67
	129660	116-013713	15-002857	06/27/2016	1	Phase II Engineering 151st Street Ravinia to West Ave - 3/27-5/28/16	054-0000-471250	\$ 13,406.57
	128962	116-013718		06/27/2016	1	R286 - GW Properties-159th & LaGrange - 5/1-5/12/16 - FINAL	010-0000-110903	\$ 357.14

Vendors	Vendor Invoice	Invoice	Purchase Order	Due Date	Line No	Line Item Description	Account Number	Amount
	128681	116-013719		06/27/2016	1	R293 - Community Honda - Offsite Storage - 3/27-4/30/16 - FINAL	010-0000-110903	\$ 909.06
[VENDOR] 4783 : CONNEY SAFETY PRODUCTS	05159647	116-013784	16-001640	06/28/2016	1	#81601 - Exam gloves (Medium)	283-4007-490440	\$ 36.32
	05159647	116-013784	16-001640	06/28/2016	2	#81602 - Exam gloves (Large)	283-4007-490440	\$ 54.48
	05159647	116-013784	16-001640	06/28/2016	3	#32404 - Antimicrobial hand wipes	283-4007-490440	\$ 48.96
[VENDOR] 5002 : SOUTHTOWN PAINT & WALLPAPER CO	001057720	116-013724	16-000579	06/27/2016	1	Painting supplies - SPLX	283-4007-461300	\$ 39.92
	001057697	116-013726	16-000259	06/27/2016	1	Paint - Parks	283-4003-461990	\$ 299.90
	001057944	116-013875	16-000579	06/30/2016	1	Paint - SPLX	283-4007-461300	\$ 59.98
[VENDOR] 5397 : PETTY CASH - DONNA RYMUT	6-23-16	116-013642		06/23/2016	1	Petty Cash Reimbursement - Business Travel	283-4001-429400	\$ 84.81
	6-23-16	116-013642		06/23/2016	2	Petty Cash Reimbursement - Donations	283-4001-484200	\$ 12.58
	6-23-16	116-013642		06/23/2016	3	Petty Cash Reimbursement - Domestic Supplies	283-4007-460150	\$ 103.22
	6-23-16	116-013642		06/23/2016	4	Petty Cash Reimbursement - Program Supplies/Kids Programs	283-4007-490400	\$ 59.72
	6-23-16	116-013642		06/23/2016	5	Petty Cash Reimbursement - Office Supplies	283-4007-461300	\$ 10.00
	6-23-16	116-013642		06/23/2016	6	Petty Cash Reimbursement-Program Supplies/Health Fair	283-4007-490400	\$ 74.23
	6-23-16	116-013642		06/23/2016	7	Petty Cash Reimbursement-Program Supplies/Senior Week & Colors Competition	283-4007-490400	\$ 30.93
[VENDOR] 5481 : ANIXTER INC.	227-114753	116-013640	16-001386	06/23/2016	1	CMP-00424CSP-7U-05 CS-UNIPRIS 6504+YELLOWCPK 23-4P UTP-CMP SOL BC CAT6 FEP/FRPVC YELLOW JKT BOX 1000FT Per Quote 04973	010-1600-460110	\$ 444.74
[VENDOR] 5644 : NEW LIFE SCREEN PRINTING & EMBROIDERY	24194	116-013704	16-001746	06/27/2016	1	Embroidered logos: "Village crest" ULC	283-4003-460190	\$ 60.00
	24194	116-013704	16-001746	06/27/2016	2	minimum order charge for printing	283-4003-460190	\$ 25.00
	24194	116-013704	16-001746	06/27/2016	3	Print only: "Village Crest" ULC Above Pockets	283-4003-460190	\$ 22.20
	24194	116-013704	16-001746	06/27/2016	4	Set up charge (re-order)	283-4003-460190	\$ 3.00
	24188	116-013874	16-001662	06/30/2016	1	Port Authority Ladies Polos White 1/s, 1/l, 2/xl "new Village Logo" ULC	283-4003-460190	\$ 72.00
	24188	116-013874	16-001662	06/30/2016	2	Port Authority Polos White 1/m, 4/l, 1/xl "New Village Logo" ULC	283-4003-460190	\$ 108.00
	24188	116-013874	16-001662	06/30/2016	3	Port Authority Polos white 2/xxl	283-4003-460190	\$ 40.00
	24188	116-013874	16-001662	06/30/2016	4	Flexfit Cap black	283-4003-460190	\$ 18.00
	24188	116-013874	16-001662	06/30/2016	5	Bayside Knit Cap Charcoal	283-4003-460190	\$ 12.00
	24188	116-013874	16-001662	06/30/2016	6	Digitizing/Design Charge	283-4003-460190	\$ 75.00
[VENDOR] 5744 : GATEWAY BUSINESS SYSTEMS, INC.	876047	116-013748	16-000550	06/27/2016	1	Konica Bizhub 222 in PW Command Room Copier ID #17350 Monthly fee per copy charge - May	031-6001-443600	\$ 24.58
	876050	116-013749	16-000167	06/27/2016	1	Copier maintenance for Finance South - May	031-1400-443600	\$ 1.52
[VENDOR] 5760 : GORDON FOOD SERVICE STORE	768121235	116-013888	16-001667	06/30/2016	1	Farmers' Market Initial Lunch Supplies	010-9450-464100	\$ 735.38
[VENDOR] 6862 : PARKREATION, INC.	5217	116-013903	16-001068	06/30/2016	1	12'x12'x8' high single post shade units by Shade Systems Inc. Turn n' slide easy fabric removal system on all 4 corners, Inground-direct bury post	283-4005-460180	\$ 26,964.00

Vendors	Vendor Invoice	Invoice	Purchase Order	Due Date	Line No	Line Item Description	Account Number	Amount
	5217	I16-013903	16-001068	06/30/2016	2	Discount	283-4005-460180	\$ -5,949.00
	5217	I16-013903	16-001068	06/30/2016	3	Custom Shade sail per attached drawing (10-13-15) consisting of (5) 10' columns and (1) 15' column and (5) shade sales. Direct bury - inground footings.	283-4005-460180	\$ 18,658.00
	5217	I16-013903	16-001068	06/30/2016	4	Engineering on Shade Unit (if needed)	283-4005-460180	\$ 900.00
	5217	I16-013903	16-001068	06/30/2016	5	Shipping on (9) SP12 and (1) custom shade sail	283-4005-460180	\$ 3,520.00
[VENDOR] 6879 : LIFEGUARD STORE INC.	INV425598	I16-013735	16-001574	06/27/2016	1	Adult flex life vests, yellow. 4 adult small sku #750YS, 4 adult medium, sku# 750YM; 4 adult large, sku# 750YL; 2 adult XL, sku #750YXL	283-4005-490500	\$ 377.00
	INV425598	I16-013735	16-001574	06/27/2016	2	Shipping	283-4005-490500	\$ 48.00
[VENDOR] 7138 : AUBIN	05/24/16	I16-013693	16-000484	06/27/2016	1	Plan Commissioner - Meeting Stipend - 5/24/16	010-8000-484990	\$ 75.00
[VENDOR] 7343 : CARQUEST AUTO PARTS STORES	2543-416848	I16-013720	16-000114	06/27/2016	1	Oil filters	010-5006-461700	\$ 3.86
	2543-417181	I16-013721	16-000114	06/27/2016	1	Threadlocker	010-5006-461990	\$ 21.15
	2543-416467	I16-013741	16-000114	06/27/2016	1	Oil	010-5006-462200	\$ 22.98
	2543-417616	I16-013878	16-000114	06/30/2016	1	Power window switch	010-5006-461800	\$ 68.39
	2543-417984	I16-013879	16-000114	06/30/2016	1	Control arm bushing	010-5006-461800	\$ 40.54
[VENDOR] 7537 : ALEXANDER EQUIPMENT CO., INC.	123636	I16-013576		06/15/2016	1	Return on original invoice 122577 - PO 16-1281	010-5006-461700	\$ -94.00
	123754	I16-013578		06/15/2016	1	Replacement for part returned on PO 16-1281	010-5006-461700	\$ 45.50
[VENDOR] 7592 : MUSIC THEATRE INTERNATIONAL	611343	I16-013708	16-001429	06/27/2016	1	Rights and Royalties for 2017 Performance of Beauty and the Beast. Show dates 3/23-3/26 2017. Contract C16-0053	283-0000-150000	\$ 4,390.00
[VENDOR] 7773 : LIFE FITNESS	4992022	I16-013516	16-000940	07/05/2016	1	Free weight equipment	283-4007-460180	\$ 14,575.16
	4994598	I16-013517	16-000940	07/05/2016	1	Free weight equipment	283-4007-460180	\$ 25,267.71
	4989205	I16-013895	16-000940	06/30/2016	1	Free weight equipment	283-4007-460180	\$ 17,784.08
[VENDOR] 8216 : ACE HARDWARE (HOMER GLEN)	53162/1	I16-013656	16-001732	06/24/2016	1	Swivel Hasp 3-1/4"	283-4005-461650	\$ 27.98
	53162/1	I16-013656	16-001732	06/24/2016	2	Goof Off Remover Voc Gal	283-4005-461650	\$ 21.99
	53120/1	I16-013788	16-000061	06/28/2016	1	Distilled water	010-5006-461990	\$ 11.94
	53128/1	I16-013858	16-000340	06/29/2016	1	Deck brushes - BM	010-1700-461300	\$ 16.98
	53128/1	I16-013858	16-000340	06/29/2016	2	Garden sprayer - BM	010-1700-460170	\$ 17.99
	53158/1	I16-013877	16-000340	06/30/2016	1	Fasteners - Building Maintenance	010-1700-461300	\$ 3.80
	53189/1	I16-013891	16-000246	06/30/2016	1	Rechargeable 9V batteries - Parks	283-4003-461990	\$ 116.91
[VENDOR] 8231 : APPLE CHEVROLET	300246	I16-013873	16-000160	06/30/2016	1	Trans dipstick	010-5006-461800	\$ 16.37
[VENDOR] 8393 : ILLINOIS AMERICAN WATER	1025-220004573984	I16-013872	16-000437	06/30/2016	1	Sewer Charges for Fernway Subdivision - 5/3-6/1/16	031-1400-441500	\$ 6,273.04
[VENDOR] 8534 : FORT DEARBORN LIFE	06/03/16	I16-013729	16-000506	06/14/2016	1	Monthly STD Claims Expense	092-0000-452805	\$ 5,119.16
[VENDOR] 8995 : STATE OF ILLINOIS	9557235	I16-013725	16-001630	06/27/2016	1	B0031547 - State Safety Inspection	283-4007-443100	\$ 70.00

Vendors	Vendor Invoice	Invoice	Purchase Order	Due Date	Line No	Line Item Description	Account Number	Amount
	9557235	116-013725	16-001630	06/27/2016	2	B0031549 State Safety Inspection	283-4007-443100	\$ 70.00
[VENDOR] 9042 : TINLEY GLASS CORPORATION	106	116-013886	16-000230	06/30/2016	1	Repairs - 153rd Metra	026-0000-443100	\$ 287.00
[VENDOR] 9192 : SPACECO, INC.	68381	116-013513	14-003192	07/05/2016	1	Jefferson Avenue Extension - 5/1-5/28/16	282-0000-432800	\$ 7,590.21
	67399	116-013537	13-000558	06/15/2016	1	Storm Sewer GIS Survey - 1/31-3/5/16	031-6007-470500	\$ 65,904.00
	67881	116-013538	13-000558	06/15/2016	1	Storm Sewer GIS Survey - 3/6-4/23/16	031-6007-432990	\$ 192.00
	67881	116-013538	13-000558	06/15/2016	2	Storm Sewer GIS Survey - 3/6-4/23/16	031-6007-432990	\$ 42,992.00
	67881	116-013538	13-000558	06/15/2016	3	Storm Sewer GIS Survey - 3/6-4/23/16	031-6007-470500	\$ 28,336.00
[VENDOR] 9238 : BURRIS EQUIPMENT	RS12435	116-013533	16-001699	07/05/2016	1	One(1) week rental of R07447 (Toro STX-38). June 06 thru June 10	010-5002-444500	\$ 1,000.00
[VENDOR] 9294 : MAP AUTOMOTIVE - CHICAGO	40-368101	116-013778	16-000154	06/28/2016	1	ABS harness	010-5006-461800	\$ 46.29
	40-367988	116-013779	16-000154	06/28/2016	1	Mini bulbs	010-5006-461800	\$ 41.40
	40-368291	116-013860	16-000154	06/29/2016	1	LP J Cases	010-5006-461800	\$ 18.30
[VENDOR] 9302 : POMP'S TIRE	690038921	116-013883	16-000124	06/30/2016	1	Tires	010-5006-461890	\$ 770.46
[VENDOR] 9449 : LABRAID, INC. FUNDRAISING	INV-15609	116-013722	16-001608	06/27/2016	1	Theatre Troupe Fundraiser - Shrek the Musical Butter Braids. 194 Total Sold. Profit is 40% of total. 13 items at \$22.20, 22 items at \$8.40, 159 items at \$7.80.	283-4002-490480	\$ 1,713.60
[VENDOR] 9489 : STARFISH AQUATICS INSTITUTE	12995	116-013673	16-001603	06/27/2016	1	Best Practices Lifeguard training manuals, 4th edition	283-4005-429100	\$ 349.50
	12995	116-013673	16-001603	06/27/2016	2	Shipping	283-4005-429100	\$ 25.90
[VENDOR] 9656 : MENARDS - HOMER GLEN	86243	116-013848	16-001625	06/29/2016	1	PVC Rain suit X-Large	283-4003-460190	\$ 90.93
	86243	116-013848	16-001625	06/29/2016	2	PVC Rain suite Large	283-4003-460190	\$ 38.97
	86405	116-013857	16-001023	06/29/2016	1	Ball valves	283-4003-461990	\$ 159.98
	96559	116-013862	16-000338	06/29/2016	1	Clamps - Humphrey scoreboard banner	283-4003-461990	\$ 15.20
	86550	116-013863	16-000338	06/29/2016	1	Supplies - Humphrey scoreboard banner	283-4003-461990	\$ 29.34
[VENDOR] 9664 : WAREHOUSE DIRECT	3079712-0	116-013443	16-001556	06/14/2016	1	Letr-trim Perf top 5x8" white pad WHD-8500/doz	031-6001-460100	\$ 5.39
	3079712-0	116-013443	16-001556	06/14/2016	2	Gregg Steno note pad 6x9" RED36-746	031-6001-460100	\$ 11.10
	3079712-0	116-013443	16-001556	06/14/2016	3	Post-It Capetown colors MMM654-5PK 3"x3"	031-6001-460100	\$ 19.84
	3079712-0	116-013443	16-001556	06/14/2016	4	Verbatim Store-n-go USB flash drive 4GB VER95236 (Bill C.)	031-6001-460100	\$ 59.70
	3079712-0	116-013443	16-001556	06/14/2016	5	Verbatim Pin Stripe USB flash drive 8GB VER49062 (Bill C)	031-6001-460100	\$ 72.00
	3079712-0	116-013443	16-001556	06/14/2016	6	Bunn Commercial Coffee Filters, 12 cup size 1000/carton BUN1M5002	010-5001-460150	\$ 12.01
	3079712-0	116-013443	16-001556	06/14/2016	7	Casio Tape Cassettes 12mm Black on White 2/pack CSOXR12WE2S	031-6001-460100	\$ 29.10
	3079712-0	116-013443	16-001556	06/14/2016	8	Swingline durable full strip desk stapler, black SW164601 (Lori)	031-6001-460100	\$ 18.33
	3079712-0	116-013443	16-001556	06/14/2016	9	Tops Memorandum Book 2-part carbonless TOP4150	031-6001-460100	\$ 112.90
	3079712-0	116-013443	16-001556	06/14/2016	10	Bic Wite Out EZ correction tape BICWOTAP10 10/box	031-6001-460100	\$ 15.19

Vendors	Vendor Invoice	Invoice	Purchase Order	Due Date	Line No	Line Item Description	Account Number	Amount
	3079946-0	I16-013444	16-000983	06/14/2016	1	Toilet paper/Cups/Dispenser hand towels - BM	010-1700-460150	\$ 465.56
	3078364-0	I16-013452	16-000983	06/14/2016	1	Coffee - VH lunchroom	010-1700-460150	\$ 76.44
	3075312-0	I16-013456	16-000983	06/14/2016	1	Disp. gloves - BM	010-1700-460150	\$ 69.90
	3082705-0	I16-013480	16-000983	06/14/2016	1	Stir sticks	010-1700-460150	\$ 5.34
	3082706-0	I16-013481	16-000983	06/14/2016	1	Kleenex/Napkins/Dish soap - BM	010-1700-460150	\$ 141.43
	3083758-0	I16-013723	16-000983	06/27/2016	1	Air freshener dispensers - BM	010-1700-460150	\$ 346.50
	3083407-0	I16-013737	16-001589	06/27/2016	1	UNV01117 Rubber Bands, Size 117, 7 x 1/ 8, 210 Bands/ 1lb Pack	010-2001-460100	\$ 5.36
	3083407-0	I16-013737	16-001589	06/27/2016	2	GMT6992 Caribou Coffee Caribou Blend, Medium Roast, K- cups, 24/ box	010-2001-460150	\$ 168.12
	3083402-0	I16-013738	16-001582	06/27/2016	1	Acrylic Clipboard: SAU21565	283-4005-460100	\$ 81.80
	3083402-0	I16-013738	16-001582	06/27/2016	2	Colored Sharpies: SAN22478	283-4005-460100	\$ 6.27
	3083402-0	I16-013738	16-001582	06/27/2016	3	Black Sharpie: SAN30001	283-4005-460100	\$ 7.20
	3083402-0	I16-013738	16-001582	06/27/2016	4	Heavyweight Industrial Poly Zip Bags: CLI47911	283-4005-460100	\$ 34.64
	3083402-0	I16-013738	16-001582	06/27/2016	5	clear vinyl shop ticket holder: CLI80911	283-4005-460100	\$ 30.92
	3083402-0	I16-013738	16-001582	06/27/2016	6	Horizontal Sign Holder: DEF69301	283-4001-460100	\$ 19.86
	3083402-0	I16-013738	16-001582	06/27/2016	7	Vertical Sign Holder: DEF69201	283-4001-460100	\$ 42.88
	3082144-1	I16-013743	16-000983	06/27/2016	1	Deep Woods repellent - CPAC	283-4005-461100	\$ 44.49
	3082712-1	I16-013759	16-001569	06/28/2016	1	#BLT-34734 - Oui Stacking Stool	283-4005-460180	\$ 479.32
	3086522-0	I16-013772	16-001598	06/28/2016	1	MOW-471608, red paper 8 1/2 x 11, 500 sheets/ream	031-1400-460100	\$ 24.00
	3086525-0	I16-013773	16-001599	06/28/2016	1	white copy paper (case): WHDSM11	283-4001-460100	\$ 179.70
	3086525-0	I16-013773	16-001599	06/28/2016	2	Rayovac C batteries-6: RAY-ALC12F	283-4001-460100	\$ 9.71
	3086645-0	I16-013774	16-000983	06/28/2016	1	Plates/Creamer/Forks/Knives/Can liners/Paper towels - BM	010-1700-460150	\$ 361.98
	3073353-1	I16-013841	16-000983	06/29/2016	1	Air freshener - BM	010-1700-460150	\$ 81.56
	3029724-0	I16-013889	16-001048	06/30/2016	1	WHDCOPY11 - 8 1/2 X 11 Copy paper	283-4003-460100	\$ 63.32
	3029724-0	I16-013889	16-001048	06/30/2016	2	DRN2070399 8 1/2 X 11 Refillable planner, black	283-4003-460100	\$ 33.37
	3029724-0	I16-013889	16-001048	06/30/2016	3	DRN491225 Two pages per day planning page refill 8 1/2 X 11, 2016	283-4003-460100	\$ 18.17
	3051906	I16-013890	16-001275	06/30/2016	1	UNV10048 Message Stamp, COPY, Pre-inked One- Color, Red	010-2001-460100	\$ 19.64
	3051906	I16-013890	16-001275	06/30/2016	2	COS035605 Pre- Inked Shutter Stamp with Microban, Red, SCANNED, 1 5/ 8 x 1/ 2	010-2001-443600	\$ 16.16
	2992884-0	I16-013893	16-001545	06/30/2016	1	Invoice #2992884-0 - Item #28010 - Blue Endtab Reinforced Legal Size Folders for HR.	010-1100-460100	\$ 51.48
	3089163-0	I16-013898	16-000983	06/30/2016	1	Spoons/Napkins/Cups - BM	010-1700-460150	\$ 155.28
	3089566-0	I16-013900	16-001638	06/30/2016	1	#DRI-351R1 - Smart Money Pen (counterfeit detector pen)	283-4007-460100	\$ 21.32
	3089557-0	I16-013901	16-001618	06/30/2016	1	#HEWCZ181A - HP Laser Jet Printer	283-4005-460180	\$ 266.77
	3089487-0	I16-013905	16-001617	06/30/2016	1	#MMM-1426 - Packing Tape	283-4007-460100	\$ 10.93
	3089487-0	I16-013905	16-001617	06/30/2016	2	#PFX-415213 - Letter Size Hanging File Folders	283-4007-460100	\$ 33.08
	3089487-0	I16-013905	16-001617	06/30/2016	3	#UNV-12113 - Letter Size File Folders	283-4007-460100	\$ 12.78
	3089487-0	I16-013905	16-001617	06/30/2016	4	#RAY-ALD12F - Batteries (D size)	283-4007-461300	\$ 23.60
[VENDOR] 9765 : LANGUAGE IN ACTION, INC.	06/03/16	I16-013792	16-000308	06/28/2016	1	Spanish Language Classes - 4/25-5/23/16	283-4002-490200	\$ 285.00
[VENDOR] 9792 : TOTAL BUILDING SERVICE, INC.	0045562-IN	I16-013652	16-001835	06/24/2016	1	Cleaning CAC Lobby, Commons, Restrooms & Exhibit Hall on 5/21/16	283-4001-442930	\$ 80.00

Vendors	Vendor Invoice	Invoice	Purchase Order	Due Date	Line No	Line Item Description	Account Number	Amount
	0045611-IN	I16-013755	16-000295	06/28/2016	1	Village Hall - June	010-1700-442930	\$ 4,104.81
	0045611-IN	I16-013755	16-000295	06/28/2016	2	RDC	283-4001-442930	\$ 1,183.99
	0045611-IN	I16-013755	16-000295	06/28/2016	3	OVH	010-1700-442930	\$ 264.20
	0045611-IN	I16-013755	16-000295	06/28/2016	4	GBC	010-1700-442930	\$ 267.20
	0045611-IN	I16-013755	16-000295	06/28/2016	5	FLC	283-4001-442930	\$ 3,752.55
	0045611-IN	I16-013755	16-000295	06/28/2016	6	PD	010-1700-442930	\$ 5,660.11
	0045611-IN	I16-013755	16-000295	06/28/2016	7	PW	010-1700-442930	\$ 1,144.85
	0045611-IN	I16-013755	16-000295	06/28/2016	8	BM shop (formerly ESDA)	010-1700-442930	\$ 53.82
	0045611-IN	I16-013755	16-000295	06/28/2016	9	CAC	283-4001-442930	\$ 993.18
	0045611-IN	I16-013755	16-000295	06/28/2016	10	143rd Metra	026-0000-442930	\$ 396.29
	0045611-IN	I16-013755	16-000295	06/28/2016	11	153rd Metra	026-0000-442930	\$ 264.20
	0045611-IN	I16-013755	16-000295	06/28/2016	12	179th Metra	026-0000-442930	\$ 264.20
	0045611-IN	I16-013755	16-000295	06/28/2016	13	Learning Ally	010-1700-442930	\$ 283.77
	0045611-IN	I16-013755	16-000295	06/28/2016	14	Rec. Admin.	283-4001-442930	\$ 689.84
	0045611-IN	I16-013755	16-000295	06/28/2016	15	Parks Office	010-1700-442930	\$ 161.45
	0045611-IN	I16-013755	16-000295	06/28/2016	16	SPLX (summer)	283-4007-442930	\$ 9,701.83
	0045611-IN	I16-013755	16-000295	06/28/2016	17	Civic Center	021-1800-442930	\$ 1,450.00
[VENDOR] 9826 : CHOTT PIANO SERVICE	05/20/16	I16-013379	16-001114	06/13/2016	1	Piano Tuning of Concert Grand Piano on 5/20/2016	010-9450-442990	\$ 110.00
[VENDOR] 9938 : SMITH DAWSON & ANDREWS	1008303	I16-013756	16-000442	06/28/2016	1	Professional services - June	010-0000-432850	\$ 3,333.33
[VENDOR] 10056 : LOWE'S COMPANIES, INC.	02160	I16-013657	16-001727	06/24/2016	1	DW 3/8-IN INDUSTRIAL COBA	283-4003-460170	\$ 11.68
	02160	I16-013657	16-001727	06/24/2016	2	3/8-INX8-IN ZINC EYE BOLT	283-4003-461990	\$ 4.60
	02160	I16-013657	16-001727	06/24/2016	3	25-CT 3/8-IN ZINC FLAT	283-4003-461990	\$ 0.85
	02160	I16-013657	16-001727	06/24/2016	4	DW 3/8-INX6-IN BLK OXIDE	283-4003-460170	\$ 14.34
	02523	I16-013694	16-000257	06/27/2016	1	Remesh/Lumber/Conduit/PVC caps - CPAC	283-4005-461650	\$ 193.69
	02429	I16-013695	16-001004	06/27/2016	1	Brita water faucet/Epoxy/Sharpies - RA Plaque screws - Cent. Pk.	010-1700-461300	\$ 35.27
	02429	I16-013695	16-001004	06/27/2016	2	Putty knife	010-1700-460170	\$ 6.46
	02205	I16-013789	16-001004	06/28/2016	1	Caulk - RDC	010-1700-461300	\$ 40.38
	02113	I16-013790	16-001004	06/28/2016	1	Double-sided tape/WD-40	010-1700-461300	\$ 17.05
	02982	I16-013842	16-000766	06/29/2016	1	Building Materials for Sets and Flats for OPTT	283-4002-490450	\$ 19.42
	02829	I16-013849	16-001020	06/29/2016	1	Building supplies - Metra sign repairs	026-0000-461300	\$ 7.77
	01565	I16-013880	16-001022	06/30/2016	1	Bolts - Parks	283-4003-461990	\$ 65.88
	02270	I16-013881	16-001022	06/30/2016	1	Lysol spray - Parks	283-4003-461990	\$ 45.48
	02223	I16-013882	16-001004	06/30/2016	1	PVC pipe/Cement - CAC	010-1700-461300	\$ 22.77
	02330	I16-013892	16-001020	06/30/2016	1	Coupling/Connectors - CPAC	283-4005-461300	\$ 44.04
[VENDOR] 10201 : COSTCO WHOLESALE	016719	I16-013851	16-001664	06/29/2016	1	Replenish water for office meetings.	010-1100-460150	\$ 6.78
	016719	I16-013851	16-001664	06/29/2016	2	Replenish coffee for office meetings	010-1100-460150	\$ 33.98
[VENDOR] 10213 : CURRIE MOTORS	101811	I16-013852	16-000179	06/29/2016	1	Trans pan gasket	010-5006-461800	\$ 34.78
	101832	I16-013853	16-000179	06/29/2016	1	Gasket	010-5006-461800	\$ 25.42
	101810	I16-013854	16-000179	06/29/2016	1	Head rest sleeves	010-5006-461800	\$ 16.78
	101841	I16-013855	16-000179	06/29/2016	1	Moulding	010-5006-461800	\$ 186.02

Vendors	Vendor Invoice	Invoice	Purchase Order	Due Date	Line No	Line Item Description	Account Number	Amount
[VENDOR] 10401 : SCARIANO, HIMES AND PETRARCA	38017	I16-013736	16-001686	06/27/2016	1	Invoice No. 38017, Professional services for Vehicle Ticket hearing 5/5/16	010-0000-432100	\$ 370.50
	38017	I16-013736	16-001686	06/27/2016	2	cost allowance	010-0000-432100	\$ 18.53
[VENDOR] 10592 : NEXT DAY PLUS	5000617	I16-013348	16-000539	06/13/2016	1	PW Office copier (MXBCG4917F) Black & White/Color usage - April	031-6001-443600	\$ 199.33
	5000617	I16-013348	16-000539	06/13/2016	2	V & E(CNF8G2W8TP) and PW Parts(CNF8G35GMS) black & white copiers usage - April	010-5001-443600	\$ 8.45
	5002816	I16-013764	16-000800	06/28/2016	1	Monthly copier usage and maintenance fees for both the Administration and Lobby copiers - May	010-1100-443600	\$ 339.83
	5002818	I16-013765	16-000669	06/28/2016	1	MFP Copier, 2016 Maintenance Agreement - May	010-2001-443600	\$ 558.53
	5002819	I16-013766	16-000206	06/28/2016	1	Copier Maintenance - May	010-1200-443600	\$ 131.69
	5002821	I16-013767	16-000725	06/28/2016	1	Copier Maintenance Costs - May	283-4007-443600	\$ 260.03
	5002820	I16-013768	16-000926	06/28/2016	1	2016 Xerox C-70 copier charges at \$0.006 per B/W page; \$0.055 per color page - May	283-4001-443600	\$ 1,058.19
[VENDOR] 10885 : GARCIA	garcia 5-28-16	I16-013615		06/15/2016	1	Translation services for battery invest. 2016-75615	010-7002-432990	\$ 90.00
[VENDOR] 11069 : UNITED GYMNASTICS ACADEMY	06/10/16	I16-013922	16-000211	07/01/2016	1	Gymnastics Classes 4/25-6/20/16	283-4007-490200	\$ 10,638.50
[VENDOR] 11147 : EIS/ELEVATOR INSPECTION SERVICES, INC	60636	I16-013859	16-001231	06/29/2016	1	Elevator Inspection Services - Orland Funeral home	010-2002-432930	\$ 80.00
[VENDOR] 11424 : AT & T	831-000-2478 678	I16-013731		06/27/2016	1	Internet svcs	010-1600-442850	\$ 1,856.96
[VENDOR] 11488 : G & K SERVICES, INC.	1028357199	I16-013847	16-000077	06/29/2016	1	Shop rag service	010-5006-442700	\$ 71.18
[VENDOR] 11505 : PETTY CASH - JOHN KEATING	J. keating 6-10-16	I16-013523		06/14/2016	1	Confidential Funds May 2016	010-7002-432700	\$ 510.00
[VENDOR] 11519 : DUNBAR ARMORED	3793086	I16-013793	16-000177	06/28/2016	1	Armored transport for Finance.	010-1400-442900	\$ 67.94
	3793086	I16-013793	16-000177	06/28/2016	2	Armored transport for Water Billing.	031-1400-442900	\$ 67.94
	3793086	I16-013793	16-000177	06/28/2016	3	Armored transport for Recreation.	283-4001-442900	\$ 67.93
	3793086	I16-013793	16-000177	06/28/2016	4	Armored transport for Centennial Pool.	283-4005-442900	\$ 434.13
	3793086	I16-013793	16-000177	06/28/2016	5	Armored transport for Sportsplex.	283-4007-442900	\$ 227.81
[VENDOR] 11645 : E. COONEY ASSOCIATES, INC.	201613-04	I16-013692	16-001755	06/27/2016	1	Technical Support - Triangle Construction Project	282-0000-432800	\$ 4,357.13
[VENDOR] 11685 : CHEAP KEYS LOCKSMITH	29527	I16-013845	16-001719	06/29/2016	1	master key 6 doors main building	010-1700-443100	\$ 180.00
	29527	I16-013845	16-001719	06/29/2016	2	Master Key 4 locks garage doors	010-1700-443100	\$ 120.00
	29527	I16-013845	16-001719	06/29/2016	3	Keys Stamped	010-1700-443100	\$ 170.00
	29527	I16-013845	16-001719	06/29/2016	4	Service charge	010-1700-443100	\$ 60.00
	29585	I16-013846	16-001831	06/29/2016	1	Service Charge	283-4005-443100	\$ 50.00
	29585	I16-013846	16-001831	06/29/2016	2	Marks Locks	283-4005-443100	\$ 260.00
	29585	I16-013846	16-001831	06/29/2016	3	Install doors	283-4005-443100	\$ 60.00
	29585	I16-013846	16-001831	06/29/2016	4	Shipping	283-4005-443100	\$ 75.00
	29585	I16-013846	16-001831	06/29/2016	5	Prime Keys	283-4005-443100	\$ 125.00

Vendors	Vendor Invoice	Invoice	Purchase Order	Due Date	Line No	Line Item Description	Account Number	Amount
[VENDOR] 11697 : G.A.C. ENTERTAINMENT	147008	I16-011820	16-001145	07/05/2016	1	DJ for Wacky Wednesday July 13, 2016 11am-1pm FLC Ampitheater	010-9450-442990	\$ 200.00
	147004	I16-013529	16-001641	07/05/2016	1	entertainment DJ for Fun in the Park, July 19, Country Club Estates	010-9450-442990	\$ 200.00
[VENDOR] 11856 : ARCHER WINDOW CLEANING	1799	I16-013659	16-000161	06/24/2016	1	Village Hall	010-1700-442920	\$ 1,400.00
	1799	I16-013659	16-000161	06/24/2016	2	PD	010-1700-442920	\$ 275.00
	1799	I16-013659	16-000161	06/24/2016	3	PW	010-1700-442920	\$ 175.00
	1799	I16-013659	16-000161	06/24/2016	4	Civic Center	021-1800-442920	\$ 250.00
	1799	I16-013659	16-000161	06/24/2016	5	SPLX	283-4007-442920	\$ 1,800.00
	1799	I16-013659	16-000161	06/24/2016	6	Rec Admin.	283-4001-442920	\$ 250.00
	1799	I16-013659	16-000161	06/24/2016	7	RDC	283-4001-442920	\$ 30.00
	1799	I16-013659	16-000161	06/24/2016	8	FLC	283-4001-442920	\$ 300.00
	1799	I16-013659	16-000161	06/24/2016	9	CAC	283-4001-442920	\$ 350.00
	1799	I16-013659	16-000161	06/24/2016	10	OVH	010-1700-442920	\$ 190.00
	1799	I16-013659	16-000161	06/24/2016	11	Metra	026-0000-442920	\$ 120.00
[VENDOR] 9604 : SIEVERT ELECTRIC	S44005	I16-013757	16-001083	06/28/2016	1	Electromechanical football scoreboard (per full bid specifications)	283-4003-470300	\$ 8,185.00
	S44005	I16-013757	16-001083	06/28/2016	2	Wireless controller with all included hardware	283-4003-470300	\$ 980.00
	S44005	I16-013757	16-001083	06/28/2016	3	Electronic Team Name (ETN)	283-4003-470300	\$ 2,380.00
	S44005	I16-013757	16-001083	06/28/2016	4	Delivery charges	283-4003-470300	\$ 600.00
[VENDOR] 12288 : MACCARB, INC.	0204-002423	I16-013611	16-000586	06/15/2016	1	CO2 for CPAC water treatment	283-4005-462500	\$ 514.08
	0202-020358	I16-013839	16-000586	06/29/2016	1	CO2 for CPAC water treatment	283-4005-462500	\$ 412.60
	0202-020389	I16-013899	16-000586	06/30/2016	1	CO2 for CPAC water treatment	283-4005-462500	\$ 293.13
[VENDOR] 12337 : KEVRON PRINTING & MAILING, INC.	16-34076	I16-013651	16-001252	06/24/2016	1	Printing of 3' X 5' banner with for senior event at cultural center	010-1500-460140	\$ 110.00
[VENDOR] 12374 : FLOOD TESTING LABORATORIES	16-040002-E	I16-013648	16-000938	06/24/2016	1	Downtown Main Street Parking Deck - Material Testing Services through 3/31/16	282-0000-471250	\$ 21,942.55
[VENDOR] 12381 : EYELIGHT STUDIOS, LLC	VOP-110	I16-013902	16-001679	06/30/2016	1	Enjoy Orland Park broadcast version, FCPX HD	010-1201-432250	\$ 50.00
[VENDOR] 12474 : D CONSTRUCTION	3	I16-013610	16-001446	07/05/2016	1	2016 Neighborhood Road Improvement Program through 6/2/16	054-0000-471250	\$ 581,572.94
	3	I16-013610	16-001446	07/05/2016	2	Retainage for Pays 1,2,3	054-0000-205000	\$ -107,477.76
[VENDOR] 12483 : SCHAAF EQUIPMENT COMPANY	1000046373	I16-013775	16-000090	06/28/2016	1	Shear pins	010-5006-461700	\$ 44.92
[VENDOR] 12496 : PRECISE MOBILE RESOURCE MANAGEMENT	IN200-1008724	I16-013528	16-000156	06/14/2016	1	Pooled data - April	010-5003-442850	\$ 13.21
	IN200-1008724	I16-013528	16-000156	06/14/2016	1	Pooled data - April	010-5006-442850	\$ 258.08
	IN200-1008724	I16-013528	16-000156	06/14/2016	1	Pooled data - April	031-6001-442850	\$ 75.55
	IN200-1008826	I16-013744	16-001109	06/27/2016	1	Shipping cost for AVL device change overs	010-5006-441600	\$ 25.07
[VENDOR] 12628 : LANER MUCHIN, LTD	491179	I16-013912	16-001781	06/30/2016	1	Legal Services - Audit Letter Response	010-0000-432100	\$ 62.50
[VENDOR] 12635 : CHICAGO PARTS & SOUND	763216	I16-013838	16-000118	06/29/2016	1	Wiper blades/Screens	010-5006-461800	\$ 117.60

Vendors	Vendor Invoice	Invoice	Purchase Order	Due Date	Line No	Line Item Description	Account Number	Amount
[VENDOR] 12725 : BAXTER & WOODMAN, INC.	0185439	I16-011957	15-003354	04/26/2016	1	Fernway Roadway & Ditch Grading Engineering through 4/16/16	054-0000-471250	\$ 2,032.50
	0185967	I16-012519	15-003354	06/19/2016	1	2015 Fernway Roadway & Ditch Grading Engineering through 5/14/16	054-0000-471250	\$ 1,645.00
[VENDOR] 12736 : MINERAL MASTERS	00037255	I16-013783	16-000588	06/28/2016	1	\$1.16 per gallon sodium hypochlorite - delivered	283-4005-462500	\$ 1,160.00
[VENDOR] 12737 : ORIGINAL WATERMEN, INC.	38025	I16-013782	16-001195	06/28/2016	1	Guard Durafast Corsscutfit #TGUL - Navy. 15 - 28'S, 25 - 30'S, 48 - 32'S, 30 - 34'S, 10 - 36'S	283-4005-460190	\$ 85.50
	38025	I16-013782	16-001195	06/28/2016	2	Freight	283-4005-460190	\$ 8.27
[VENDOR] 12792 : UPBEAT SITE FURNISHINGS	578071	I16-013727	16-001364	06/27/2016	1	#F1308 Square Expanded Steel 3-Seat ADA Table, surface mount. Blue seat & top; black frame	283-4005-460180	\$ 790.00
	578071	I16-013727	16-001364	06/27/2016	2	Shipping	283-4005-460180	\$ 101.15
[VENDOR] 12843 : AMERICAN LEAK DETECTION	5313	I16-013703	16-001747	06/27/2016	1	Leak Detection on activity pool. Leak found on suction line of slide.	283-4005-443200	\$ 2,000.00
[VENDOR] 12892 : BATTERY GIANT	12182	I16-013580	16-000213	06/15/2016	1	Batteries for BM	010-1700-461300	\$ 30.40
[VENDOR] 13010 : CPR CELL PHONE REPAIR	VOP-2016-06	I16-013868		06/30/2016	1	Replace LCD screen - 1/7/16 - Hackett. Invoice never sent	010-7002-460180	\$ 103.49
[VENDOR] 13139 : FIRST ADVANTAGE LNS OCC. HEALTH SOLUTIONS, INC.	2533201605	I16-013653	16-000765	06/24/2016	1	Pre-Employment Drug Screens	010-1100-429510	\$ 5,085.00
	2533201605	I16-013653	16-000765	06/24/2016	2	Employee Drug Screens	010-1100-429500	\$ 350.00
[VENDOR] 13140 : V3 CONSTRUCTION GROUP, LTD	7	I16-012780	15-001312	05/27/2016	1	Stewardship Management of Imperial Lane Pond through 4/30/16	031-6007-443500	\$ 1,800.00
	7	I16-012780	15-001312	05/27/2016	2	Stewardship Management of Village Hall North Pond through 4/30/16	031-6007-443500	\$ 4,525.00
	7	I16-012780	15-001312	05/27/2016	3	Stewardship Management of Village Hall South Pond through 4/30/16	031-6007-443500	\$ 5,905.00
	19	I16-013620	14-000968	06/15/2016	1	LaGrange Road Corridor Enhancements from 179th to 131st - Construction Management through 5/31/16	054-0000-484800	\$ 566,763.03
[VENDOR] 13217 : INTEGRATED LAKES MANAGEMENT, INC.	26485	I16-013742	16-001223	06/27/2016	1	Aquatic weed and algae control at Marley Middle pond	031-6007-442210	\$ 215.82
[VENDOR] 13247 : JACKSON LEWIS P.C.	6748263	I16-013910	16-001855	06/30/2016	1	Legal Services - General	010-0000-432100	\$ 450.00
	6738984	I16-013911	16-001818	06/30/2016	1	Legal Services - MAP Contracts Grievance 2015-03	010-0000-432100	\$ 6,460.90
[VENDOR] 13394 : INTEGRITY FITNESS	8663	I16-013908	16-000563	06/30/2016	1	Sportsplex Equipment Repair and Maintenance	283-4007-443200	\$ 295.00
[VENDOR] 13481 : KONE INC.	949305531	I16-013794	16-000505	06/28/2016	1	Monthly elevator maintenance for CAC - June	283-4001-442910	\$ 155.18
	949305531	I16-013794	16-000505	06/28/2016	2	Monthly elevator maintenance for FLC - June	283-4001-442910	\$ 155.18
	949305531	I16-013794	16-000505	06/28/2016	3	Monthly elevator maintenance for VH - June	010-1700-442910	\$ 155.18

Vendors	Vendor Invoice	Invoice	Purchase Order	Due Date	Line No	Line Item Description	Account Number	Amount
[VENDOR] 13494 : PALOS MEDICAL GROUP, LLC	OR01	I16-013702	16-001762	06/27/2016	1	Schoonveld, Rosinski, Walsh, billing date 5/31/16	010-7002-429500	\$ 765.00
[VENDOR] 13541 : KANTOR	05/31/16	I16-013740	16-000048	06/27/2016	1	5/24/16 Magic class	283-4002-490200	\$ 154.00
[VENDOR] 13566 : CHICAGO TRIBUNE MEDIA GROUP	002733999	I16-013728	16-001535	06/27/2016	1	RFQ 16-020 Holiday Lighting 5/23/16 #4203078	010-1100-442300	\$ 94.49
	002733999	I16-013728	16-001535	06/27/2016	2	ITB 16-021 Orlan Brook Drive Culvert Replacement Legal Ad 5/31/16 (#4216507)	031-6001-442300	\$ 112.42
[VENDOR] 13646 : RUETTIGER, TONELLI& ASSOCIATES, INC.	0000231	I16-011243	15-001886	04/07/2016	1	Mobile GIS Application - 1/31-2/27/16	031-6001-460130	\$ 2,837.50
	0000231	I16-011243	15-001886	04/07/2016	2	Mobile GIS Application - 1/31-2/27/16	010-1600-460130	\$ 1,418.75
	0000530	I16-012783	15-001886	05/27/2016	1	Mobile GIS Application - 4/3-4/30/16	031-6001-460130	\$ 303.80
[VENDOR] 13720 : DYNEGY ENERGY SERVICES	0732010007	I16-013665		06/24/2016	1	2/26-3/24/16	010-5002-441300	\$ 139.25
	0763098102	I16-013666		06/24/2016	1	2/26-3/24/16	010-5002-441300	\$ 172.27
	1010090017	I16-013667		06/24/2016	1	3/1-3/29/16	010-5002-441300	\$ 6,876.19
	4737017028	I16-013668		06/27/2016	1	2/25-3/27/16	010-5002-441300	\$ 666.32
	0732010007	I16-013675		06/27/2016	1	3/25-4/24/16	010-5002-441300	\$ 164.85
	0763098102	I16-013676		06/27/2016	1	3/25-4/24/16	010-5002-441300	\$ 169.58
	1010090017	I16-013677		06/27/2016	1	3/30-4/27/16	010-5002-441300	\$ 6,231.29
	4737017028	I16-013678		06/27/2016	1	3/28-4/25/16	010-5002-441300	\$ 527.59
[VENDOR] 13884 : ONE UP SIGNS, LLC	2016-12476	I16-013471	16-001592	06/14/2016	1	Color: Matte Black, lettering for (1) Office Plaque - Add lettering to existing office sign, Text: Michael Coleman, Building Division Manager	010-1700-461500	\$ 20.00
	2016-12507	I16-013785	16-001639	06/28/2016	1	5' x 3' banner for Independence Day (artwork provided)	010-9450-460140	\$ 75.00
[VENDOR] 13918 : MARTIN	BSE-52687	I16-011979	16-000721	07/05/2016	1	Fun in the Park Performance per attached contract.	010-9450-442990	\$ 500.00
[VENDOR] 2222223.52239 : JAIME MCCRACKEN	27143020181070	I16-006306		03/14/2016	1	Property Tax Rebate	281-0000-484500	\$ 43.44
[VENDOR] 13938 : GLOVER & ASSOCIATES	04/25/16	I16-013909	16-001774	06/30/2016	1	Myers-Briggs Workshops held March 30th and April 25th.	010-0000-429100	\$ 4,900.00
[VENDOR] 13941 : MCMANUS	04/11/16	I16-013641	16-000976	06/23/2016	1	Fitness for Duty Exam and Follow-up	010-1100-429500	\$ 1,500.00
[VENDOR] 13966 : DAVE RUDOLPH, INC	BSE-53717	I16-013923	16-001255	07/01/2016	1	child entertainer for Wacky Wednesday event July 13, 2016 11am-11:45am FLC Amphitheater	010-9450-442990	\$ 500.00
[VENDOR] 13973 : DAHLMAN SHEET METAL CO.	13827	I16-013458	16-001296	06/14/2016	1	Set of 18ga welded equipment supports Supply and return transition fittings 1' internal liner for fittings	010-1700-443100	\$ 2,382.00
[VENDOR] 13978 : MIDWEST ENTERTAINERS INC.	03/15/16	I16-012980	16-001590	07/05/2016	1	Entertainment for Concert In The Park, Sunday, July 17, 2016 from 6pm-7:30pm at Crescent Park	010-9450-442990	\$ 1,800.00

Vendors	Vendor Invoice	Invoice	Purchase Order	Due Date	Line No	Line Item Description	Account Number	Amount
[VENDOR] 13982 : COVE REMEDIATION	15-20600	116-013353	16-001298	06/13/2016	1	Removal of approximately 120 square ft. of asbestos's floor tile.	031-6007-470500	\$ 2,870.00
[VENDOR] 14018 : SC RESTORATION	1604001	116-013734	16-001527	06/27/2016	1	Prep concrete cracks per Christopher B. Burke drawings and pressure inject cracks per manufacture recommendation on 3 Meter diving platform per proposal 16018	283-4005-443150	\$ 4,265.00
[VENDOR] 3333333.1603 : ALLEN LYNCH FOUNDATION	6122016	116-013572		06/15/2016	1	donation	010-1500-484200	\$ 250.00
[VENDOR] 3333333.1607 : ANDRILL HATCH-SMALL	Hatch-Small 5-28-16	116-013614		06/15/2016	1	Overpayment on citation P325408, P323809, P310821	010-0000-372250	\$ 5.00
[VENDOR] 3333333.1608 : FATTIES PUB	BL-16-18292	116-013621		06/16/2016	1	Business paid for 8 amusement devices at \$50 each but has 4. Refunding 4 payments of \$50.	010-0000-321600	\$ 200.00
[VENDOR] 3333333.1609 : DIANA LAGUNAS	06182016	116-013623		06/17/2016	1	Lagunas - 04/23/2016 \$200 Security Deposit Refund.	021-0000-373900	\$ 200.00
[VENDOR] 3333333.1610 : MICHELLE MIRANDA	Mianda 6-20-16	116-013625		06/21/2016	1	Overpayment on citation P328402	010-0000-372250	\$ 100.00
[VENDOR] 3333333.1611 : CHRISTINE A. WESTPHAL	06/21/2016	116-013626		06/21/2016	1	Maycliff subdivision Stormwater Improvement Easement 8601 w. 143rd Place	031-6007-470500	\$ 3,300.00
[VENDOR] 3333333.1612 : LOVIN' TAILS	06/14/16	116-013627		06/21/2016	1	Farmers' Market refund - prospective company not accepted as vendor	010-0000-348410	\$ 150.00
[VENDOR] 3333333.1613 : ROGER BRADSHAW	06/21/2016	116-013628		06/21/2016	1	Maycliff subdivision Stormwater Improvement Easement 8557 W. 143rd Place	031-6007-470500	\$ 3,300.00
[VENDOR] 3333333.1614 : BECKY DELLE	06212016	116-013629		06/22/2016	1	Delle 06/10/2016 \$200 Security Refund Deposit	021-0000-373900	\$ 200.00
[VENDOR] 3333333.1615 : VERONICA MANN	06212016	116-013630		06/22/2016	1	Mann 06/11/2016 \$200 Security Refund Deposit	021-0000-373900	\$ 200.00
[VENDOR] 3333333.1616 : MICHELLE ROGERS	06212016	116-013631		06/22/2016	1	Rogers 06/11/2016 \$200 Security Deposit Refund	021-0000-373900	\$ 200.00
[VENDOR] 3333333.1617 : KAREN URIBE	06212016	116-013632		06/22/2016	1	Uribe 06/12/2016 \$200 Security Refund Deposit	021-0000-373900	\$ 200.00
[VENDOR] 3333333.1618 : QUADALUPE ROJAS	06212016	116-013633		06/22/2016	1	Rojas 06/18/2016 \$255 Refund = \$200 Security Deposit Refund + \$55 Room Refund	021-0000-373900	\$ 255.00
[VENDOR] 3333333.1619 : ARTHUR GARCIA	06212016	116-013634		06/22/2016	1	Garcia 06/17/2016 \$300 Security Deposit Refund	021-0000-373900	\$ 300.00
[VENDOR] 3333333.1620 : CAROLYN WILLIAMS	06212016	116-013635		06/22/2016	1	Williams 06/17/2016 \$200 Security Deposit Refund	021-0000-373900	\$ 200.00
[VENDOR] 3333333.1623 : MOHAMMED ALLAN	06212016	116-013637		06/22/2016	1	Allan 06/19/2016 \$200 Security Deposit Refund	021-0000-373900	\$ 200.00

Vendors	Vendor Invoice	Invoice	Purchase Order	Due Date	Line No	Line Item Description	Account Number	Amount
[VENDOR] 3333333.1624 : BEVERLY LARUE	06212016	I16-013638		06/22/2016	1	LaRue 06/19/2016 \$200 Security Deposit Refund	021-0000-373900	\$ 200.00
[VENDOR] 3333333.1625 : FOUR SEASONS HEATING & AIR	BP-16-01533	I16-013639		06/23/2016	1	Duplicate permit for 24 Prairie Ln	010-0000-323450	\$ 45.00
[VENDOR] 12599.338 : KELLY D WIRTZ	CD-000304	I16-013654		06/24/2016	1	Refund	010-0000-321200	\$ 30.00
[VENDOR] 9999999.196 : WESCOM CREDIT UNION	62716	I16-013674		06/27/2016	1	To refund payee-payment was sent to VOP in error through water billing lockbox	031-0000-229100	\$ 57.38
GRAND TOTAL :							\$	2,027,530.95

**Village of Orland Park
Open Item Listing**

Run Date: 07/01/2016 User: bobrien

Status: POSTED Due Date: 07/01/2016
Bank Account: BMO Harris Bank-Vendor Disbursement
Invoice Type: Payroll Created By: All

Vendors	Vendor Invoice	Invoice	Purchase Order	Due Date	Line No	Line Item Description	Account Number	Amount
[VENDOR] 3929 : ICMA RETIREMENT TRUST - 457	07/01/2016	116-013804		07/01/2016	1	ICMA Payment 7/1/16	010-0000-210125	\$ 1,804.85
[VENDOR] 3931 : USCM CLEARING ACCOUNT	07/01/2016	116-013805		07/01/2016	1	Nationwide Payment 7/1/16	010-0000-210126	\$ 7,268.08
[VENDOR] 5974 : ORLAND PARK POLICE SUPERVISORS ASSOC.	07/01/2016	116-013807		07/01/2016	1		010-0000-210109	\$ 190.00
[VENDOR] 8534 : FORT DEARBORN LIFE	20160617	116-013624		06/17/2016	1	Group F005598 July, 2016 Premium Life Insurance Account #0001 & 0002	092-0000-453500	\$ 6,235.33
[VENDOR] 9156 : MASS MUTUAL	07/01/2016	116-013811		07/01/2016	1	Mass Mutual Payment 7/1/16	010-0000-210127	\$ 26,445.84
[VENDOR] 12125 : CAIC PRIMARY	06/17/2016	116-013542		06/17/2016	1	CAIC Payment - 6/17/16	010-0000-210129	\$ 1,238.72
[VENDOR] 13454 : LYNCH	07/01/2016	116-013798		07/01/2016	1		010-0000-210110	\$ 425.60
[VENDOR] 13548 : AXA EQUITABLE LIFE INSURANCE COMPANY	07/01/2016	116-013800		06/28/2016	1	AXA Payment 7/1/16	010-0000-210131	\$ 405.00
GRAND TOTAL :								\$ 44,013.42

Village of Orland Park
Open Item Listing

Run Date: 07/01/2016 User: bobrien

Status: POSTED Due Date: 07/01/2016
Bank Account: BMO Harris Bank-Vendor Disbursement
Invoice Type: Payroll - Auto Pay Created By: All

Vendors	Vendor Invoice	Invoice	Purchase Order	Due Date	Line No	Line Item Description	Account Number	Amount
[VENDOR] 3925 : ILLINOIS DEPARTMENT OF REVENUE	07/01/2016	116-013802		07/01/2016	1	State Tax Payment 7/1/16	010-0000-215101	\$ 39,745.05
[VENDOR] 8489 : UNITED STATES TREASURY	07/01/2016	116-013810		07/01/2016	1	Federal Tax Payment 7/1/16	010-0000-215100	\$ 140,070.81
	07/01/2016	116-013810		07/01/2016	2	Federal Tax Payment 7/1/16	010-0000-215102	\$ 103,566.06
	07/01/2016	116-013810		07/01/2016	3	Federal Tax Payment 7/1/16	010-0000-215103	\$ 34,404.28
[VENDOR] 13507 : EXPERT PAY	07/01/2016	116-013799		07/01/2016	1	Support Payment 7/1/16	010-0000-210110	\$ 8,168.04
[VENDOR] 13657 : BMO HARRIS BANK N.A.	07/01/2016	116-013801		07/01/2016	1	Flexible Spending Payment 7/1/16	010-0000-210107	\$ 1,916.42
GRAND TOTAL :								\$ 327,870.66

Village of Orland Park
Open Item Listing

Run Date: 07/01/2016 User: bobrien

Status: POSTED Due Date: 06/30/2016
 Bank Account: BMO Harris Bank-Vendor Disbursement
 Invoice Type: Payroll - Auto Pay Created By: All

Vendors	Vendor Invoice	Invoice	Purchase Order	Due Date	Line No	Line Item Description	Account Number	Amount
[VENDOR] 1398 : ILLINOIS MUNICIPAL RETIREMENT FUND	06/30/2016	116-013861		06/29/2016	1	MONTHLY IMRF PAYMENT	010-0000-130800	\$ 22,808.26
	06/30/2016	116-013861		06/29/2016	1	MONTHLY IMRF PAYMENT	010-0000-210102	\$ 194,197.21
	06/30/2016	116-013861		06/29/2016	1	MONTHLY IMRF PAYMENT	010-0000-210124	\$ 12,344.46
GRAND TOTAL :								\$ 229,349.93

Village of Orland Park Open Item Listing

Run Date: 06/29/2016 User: bobrien

Status: POSTED Due Date: 06/29/2016
Bank Account: BMO Harris Bank-Open Lands
Invoice Type: Open Lands Invoice Created By: All

Vendors	Vendor Invoice	Invoice	Purchase Order	Due Date	Line No	Line Item Description	Account Number	Amount
[VENDOR] 1165 : COM ED	0051636018	116-013120		06/07/2016	1	4/13-5/12/16 - Stellwagen	029-0000-441300	\$ 26.78
	0051636018	116-013121		06/07/2016	1	3/15-4/13/16 - Stellwagen	029-0000-441300	\$ 27.52
[VENDOR] 1601 : NICOR	3709073	116-013094		06/07/2016	1	3/7-4/6/16 - Boley	029-0000-441700	\$ 50.21
	3709073	116-013095		06/07/2016	1	4/6-5/5/16 - Boley	029-0000-441700	\$ 40.51
[VENDOR] 6232 : ILLINOIS CHARITY BUREAU FUND	01048212	116-013687	16-001857	06/27/2016	1	AG990 Illinois Filing Fee	029-0000-432200	\$ 15.00
	01030283	116-013688	16-001858	06/27/2016	1	AG990 Illinois Filing Fee	029-0000-432200	\$ 15.00
[VENDOR] 7874 : AMPEST EXTERMINATING & WILDLIFE CONTROL	T36630	116-013316	16-001626	06/09/2016	1	Rodent control at Boley Farm	029-0000-432910	\$ 150.00
[VENDOR] 13912 : UPLAND DESIGN LTD.	15-490-01	116-013451	16-001581	06/14/2016	1	Final design and engineering of the Orland Park Nature Center project - 2/29-4/30/16	029-0000-470700	\$ 5,400.00
GRAND TOTAL :								\$ 5,725.02

**Village of Orland Park
Open Item Listing**

Run Date: 06/28/2016 User: bobrien

Status: POSTED Due Date: 06/30/2016
Bank Account: BMO Harris Bank-Vendor Disbursement
Invoice Type: All Created By: All

Vendors	Vendor Invoice	Invoice	Purchase Order	Due Date	Line No	Line Item Description	Account Number		Amount
[VENDOR] 8558 : ORLAND PARK BUILDING CORPORATION	07/01/16	116-012158	16-000056	06/30/2016	1	Principal only - quarterly payments for Orland Plaza Acquisition - 3rd qtr	282-0000-480370	\$	255,481.41
	07/01/16	116-012158	16-000056	06/30/2016	2	Interest only - quarterly payments for Orland Plaza Acquisition - 3rd qtr	282-0000-480380	\$	7,741.34
GRAND TOTAL :								\$	263,222.75

REQUEST FOR ACTION REPORT

File Number: **2016-0444**
Orig. Department: **Police Department**
File Name: **Disposal of Certain Seized Vehicles at Public Auction - Ordinance**

BACKGROUND:

The Police Department requests that the Village declare four (4) forfeited vehicles, described herein, as excess property and dispose of at public auction. The vehicles were seized by the department and forfeited to the Village by the Circuit Court of Cook County from drivers who were driving their vehicle while their license was suspended for DUI.

The vehicles are described herein as follows:

2003 Cadillac/Seville	1G6KY54943U279315
2005 Mercury/Montego	1MEFM43155G611942
1995 Buick/Century	1G4AG55M1S6413694
2007 Mitsubishi/Eclipse	4A3AK34T37E019513

On June 20, 2016, this item was reviewed by the Public Safety Committee and referred to the Village Board for approval.

BUDGET IMPACT:

Proceeds from the auction will be deposited into the State Asset Forfeiture fund of the Village of Orland Park Account #027-0000-372450

REQUESTED ACTION:

I move to pass Ordinance Number _____, entitled: ORDINANCE AUTHORIZING DISPOSAL BY PUBLIC AUCTION OF PERSONAL PROPERTY (VEHICLES) OWNED BY THE VILLAGE OF ORLAND PARK, ILLINOIS

VILLAGE OF
Orland Park

DEPARTMENT OF POLICE
INTEROFFICE MEMORANDUM

TO: Chief Timothy McCarthy
FROM: Lieutenant Timothy McCormick #111
DATE: June 9th 2016
RE: Seized and Impounded Vehicles Ready for Auction

Below is a list of four (4) forfeited vehicle's being processed for title in the name of the Village of Orland Park. It will be ready for auction. This auction will be conducted by Clinton Auto Auction in Clinton, Illinois or Tri-State Auto Auction of Chicago, 14001 S. Karlov, Crestwood, Illinois, 60445.

<u>Vehicle Year Make and Model</u>	<u>Vehicle Identification #</u>	<u>Mileage</u>
1) 2003 Cadillac / Seville	1G6KY54943U279315	138286
2) 2005 Mercury / Montego	1MEFM43155G611942	Broken
3) 1995 Buick / Century	1G4AG55M1S6413694	79675
4) 2007 Mitsubishi / Eclipse	4A3AK34T37E019513	135534

..T

ORDINANCE AUTHORIZING DISPOSAL BY PUBLIC AUCTION OF PERSONAL PROPERTY (VEHICLES) OWNED BY THE VILLAGE OF ORLAND PARK, ILLINOIS

..B

WHEREAS, at least a simple majority of the Corporate Authorities of the Village of Orland Park have decided that it is no longer necessary or useful for the Village of Orland Park to retain ownership of the personal property (vehicles) described below; and

WHEREAS, at least a simple majority of the said Corporate Authorities have therefore decided that continued ownership of the vehicles described below is not in the best interests of the Village of Orland Park; and

WHEREAS, the vehicles listed below are either Village-owned police vehicles that have exhausted their usable life or are vehicles that have been seized by the Village Police Department from drivers who were driving their vehicles while their drivers' licenses were suspended for DUI or other violations, causing the vehicles to be seized and forfeited to the Village by order of the Circuit Court of Cook County; and

NOW, THEREFORE, BE IT ORDAINED by the President and Board of Trustees of the Village of Orland Park, Illinois, as follows:

SECTION 1

The above recitals are hereby incorporated into this section as fully as if they were set forth herein in their entirety.

SECTION 2

Pursuant to Section 11-76-4 of the Illinois Municipal Code, Illinois Compiled Statutes, 65 ILCS 5/11-76-4, the President and the Board of Trustees of the Village of Orland Park find that the items of personal property listed on EXHIBIT A (vehicles) now owned by the Village of Orland Park, Illinois, are no longer necessary or useful to the said Village and its best interests will be served by the sale at public auction of such vehicles.

SECTION 3

Pursuant to the said Section 11-76-4, the Village Manager is hereby authorized to and may direct the sale of the personal property to which Section 2 of this Ordinance refers as, "AS IS" and without warranties at public auction. The said public auction shall to be conducted by the auction house named on EXHIBIT A ("the "Auction House").

SECTION 4

The Auction House named on EXHIBIT A is hereby authorized and directed to advertise the sale of the vehicles listed on EXHIBIT A before the date of said public auction.

SECTION 5

No bid which is less than the minimum value as provided by the Village Manager to the Auction House shall be accepted by the Auction House as the sales price of property listed on EXHIBIT A of this Ordinance unless a lower amount is authorized by the Village Manager or his representative.

SECTION 6

Upon payment of the full sales price of a vehicle to the Village of Orland Park, the Village Manager and/or Village President is hereby authorized and directed to convey and transfer title to each purchased vehicle from the Village to the successful bidder/buyer and to execute all documents necessary to effectuate the sale.

SECTION 7

This Ordinance shall be in full force and effect from and after its passage, by a vote of at least a simple majority of the Corporate Authorities, and approval in the manner provided by law.

DATE: July 5, 2016

REQUEST FOR ACTION REPORT

File Number: **2016-0304**
Orig. Department: **Development Services Department**
File Name: **Southside Chicago Hitmen**

BACKGROUND:

PROJECT: Southside Chicago Hitmen

PETITIONER: Robert Ortiz, President

PURPOSE: The petitioner requests special use permit approval to operate a club in the BIZ zoning district.

LOCATION: 7040 157th Street

PIN NUMBER: 28-18-309-009

ATTACHMENTS

Plat of Survey
Floor Plan
Response to Special Use Standards

SIZE: 1,300 SF

EXISTING ZONING AND LAND USE:
BIZ General Business District - Vacant

SURROUNDING ZONING AND LAND USE:
North: MFG - Manufacturing District / Multi-Tenant Light Industrial
South: BIZ - General Business District / Grocery Store
East: BIZ - MFG - Manufacturing District/ Multi-Tenant Light Industrial
West: BIZ - General Business District / Commercial

COMPREHENSIVE PLAN DESIGNATION:
Manufacturing Employment Emphasis

TRANSPORTATION:

There are currently eight driveways on the south and east sides of the site that open onto 157th Street and 70th Court. Per the conditions of appearance review 2015-0485 six of the existing driveways will be closed. The main access points to the site after the improvements will be a full access curb cut at the southwest corner of the site one at the northwest corner of the site that open onto 157th Street, an Orland Park local street, and 70th Court, an Orland Park local street, respectively.

PLANNING OVERVIEW and DISCUSSION:

The Southside Chicago Hitmen a Chapter of the IRPMC is a not for profit charitable organization. The members are local police officers and firefighters. The Orland Park location is comprised of police officers from departments throughout Cook County and a firefighter from the City of Chicago. Their primary function is organizing benefits and fundraisers for injured and fallen police officers and firefighters.

The Orland Park location currently has 15 members. There are 46 existing Chapters of IRPMC throughout the United States. This includes 3 existing locations in Illinois (Calumet City, Joliet, Quad Cities). The Orland Park location will be used primarily for membership meetings and storage. The chapter meets approximately twice a month. Typically, they will only meet once a month to discuss general chapter business and upcoming events. They also will meet as needed if an emergency situation occurs. All meetings begin at 7:30pm. The other tenants in the building operate at normal business hours. This combined with the relatively low membership at this location will help avoid any potential traffic or parking conflicts with the adjacent uses.

Land Use/Compatibility:

Clubs and lodges are conditionally appropriate in the BIZ zoning district. Clubs in this district must obtain special use permit approval.

Landscaping:

There are no proposed changes to the existing site plan or landscaping.

Parking/Loading:

The Land Development Code does not define the required amount of parking spaces for a club or lodge. In this instance the code stipulates that the Development Services Department shall determine the number of off-street parking spaces that shall be required.

In the BIZ zoning district the most common uses are either commercial retail or office. Below shows the amount of parking required for this location if it were all retail or all office.

All Retail - (1 per 250 SF) 5 parking spaces

All Office - (1 per 300 SF) 4 parking spaces

Deferring to the most stringent regulation this use is required to provide 5 parking spaces. Per Appearance Review 2015-0485, the entire building would need 122 spaces to be code compliant. The improvements outlined in the appearance review will add parking. Leaving the site with a total of 106 spaces. This brings the site closer to code compliance. Since parking supporting the club will only be utilized once or twice a month at night there is sufficient parking to support this use.

Garbage Enclosure:

Garbage enclosures have been added to the rear of the property as required by appearance review 2015-0485.

Building Elevations:

There are no changes to the exterior of the building or site. Signage will be permitted and approved via a separate sign permit review, which is not a part of this approval.

This is now before Plan Commission for consideration.

PLAN COMMISSION MOTION

On May 24, 2016, the Plan Commission, by a vote of 5-0 moved to recommend to the Village Board of Trustees approval of a Special Use Permit for a club for the Southside Chicago Hitmen a Chapter of IRPMC as fully referenced below.

The motion includes the following conditions:

1. That the Petitioner comply with all Building and Health Code requirements; and
2. That all new signage is approved through a separate permitting process.
3. Meet conditions of Appearance Review 2015-0485.

PLAN COMMISSION DISCUSSION

The Plan Commission viewed the proposed Special Use Permit very favorably and thus recommended no modifications to the petition as proposed. In addition, there was no one in the audience regarding this project.

DEVELOPMENT SERVICES PLANNING AND ENGINEERING COMMITTEE

On June 20, 2016, this item was reviewed by the Development Services Planning and Engineering Committee, recommended 3-0 for approval and referred to the Village Board of Trustees for consideration.

DEVELOPMENT SERVICES PLANNING AND ENGINEERING COMMITTEE DISCUSSION

The Development Services Planning and Engineering Committee viewed the proposed Special Use Permit favorably and thus recommended no modifications to the petition as proposed. In

addition, there was no one in the audience regarding this project.

BUDGET IMPACT:

REQUESTED ACTION:

I move approve a special use permit for a club for the Southside Chicago Hitmen a Chapter of IRPMC at 7040 157th Street, Orland Park, IL subject to the following conditions:

1. That the petitioner comply with all Building and Health Code Requirements.
2. That all new signage is approved through a separate permitting process.
3. Meet conditions of Appearance Review 2015-0485.

SOUTH SIDE CHICAGO HITMEN OF IRPMC, NFP
7040 W. 157th ST.
ORLAND PARK, IL. 60462

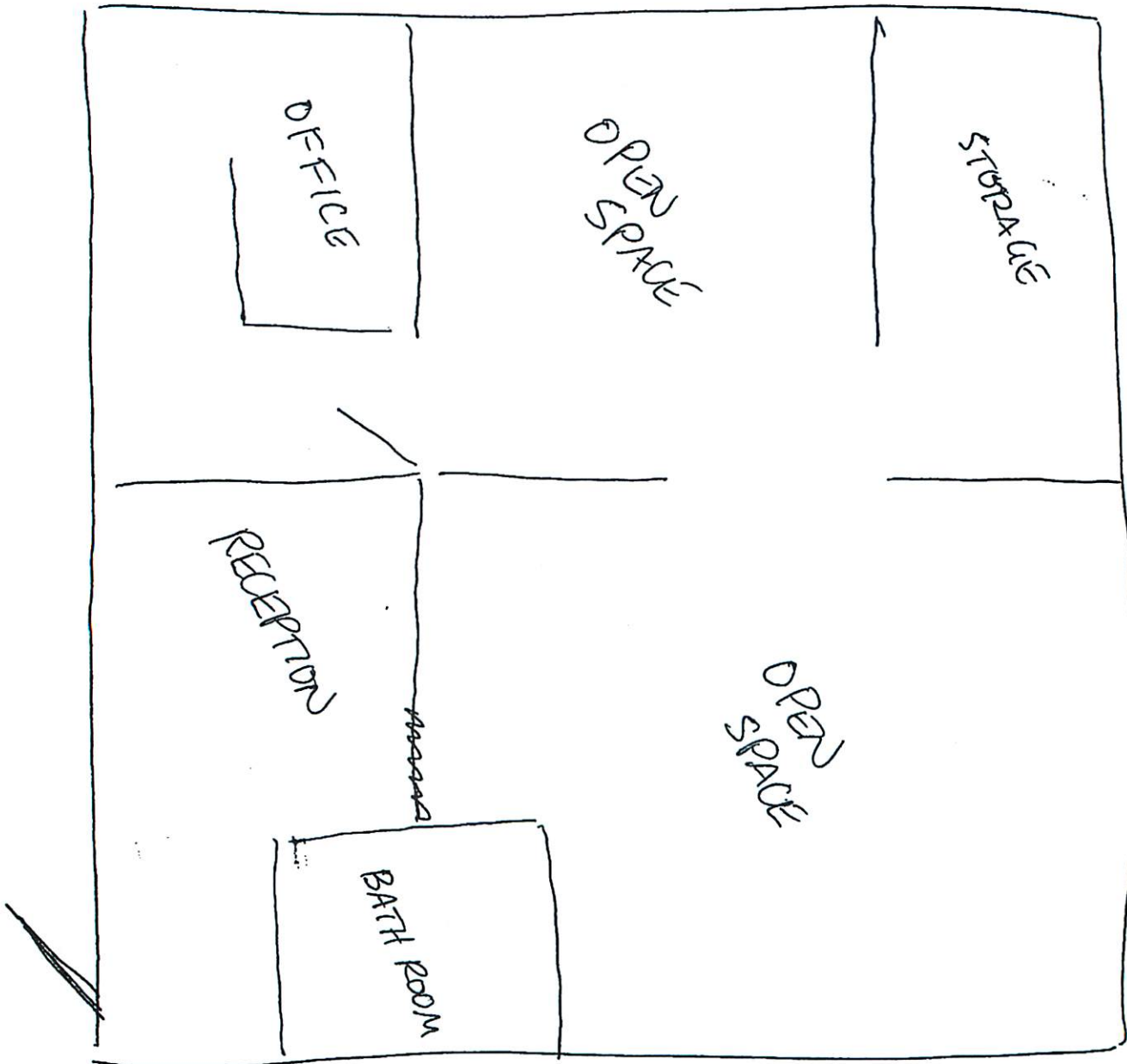

Special Use Standards Answers

1. The special use will be consistent with the purpose, goals and objectives and standards of the Comprehensive Plan, any adopted overlay plan and these regulations; our organization is a not for profit Police and Fire membership which organizes benefits and fundraisers for injured or fallen Police Officer and Fire Fighters. Our members include police officers from departments throughout Cook County and a Fire Fighter from the City of Chicago.
2. The special use will be consistent with the community character of the immediate vicinity of the parcel for development; the surrounding businesses are used to sell a product or service our organization is not a business and we do not offer a service. We are a not for profit organization that organizes benefits and fundraisers for injured or fallen officers and firefighter. This location will be used to conduct our monthly meetings (approximately twice per month) and store supplies.
3. The design of the proposed use will minimize adverse effect, including visual impacts on adjacent properties; there will be no design change to the existing unit and no signage will be posted outside the unit.
4. The proposed use will not have an adverse effect on the value of the adjacent property; Due to the fact that our membership is small and our meetings occur after normal business hours there would be no adverse effect on the value of the adjacent property.
5. The applicant has demonstrated that public facilities and services, including but not limited to roadways, park facilities, police and fire protection, hospital and medical services, drainage systems, refuse disposal, water and sewers, and schools will be capable of serving the special use at an adequate level of service; our organization will not need the services of park facilities, or schools and due to the fact that we will be at the property on an average of twice a month after normal business hours we will not affect the normal roadway conditions.
6. The applicant has made adequate legal provision to guarantee the provision and development of any open space and other improvements associated with the proposed development; there will be no change to any of the property.
7. The development will not adversely affect a known archeological, historical or cultural source; there will be no change to any of the property.
8. The proposed use will comply with all additional standards imposed on it by the particular provision of these regulations authorizing such use and by all other requirements of the ordinances of the Village.

REQUEST FOR ACTION REPORT

File Number: **2016-0313**
Orig. Department: **Development Services Department**
File Name: **Team Rockhouse - Motor Vehicle Services**

BACKGROUND:

QUICKFACTS

Project

Team Rockhouse - Motor Vehicle Services - 2016-0313

Petitioner

David Sosin
Sosin, Arnold and Schoenbeck, Ltd.

Purpose

The purpose of this petition is to establish a motor vehicle service facility in the BIZ General Business District.

Requested Actions: Special Use Permit

Project Attributes

Address: 7060 W. 157th Street

P.I.N.(s): 28-18-309-013-0000

Parcel Size: 0.40 acres (17,000 s.f.)

Building Size: 0.10 acres (4,400 s.f.)

Comprehensive Plan Planning District: 159th and Harlem Planning District

Comprehensive Land Designation: Manufacturing Employment Emphasis

Existing Zoning: BIZ General Business District

Existing Land Use: Vacant (formerly Taylor Rental Center)

Proposed Land Use: Motor Vehicle Service facility (Auto Repair and Maintenance)

Surrounding Land Use:

North: BIZ General Business District - Multi-tenant Building (71st Court Plaza)

South: BIZ General Business District - (across 157th St) Commercial / Retail (Meijer's)

East: BIZ General Business District - Multi-tenant (South Pointe Industrial Building)

West: BIZ General Business District - Commercial / Retail (Sherlock's Carpet)

Preliminary Engineering: Preliminary engineering is not required for this project.

PROJECT DESCRIPTION & CONTEXT

The petitioner proposes to operate and maintain a motor vehicle service facility at 7060 W. 157th

Street. The business, named Team Rockhouse, will focus primarily on the repair and maintenance of vehicles (a full scope of work is provided below). As the building is comprised of a 1,800 SF retail area and a 2,600 SF garage/warehouse space, the petitioner also has future plans for auto-parts retail sales; however, no new or used automobile sales of any kind are allowed on premises. A special use is not required for auto-parts retail sales in the BIZ General Business District.

Because the petitioner is occupying an existing building, many of the issues that come with new development, including lot coverage, setbacks and height, do not apply in this case. The primary purpose of this petition is to consider the allowance of the Special Use Permit for a motor vehicle service use. Section 6-207.C.11 of the Land Development Code requires a special use permit for motor vehicle services in a BIZ Business District. Potential issues include adjacency to residential (Ordinance 4574), compatibility with surrounding uses, and the noise/fumes that the use might create.

The petitioner would be moving into a space previously used for the rental of tools and machinery. The petitioner is not proposing any changes to the exterior building or property, and no vehicles will be stored on site for more than 5 days at a time, which would require outdoor storage screening. Because the proposed use will not have any negative impact on surroundings land uses, no incremental improvements are requested.

There are no modifications or variances proposed for this project.

The recommendation motion includes the following conditions:

- 1) That no new or used automobile sales of any kind are allowed on premises;
- 2) That all work is conducted indoors;
- 3) That garage doors facing residential areas remain closed at all times except for the exchange of vehicles;
- 4) That vehicles parked outside for more than five (5) business days are considered outdoor storage and will require additional screening per Village requirements;
- 5) That a triple basin is installed and inspected by Village Building Division;
- 6) That an MWRD permit is obtained if determined necessary by the Village.

Overall, the project conforms to the Village's Comprehensive Plan, Land Development Codes and policies for this area.

Plan Commission Motion

On June 14, 2016, the Plan Commission, by a vote of 5-0, moved to recommend to the Village to approve the special use permit for a motor vehicle service for Team Rockhouse, as fully referenced below.

Plan Commission Discussion

On June 14, 2016, a public hearing was held before the Plan Commission. No members of the public spoke. Team Rockhouse representatives were in the audience and available for questions. Mr. Brian Nussbaum, the attorney representing the petitioner, requested a modification to the wording of one of the conditions of the motion to allow for a "relief" of three (3) months to install a triple basin (a triple basin is required by the Building Division of all motor vehicle service uses). Mr. Nussbaum said the petitioner needed the three (3) months to obtain estimates, to decide whether to install the basin inside or outside of the building, and to save up enough money to afford the installation of the triple basin. Commissioner Jacobs asked if the

building owner would help with the cost of the triple basin. Mr. Nussbaum responded that the building owner had not yet considered that idea. Commissioners Parisi and Stephens both suggested operating a motor vehicle service business for three (3) months without the proper safety requirements installed would not be a good idea due to safety concerns. Staff responded that the condition of the motion should not be modified, and that the Building Division would ultimately decide if such an extension of time could be granted.

Ultimately, Mr. Nussbaum's request to change the motion text to reflect the petitioner's request for an extension of time to install the triple basin was denied. In the end, all five (5) Commissioners in attendance had a generally positive response to and spoke in support of the project. The motion passed unanimously 5 - 0.

Post-Plan Commission Discussion

On June 15, 2016, details of the Plan Commission were reported to the Building Division Manager, Mike Coleman. Mr. Coleman decided that the petitioner has two (2) options; 1) that the petitioner shall submit a building permit and install the triple basin and any other Building Code related items immediately, thus allowing the petitioner to engage in the proposed full scope of work; or 2) that the petitioner would be allowed three (3) months to install a triple basin and any other Building Code related items, but the scope of work allowed during those three (3) months would be limited to only those activities not related to the handling of hazardous or objectionable materials. If Option 2 was selected by the petitioner, a notarized letter agreeing to this revised scope of work pending the installation of a triple basin would need to be submitted to the Village. A decision on this matter will be reflected in this project's Board report, which is set for July 5, 2016.

Development Services And Planning Committee Motion

On June 20, 2016, this item was reviewed by the Development Services Planning and Engineering Committee, recommended for approval by a vote of 3 - 0 and referred to the Village Board of Trustees for consideration.

Post-Plan Commission Discussion

On June 27, 2016 the petitioner submitted a letter to the Village stating that a triple basin would be installed immediately. The basin would be installed inside the building, thus not requiring a separate MWRD permit. A Building permit and associated inspections will be required for the triple basin's installation.

This case is now before the Village Board of Trustees for consideration.

BUDGET IMPACT:

REQUESTED ACTION:

I move to approve a Special Use Permit for Team Rockhouse to locate a motor vehicle service facility at 7060 157th Street as recommended at the June 14, 2016 Plan Commission meeting and as fully referenced below.

(THIS SECTION FOR REFERENCE ONLY (NOT NECESSARY TO BE READ))

I move to approve a Special Use Permit for Team Rockhouse to locate a motor vehicle service

facility at 7060 157th Street, subject to the following conditions:

- 1) That no new or used automobile sales of any kind are allowed on premises;
- 2) That all work is conducted indoors;
- 3) That garage doors facing residential areas remain closed at all times except for the exchange of vehicles;
- 4) That vehicles parked outside for more than five (5) business days are considered outdoor storage and will require additional screening per Village requirements;
- 5) That a triple basin is installed and inspected by Village Building Division;
- 6) That an MWRD permit is obtained if determined necessary by the Village.

RETAIL / GARAGE / WAREHOUSE AVAILABLE



7060 W 157th St. | Orland Park, IL 60462

NRT



PROPERTY OVERVIEW

Former party rental store with 1,800 SF of showroom and 2,600 SF of garage/warehouse space with two overhead drive-in doors. Good parking on all sides of building. Site is fenced and paved. New roof in Fall 2014.

Located on busy 157th Street, the feeder street to the newer Meijer Store, one block east of and visible from Harlem Avenue. Neighborhood retailers include Home Depot, Menards, Bakers Square, Famous Dave's, Panera Bread and Cooper's Hawk.

Traffic Counts include 39,300 vehicles per day along W 159th Street and 40,500 cars per day along Harlem Avenue.

DETAILS

SIZE: 4,400 SF

LOT SIZE: 17,000 SF

ZONING: BIZ

FEATURES: - Two (10' x 12') drive-in doors
- 12' ceiling height

DEMOGRAPHICS:

	1-mile	3-mile	5-mile
Population	11,634	92,672	202,886
Households	4,986	35,519	76,641
Avg HH Income	\$82,506	\$69,782	\$68,764

2014/2015 Demographics provided by Experian through Alteryx

FOR MORE DETAILS CONTACT:

Phil Wegele | pwegele@pw2co.com

Direct: 847-226-4940

14470 S. LaGrange, Suite 104
Orland Park, IL 60462

CBCWorldwide.com

The broker has NOT undertaken an independent investigation to verify the accuracy or completeness of the information herein, except as required by law or regulation. The information contained herein has been provided to the Broker by the Owner or has been obtained from other third party sources deemed to be reliable. Prior to entering into a contract, Purchaser is strongly encouraged to verify the accuracy of all information contained herein, including all information concerning Purchaser's intended use of the property. Operated by NRT LLC.

The broker has NOT undertaken an independent investigation to verify the accuracy or completeness of the information herein, except as required by law or regulation. The information contained herein has been provided to the Broker by the Owner or has been obtained from other third party sources deemed to be reliable. Prior to entering into a contract, Purchaser is strongly encouraged to verify the accuracy of all information contained herein, including all information concerning Purchaser's intended use of the property. Operated by NRT LLC.

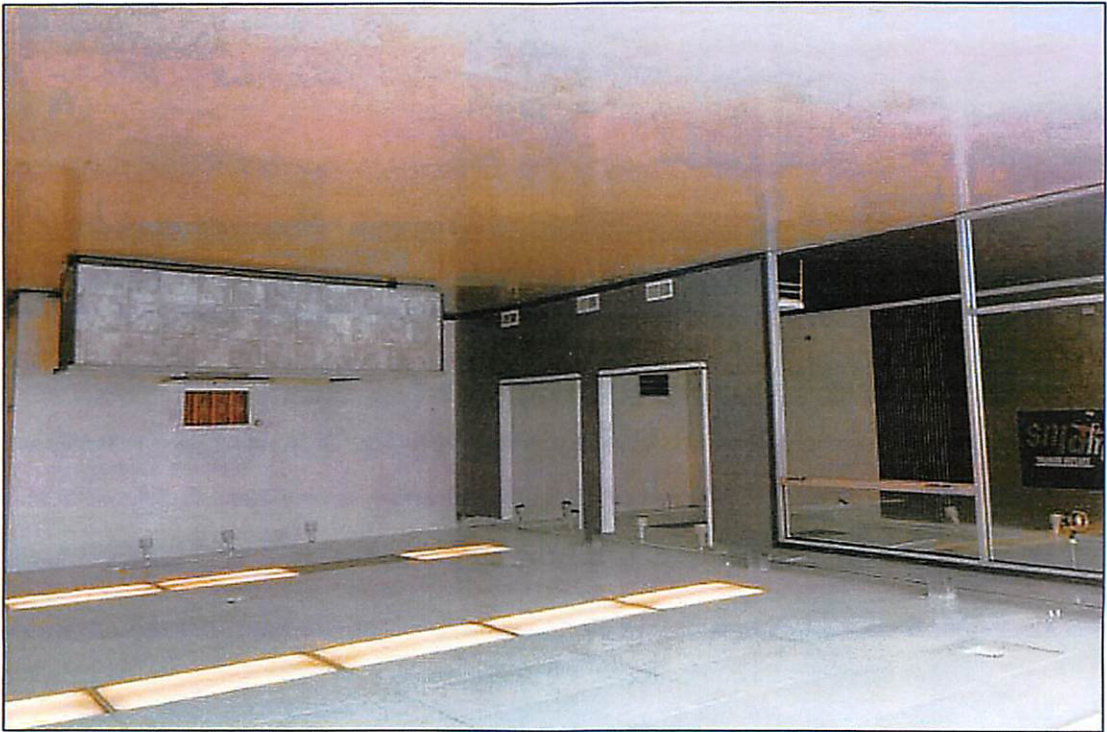
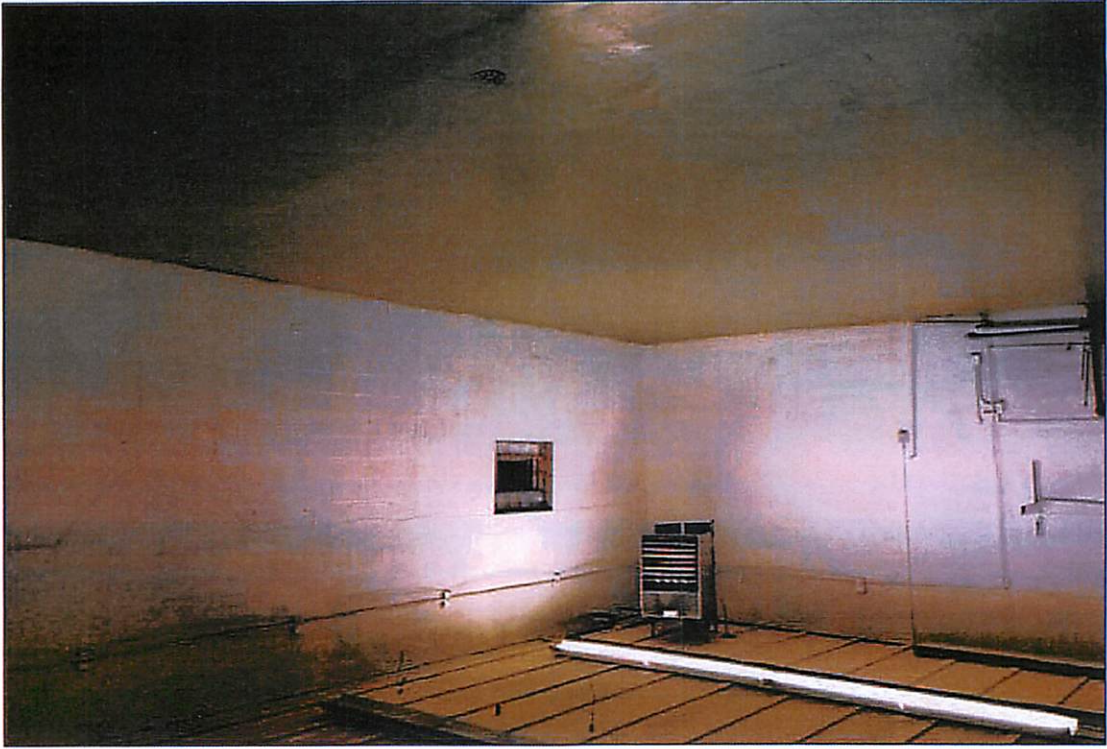

NRT

7060 W 157th St. | Orland Park, IL 60462

COLDWELL
BANKER
COMMERCIAL



AVAILABLE

RETAIL/GARAGE/WAREHOUSE





SOSIN,
ARNOLD &
SCHOENBECK LTD.
ATTORNEYS AT LAW

9501 West 144th Place, Suite 205
Orland Park, Illinois 60462-2563
Telephone: (708) 448-8141
Facsimile: (708) 448-8140

DAVID B. SOSIN*
GEORGE J. ARNOLD†
GEORGE L. SCHOENBECK
STEVEN D. MROCZKOWSKI†
CHRISTINE A. WALCZAK
JWAN L. ARNOLD
BRIAN D. NUSSBAUM

Of Counsel:
TIMOTHY G. LAWLER

*Also admitted in Indiana
†Also admitted in Wisconsin

BRIAN D. NUSSBAUM
bnussbaum@sosinarnold.com

June 3, 2016

Mr. Michael Mazza
Development Services Department
14700 Ravinia Avenue
Orland Park, IL 60462

Re: 7060 W. 157th Street, Orland Park, IL,

Dear Mr. Mazza,

This letter is intended to respond to questions you recently posed relating to our client's request for Special Use at the above-captioned property. You inquired about the scope of the work and how objectionable waste will be handled at the site. The proposed scope of work is as follows:

1. Repair, Replace or Install engines, transmissions, brakes, alarms, remote starts, tires/rims;
2. Restoration, Fender or Body Work;
3. Custom aesthetic requests from clients;
4. Paint jobs in an EPA approved portable spray booth; and
5. Tune ups.

In regards to the objectionable waste, the client uses special containers to catch any objectionable waste while working on the vehicles. These containers are used to ensure the waste does not get into the sewer system. Once the waste is captured in the container, a third party vendor is called to remove the objectionable waste from the site. The third party vendor used for removal is Future Environmental, Inc. Their IEPA Special Waste Hauling Permit number is 3922. I have enclosed Future Environmental, Inc.'s Permit Book with this letter. Additionally, we have consulted with an environmental engineer at the Metropolitan Water Reclamation District who has advised us no permit is necessary for our client.

Should you have any further questions please do not hesitate to ask.

Very truly yours,

SOSIN, ARNOLD & SCHOENBECK, LTD.

A handwritten signature in blue ink, appearing to read "B. Nussbaum", with a long horizontal flourish extending to the right.

Brian D. Nussbaum

BDN
Enclosure

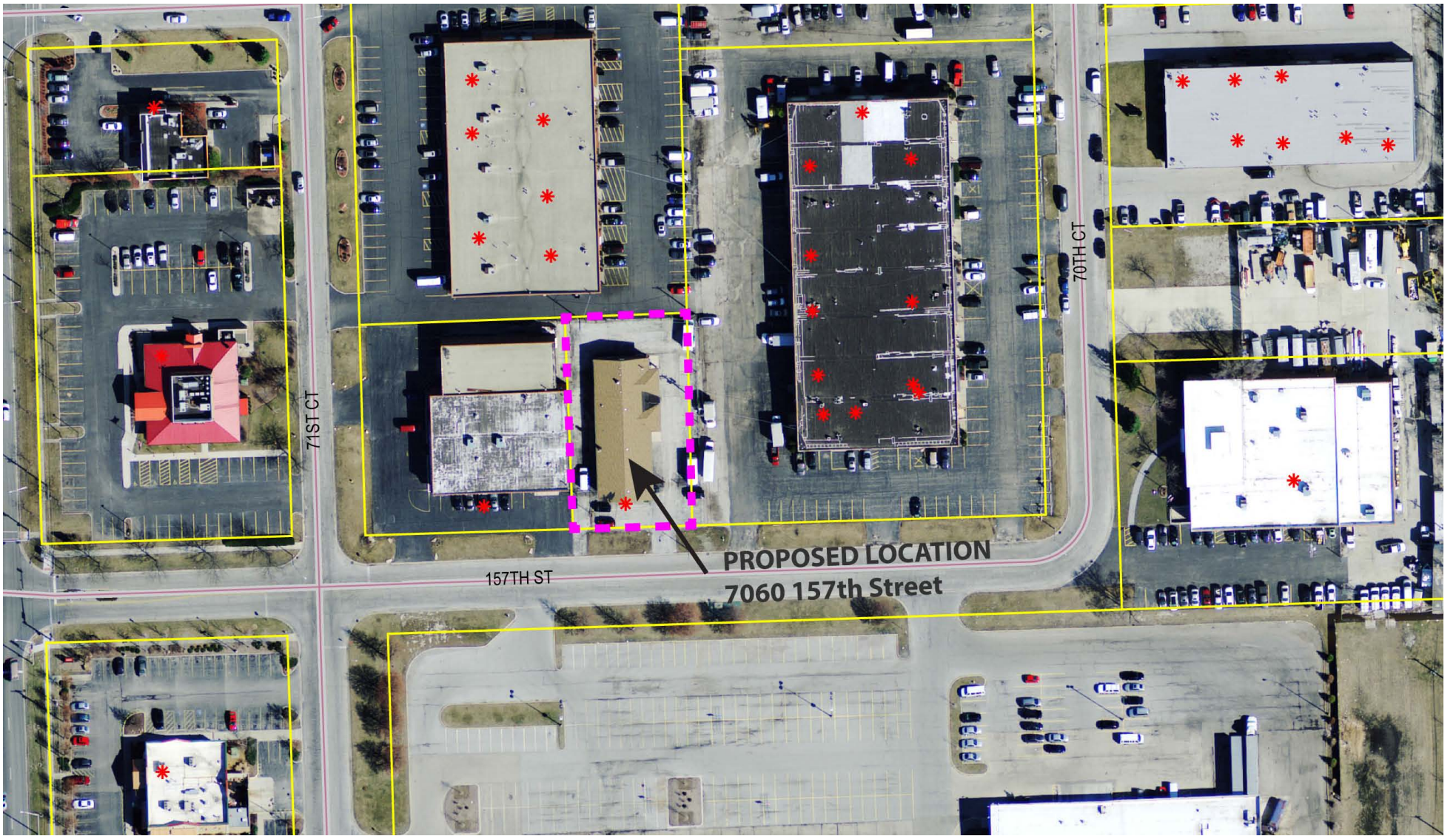

PROPOSED LOCATION
7060 157th Street

71ST CT

70TH CT

157TH ST

PETITION FOR SPECIAL USE PERMIT – 7060 W. 157th STREET

STANDARDS APPLICABLE TO SPECIAL USES

The Petitioner is requesting a Special Use permit for the use of the site as an auto services facility.

1. The former use of the site as an auto rental facility is similar to the proposed use of the site as an auto services facility. The use of the site as an auto services facility is similar in nature to the surrounding properties' uses as car washes, car detailing services, auto parts stores, and other auto services. Further, the Village of Orland Park has previously granted a special use permit for the operation of a rental facility with motor vehicles such as tractors and trailers at the site. Thus, the use of the site as an auto services facility is consistent with the goals, policies and standards of Orland Park's BIZ district development.

2. The use of the site as an auto services facility is consistent with the community character of the immediate vicinity of the parcel for development. The Petitioner will use the 1,800 square foot showroom and 2,600 square foot garage/warehouse space (with two overhead drive-in doors) at the site as an auto services facility.

3. The use of the site as an auto services facility will not have an adverse visual impact on adjacent properties and will not alter the character of the area or adversely have an impact upon the health, safety and general welfare of the area. The side area is fenced for overnight parking.

4. The use of the site as an auto services facility will not have an adverse effect on the value of adjacent property. The area is zoned for the proposed use and similar uses. Such uses have not impeded the continued retail development to the South.

5. Public facilities and services will be capable of serving the use of the site as an auto services facility at an adequate level of service. Also, the use of the site as an auto services facility will not create any burden to schools and hospital and medical facilities.

6. The request for a special use does not contain any request to revise the current provisions for open space and improvements.

7. There are no known archaeological, historical or cultural resources which will be adversely affected by the use of the site as an auto services facility. The use of the site as an auto services facility will not result in the destruction, loss or damage of natural, scenic or historic features of significant importance.

8. The use of the site as an auto services facility will comply with additional standards imposed on it by the particular provision of these regulations authorizing such use and by all other requirements of the ordinances of the Village of Orland Park.

REQUEST FOR ACTION REPORT

File Number: **2016-0344**
Orig. Department: **Development Services Department**
File Name: **Cosmetic Enhancement Clinic and Academy**

BACKGROUND:

QUICKFACTS

Project

Cosmetic Enhancement Clinic and Academy - 2016-0344

Petitioner

Christina Wakulich

Purpose

The purpose of this petition is to establish a permanent makeup clinic and academy in a multi-tenant office building located in the COR Mixed Use District.

Requested Actions: Special Use Permit

Project Attributes

Address: 64 Orland Square Drive, Suite 116

P.I.N.(s): 27-10-301-013-0000

Building Size: 13,000 s.f.

Tenant Size: 1,330 s.f.

Comprehensive Plan Planning District: Regional Core Planning District

Comprehensive Land Designation: Regional Mixed Use

Existing Zoning: BIZ General Business District

Existing Land Use: Vacant Office Unit

Proposed Land Use: Tattoo / Body Piercing Shop

Surrounding Land Use:

North: COR Mixed Use District - Orland Square Mall

South: BIZ General Business District - (across 151st St) Vacant

East: COR Mixed Use District - Multi-tenant Office Building

West: COR Mixed Use District - Detention Pond

Preliminary Engineering: Preliminary engineering is not required for this project.

OVERVIEW AND BACKGROUND

The petitioner currently operates "Xtina's Lash Extension", a business which occupies an office space at 62 Orland Square Drive, which offers lash extensions, waxing, massage and spray tan

services. The proposed “Cosmetic Enhancement Clinic and Academy” would occupy an office space at 64 Orland Square Drive, which is located directly south of 62 Orland Square Drive office building. The newly proposed business would offer permanent makeup and cosmetic enhancement services, along with the possibility of providing technical training to other interested in learning about these services.

Permanent makeup / cosmetic enhancement can be performed by using two (2) different methods: 1) manual application or 2) application with the aid of a small hand held machine, which is similar to a tattoo pen but specifically design for cosmetics. The petitioner would utilize a combination of both methods, depending on the specific application.

Cosmetic enhancements primarily include work done to eyebrow, eyeliner, lips, but may also include:

- 1) Micro pigmentation of the scalp for people with thinning hair or alopecia;
- 2) Para-medical procedures;
- 3) Tinting the skin to match natural skin color do to Vitiligo;
- 4) Disguising stretch mark/scars to match natural skin tone.

Conventional tattooing is not a part of the proposed business’ scope of work and has not been considered as a part of this special use permit.

PROJECT DESCRIPTION & CONTEXT

The petitioner is requesting permission to establish a permanent makeup clinic and academy at 64 Orland Square Drive, Unit 116, which is a multi-tenant office building located in the COR Mixed Use District. The primary use of the business will be as a permanent makeup clinic. This use is considered a Tattoo / Body Piercing establishment per Village Code, which requires a special use permit in the COR Mixed Use District. Ancillary to this primary use is an “academy”, in which 1-2 students would spend a week on site and receive training as permanent makeup technicians. No special permitting is required for the training aspect of the business’ scope of work.

Approval for conventional tattooing (i.e. body art) is not a part of this special use permit and the petitioner has confirmed that such tattooing will not take place on premises.

There are no modifications or variances proposed for this project.

The recommendation motion includes the following conditions:

1. That the Petitioner comply with all Building and Health Code requirements;
2. That conventional tattooing (i.e. body art) shall not take place on premises without a separate Village approval; and
3. That all new signage is approved through a separate permitting process.

Overall, the project conforms to the Village’s Comprehensive Plan, Land Development Codes and policies for this area.

Plan Commission Motion

On June 14, 2016, the Plan Commission, by a vote of 5-0, moved to recommend to the Village to approve the special use permit for the Cosmetic Enhancement Clinic and Academy, as fully referenced below.

Plan Commission Discussion

On June 14, 2016, a public hearing was held before the Plan Commission. No members of the public spoke. All five (5) Commissioners in attendance had a positive response to and spoke in support of the project. Cosmetic Enhancement Clinic and Academy representatives were in the audience and available for questions. The motion passed unanimously 5 - 0.

Development Services And Planning Committee Motion

On June 20, 2016, this item was reviewed by the Development Services Planning and Engineering Committee, recommended for approval by a vote of 3 - 0 and referred to the Village Board of Trustees for consideration.

This case is now before the Village Board of Trustees for consideration.

BUDGET IMPACT:**REQUESTED ACTION:**

I move to approve the special use permit for the Cosmetic Enhancement Clinic and Academy as recommended at the June 14, 2016 Plan Commission meeting and as fully referenced below.

(THIS SECTION FOR REFERENCE ONLY (NOT NECESSARY TO BE READ))

I move to approve a Special Use Permit for the Cosmetic Enhancement Clinic and Academy to locate at 64 Orland Square Drive, subject to the following conditions:

1. That the Petitioner comply with all Building and Health Code requirements;
 2. That conventional tattooing (i.e. body art) shall not take place on premises without a separate Village approval; and
 3. That all new signage is approved through a separate permitting process.
-

PROPOSED LOCATION
64 Orland Square Drive
Unit 116

ORLAND SQUARE DR

151ST ST

REGENT DR

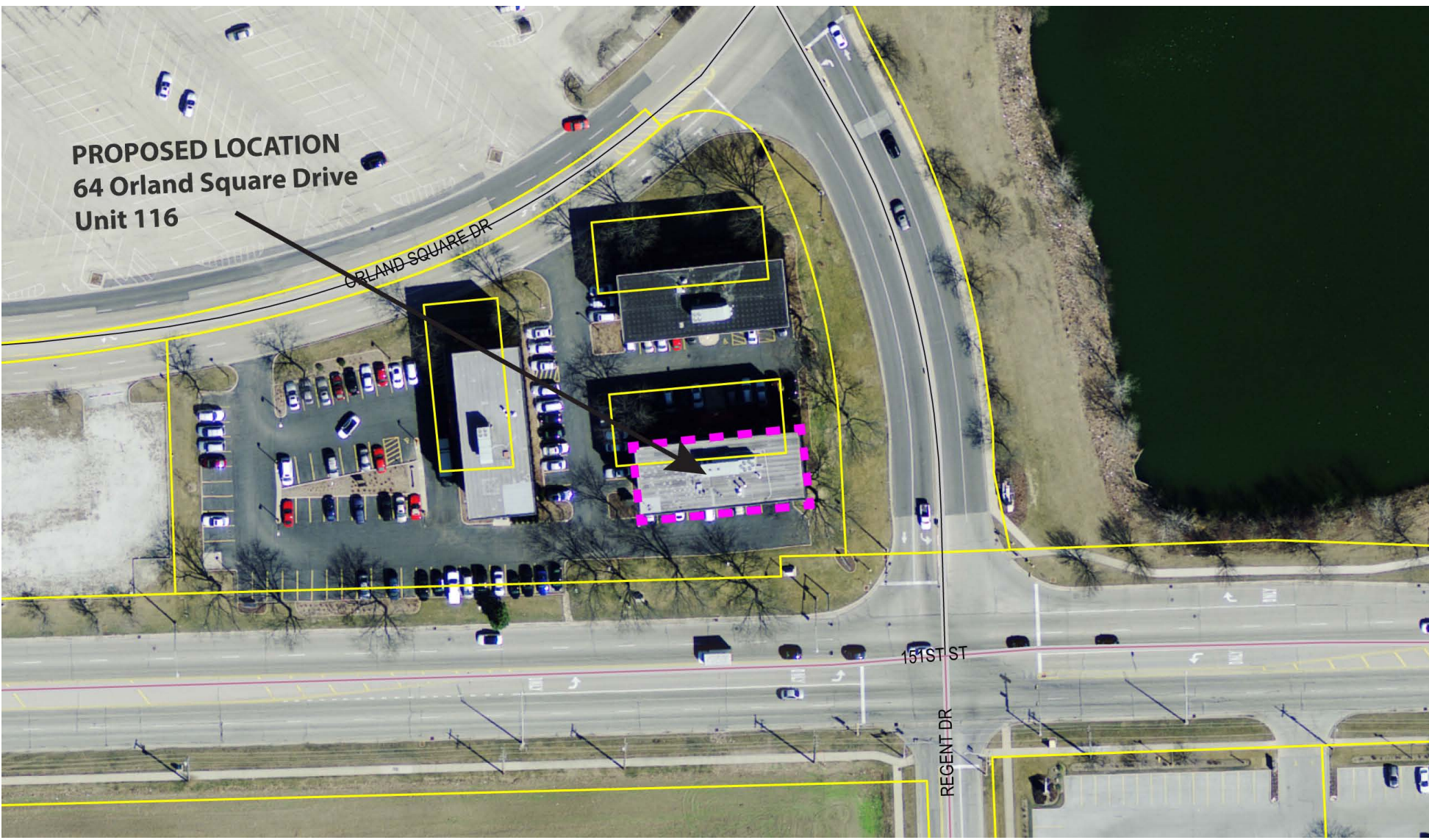

Special Use Standards

1. The special use will be consistent with the purposes, goals and objectives and standards of the *Comprehensive Plan*. The special use being the use of permanent makeup for cosmetic and emotional improvements. To improve the lives of persons affected needing help with appearance due to hardships and skin imperfections.
2. The special use will be consistent with the community character of the immediate vicinity. The business will reside within an already established office suite, with no additional signage outside of the suite.
3. The design of the proposed use will minimize adverse effects, because there will be no changes visually, or to any of the structural supports of the surrounding and adjacent properties. There will be only cosmetic changes made inside the office suite we are leasing, including a sign for the business in the hallway to let our customers identify our business location.
4. The proposed use will not have an adverse effect on the value of the adjacent property, as all the surrounding properties will remain unaffected by a new business simply leasing an office suite within the established building. The commercial suites are filled with many different types of businesses, and filling an empty first floor suite will add to the value of the property.
5. The special use in this case, is just a classification of the business, and will not have any effect on public facilities or services, including roadways, park facilities, police and fire protection, hospital and medical services, drainage systems, refuse disposal, water and sewers, and schools.
6. There will not be any development of open space or other improvements associated with the proposed development, the only changes will be on the inside of the office suite we are leasing and that will be cosmetic changes only (painting, decor, etc.)
7. The development will not adversely affect a known archaeological, historical or cultural resource.
8. The proposed use will comply with all additional standards imposed on it by the particular provision of these regulations authorizing such use and by all other requirements of the ordinances of the Village.

REQUEST FOR ACTION REPORT

File Number: **2016-0456**
Orig. Department: **Development Services Department**
File Name: **2016 Village Code Amendments - Amusement Device Licenses -Title 7-6-2 - Ordinance**

BACKGROUND:

QUICKFACTS

Project

Amusement Device Licenses -Title 7-6-2

Petitioner

Development Services Department

Purpose

The purpose of these amendments is to increase the number of Amusement Device Licenses

Requested Actions: Village Code Amendments

Topics:

Amusement Device Licenses

OVERVIEW AND BACKGROUND

Currently the Village allows twenty (20) amusement device licenses under present code language. With the increase in business within the Village, the Village would like to increase the number of amusement device licenses to twenty five (25). Language with a strike-out (~~strike-out~~) indicates elimination from the Code. Language highlighted indicates the revision to the code. In all cases, language that is bolded and in red (**red**) indicates proposed addition to the Code.

On June 20, 2016, this item was reviewed by the Development Services Planning and Engineering Committee, recommended for approval and referred to the Village Board for consideration.

BUDGET IMPACT:

REQUESTED ACTION:

I move pass Ordinance Number _____, entitled: AN ORDINANCE AMENDING TITLE 7, CHAPTER 6, SECTION 2 OF THE ORLAND PARK VILLAGE CODE INCREASING THE NUMBER OF AUTOMATIC AMUSEMENT DEVICE OPERATORS LICENSES.

..T

AN ORDINANCE AMENDING TITLE 7, CHAPTER 6, SECTION 2 OF THE ORLAND PARK VILLAGE CODE INCREASING THE NUMBER OF AUTOMATIC AMUSEMENT DEVICE OPERATORS LICENSES

..B

WHEREAS, the Village President and Board of Trustees of the Village of Orland Park (the “Village”) have the authority to adopt ordinances and to promulgate rules and regulations that pertain to its government and affairs and to protect the public health, safety and welfare of its citizens; and

WHEREAS, it has been determined that it is in the best interests of the health, safety and welfare of the citizens and residents of the Village to control the number of automatic amusement devices licensed for operation in the Village, but to increase the number of operators’ licenses from twenty (20) to twenty-five (25).

NOW, THEREFORE, BE IT ORDAINED by the President and Board of Trustees of the Village of Orland Park, Cook and Will Counties, Illinois, as follows:

SECTION 1:

The above recitals are incorporated herein by reference as though fully set forth herein.

SECTION 2:

Title 7, Chapter 6, Section 2 is amended by repealing subsection (B) thereof and replacing it in its entirety as follows:

7-6-2 LICENSE; FEES; EMBLEM:

“(B) For the issuance of no more than twenty-five (25) automatic amusement device operators licenses at the fee of \$100.00 for persons, firms, corporations or associations displaying for public patronage or keeping for operation by patrons any automatic amusement devices. As part of the \$100.00 annual fee required under this subsection, each licensee shall also receive two (2) of the licenses required under subsection 2(C) below.”

SECTION 3:

This Ordinance shall be in full force and effect from and after its adoption and publication in pamphlet form as provided by law.

REQUEST FOR ACTION REPORT

File Number:	2016-0391
Orig. Department:	Development Services Department
File Name:	Sandburg High School Monument Sign

BACKGROUND:

Prior to the LaGrange widening and reconstruction project, Sandburg High School had an entry/monument sign located at the southwest corner of 131st and LaGrange Road. Additional right of way was necessary at the corner of the widening of the intersection. With the widening, the existing sign was removed. Throughout the development of the LaGrange Road enhancement plans, discussions concerning a replacement sign between the Village and the School District have been ongoing. A new sign is proposed at the southwest corner within the school district property.

The proposed sign is designed to include the same materials and aesthetic features as the other walls throughout the corridor. The wall will also include LED up-lighting. A rendering of the wall is attached for reference. The procurement and placement of the championship plaques will be the responsibility of the school district.

An Intergovernmental Agreement (IGA) between the Village and District 230 was developed. The IGA outlines the construction costs, construction responsibilities and maintenance of the proposed sign. The construction costs of the sign will be divided by the Village and District equally (50/50). The District has recently reviewed and signed the IGA.

V3 Construction Group has procured construction pricing for the installation of the sign. The construction of the new sign will cost \$158,134.73, of which the Village and the District will each pay 50% of this cost (\$79,067.36).

On June 20, 2016, this item was reviewed by the Development Services Planning and Engineering Committee, recommended for approval and referred to the Village Board of Trustees for consideration.

BUDGET IMPACT:

Funds for the Village portion of the construction have been previously approved and included in the contract with V3 Construction Group - PO 14-000968. The Village will invoice the district for their portion of the sign installation cost.

REQUESTED ACTION:

I move to approve the Intergovernmental Agreement between the Village of Orland Park and School District 230 for the installation of the new entry sign at Sandburg High School and recommend to authorize the Mayor to execute the agreement.

**CARL SANDBURG
HIGH SCHOOL**
State Championships

2010 Softball
2011 Ladies'
Basketball
2010 Softball
2010 Softball
2010 Softball
2010 Softball
2010 Softball

2010 Softball	2010 Softball	2010 Softball	2011 Ladies' Basketball
2010 Softball	2010 Softball	2010 Softball	2010 Softball
2010 Softball	2010 Softball	2010 Softball	2010 Softball
2010 Softball	2011 Ladies' Basketball	2010 Softball	2010 Softball
2010 Softball	2010 Softball	2010 Softball	2010 Softball
2010 Softball	2010 Softball	2010 Softball	2011 Ladies' Basketball
2011 Ladies' Basketball	2010 Softball	2010 Softball	2010 Softball
	2010 Softball	2010 Softball	

2010 Softball
2010 Softball
2010 Softball
2010 Softball
2010 Softball
2011 Ladies'
Basketball
2010 Softball





**BID RESULTS
CARL SANDBURG SIGN**

Item	Description	FULL SIGN	PARTIAL SIGN *
		Total	Total
1.0	CONCRETE FOUNDATION	\$ 39,805.00	\$ 29,805.00
2.0	MASONRY	\$ 102,650.00	\$ 91,800.00
3.0	LIGHTING	\$ 15,679.73	\$ 15,679.73
TOTAL SIGN COST:		\$ 158,134.73	\$ 137,284.73

* See concept for eliminating "wing walls" from the sign

Drawing name: K:\GIS\DEV\NO-DEV\LaGrange Road- From Harddrive_2015-0822\Drawings\2015_0701_CSIS_Mouvement\Plan\Landscape\Plan.dwg L1.0 SIGNAGE PLAN Dec 16, 2015 8:43pm by amanda.coble
 This document, together with the concepts and designs presented herein, is intended only for the specific purpose and client for which it was prepared. Reuse or any improper reliance on this document without written authorization and adaptation by Kimley-Horn and Associates, Inc. shall be without liability to Kimley-Horn and Associates, Inc.

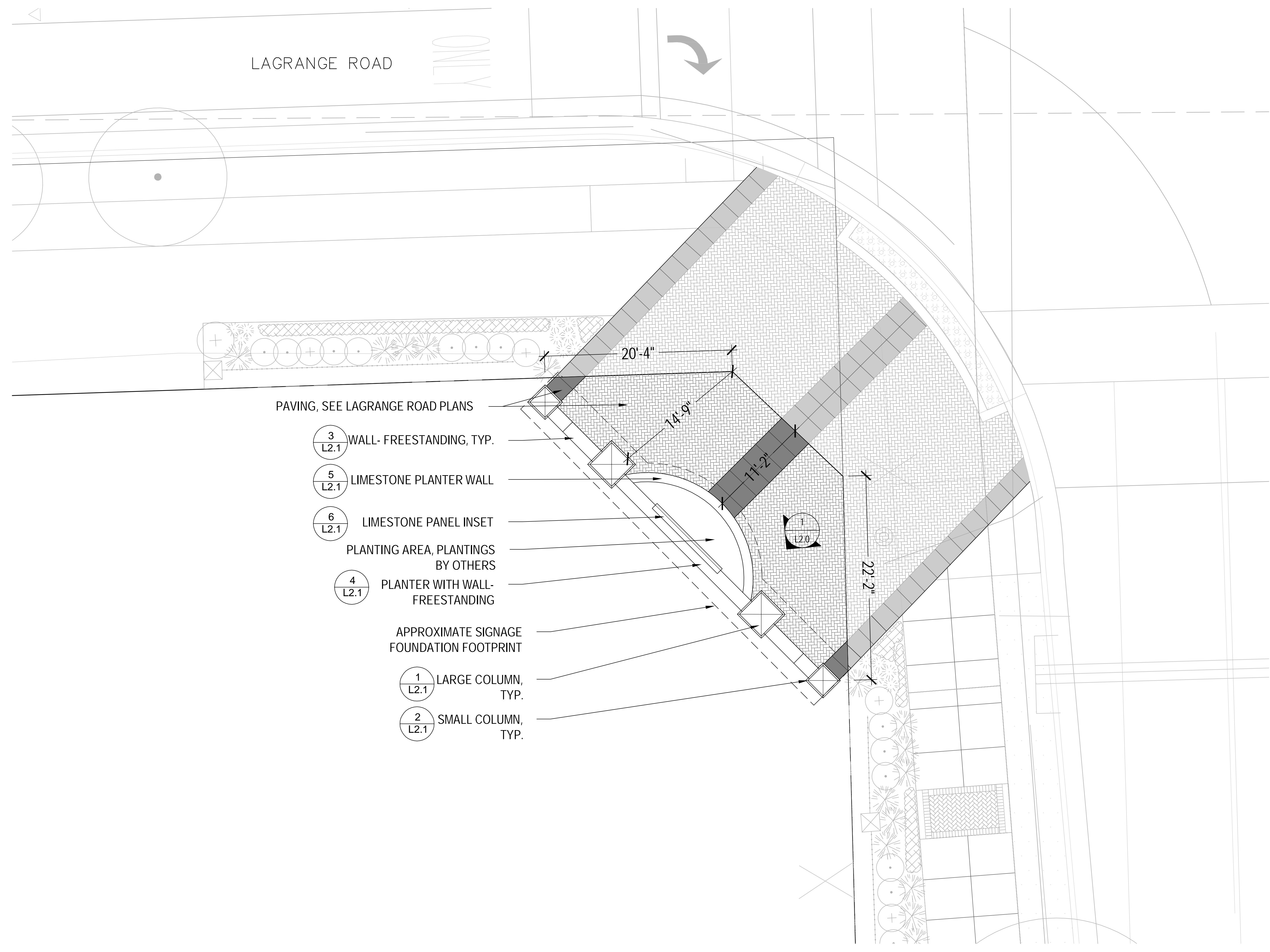

PAVING, SEE LAGRANGE ROAD PLANS

3
L2.1 WALL- FREESTANDING, TYP.

5
L2.1 LIMESTONE PLANTER WALL

6
L2.1 LIMESTONE PANEL INSET

PLANTING AREA, PLANTINGS BY OTHERS

4
L2.1 PLANTER WITH WALL-FREESTANDING

APPROXIMATE SIGNAGE FOUNDATION FOOTPRINT

1
L2.1 LARGE COLUMN, TYP.

2
L2.1 SMALL COLUMN, TYP.

		© 2015 KIMLEY-HORN AND ASSOCIATES, INC. 1001 WARRENVILLE ROAD, SUITE 300, WARRENVILLE, IL 60091 PHONE: 630-487-5550 WWW.KIMLEY-HORN.COM	
SCALE:	AS NOTED	DESIGNED BY:	KED
		DRAWN BY:	AMF
		CHECKED BY:	KED
SIGNAGE PLAN		ORIGINAL ISSUE: ###	
		KHA PROJECT NO. ###	
CARL SANDBURG HIGH SCHOOL		SHEET NUMBER L1.0	
REVISIONS		NO.	DATE
BY		DATE	

Drawing name: K:\GIS\DEV\NO-DEV\Exchange Road- From Herdvia, 2015-0823\Drawings\2015_0701_CBSIS Movement\Plan\Landscape Details.dwg L2.1 SIGNAGE DETAILS Dec 16, 2015 5:48pm by amanda.foto
 This document, together with the concepts and designs presented herein, is intended only for the specific purpose and client for which it was prepared. Reuse of and improper reliance on this document without written authorization and adaptation by Kimley-Horn and Associates, Inc. shall be without liability to Kimley-Horn and Associates, Inc.

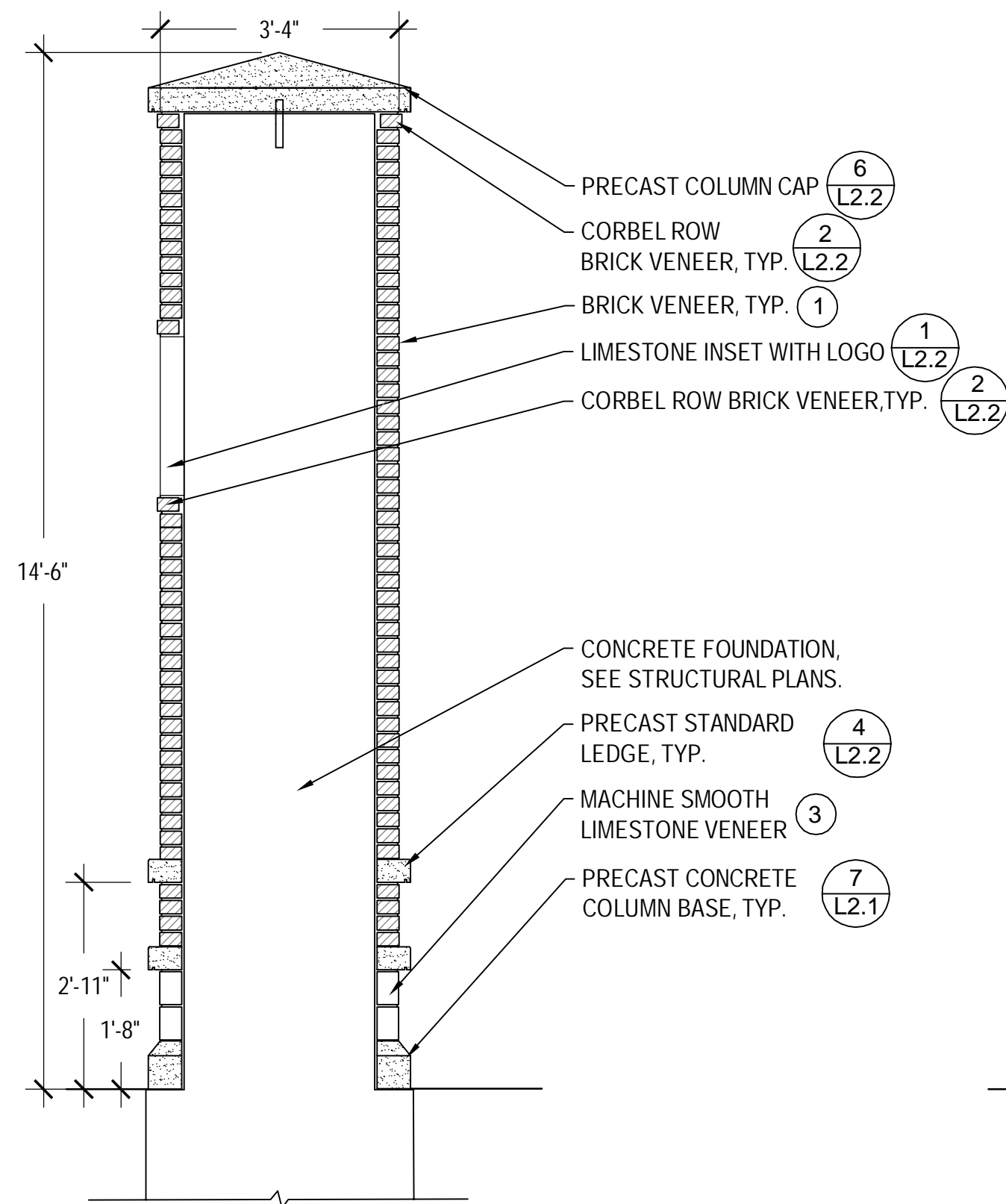

1 LARGE COLUMN

SCALE: 1/2" = 1'-0"

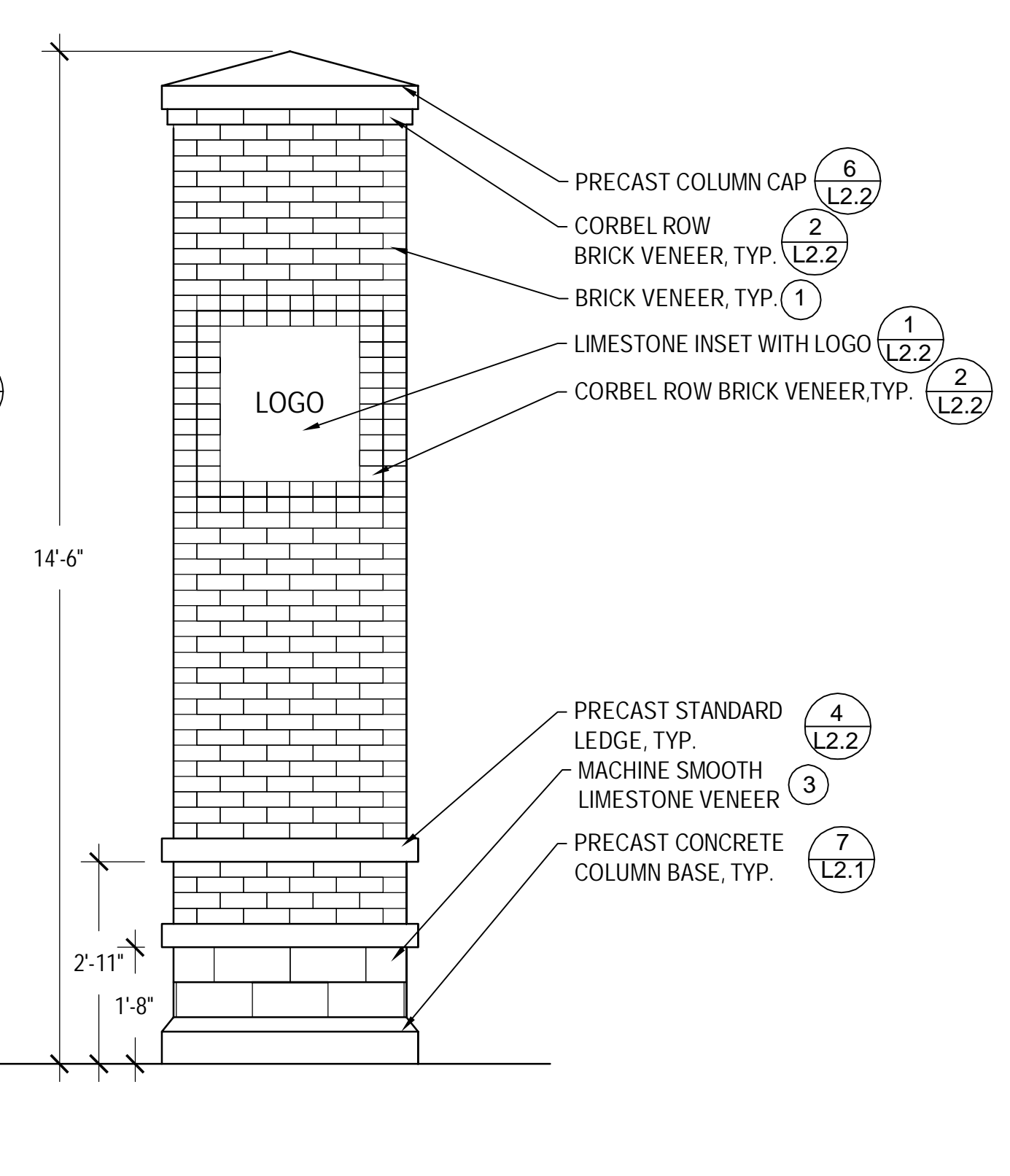

2 SMALL COLUMN

SCALE: 1/2" = 1'-0"

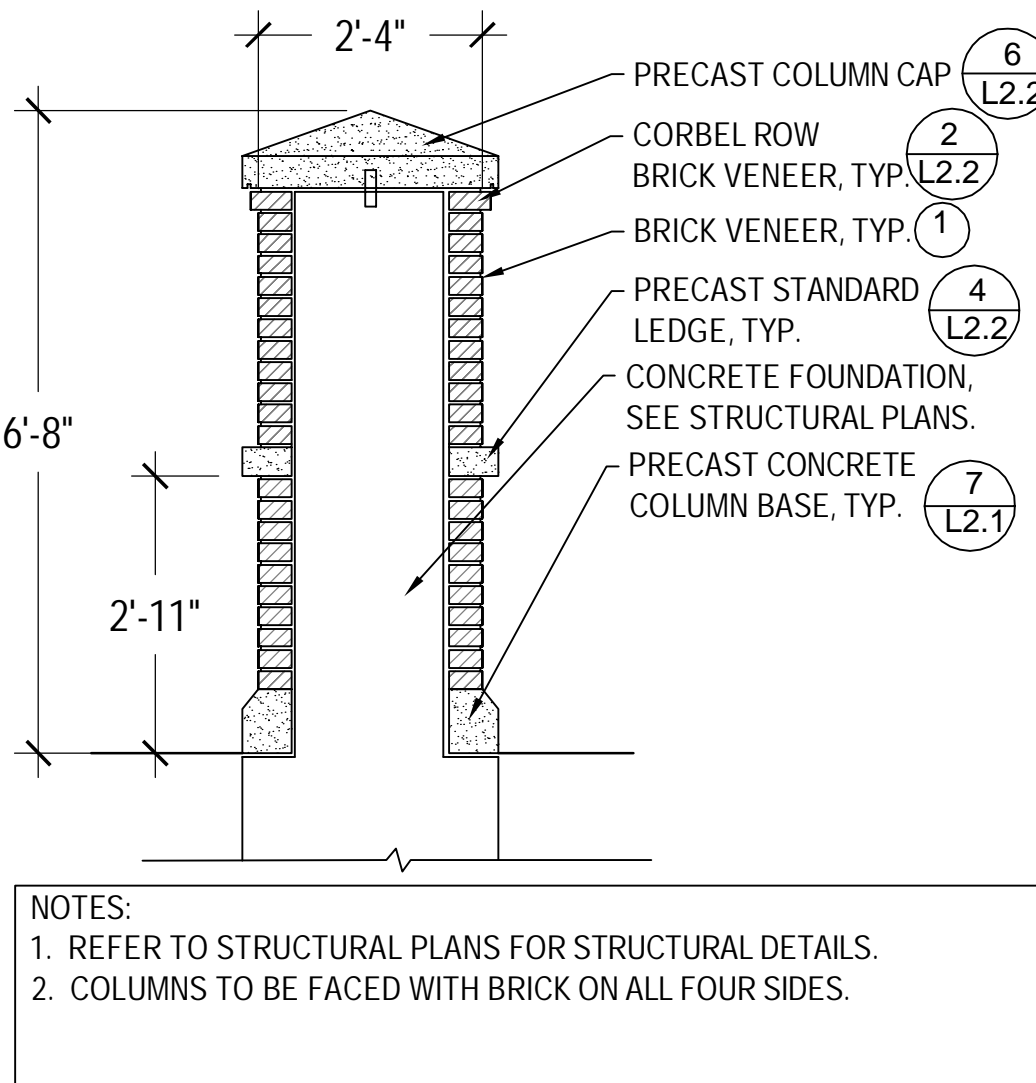

NOTES:
 1. REFER TO STRUCTURAL PLANS FOR STRUCTURAL DETAILS.
 2. COLUMNS TO BE FACED WITH BRICK ON ALL FOUR SIDES.

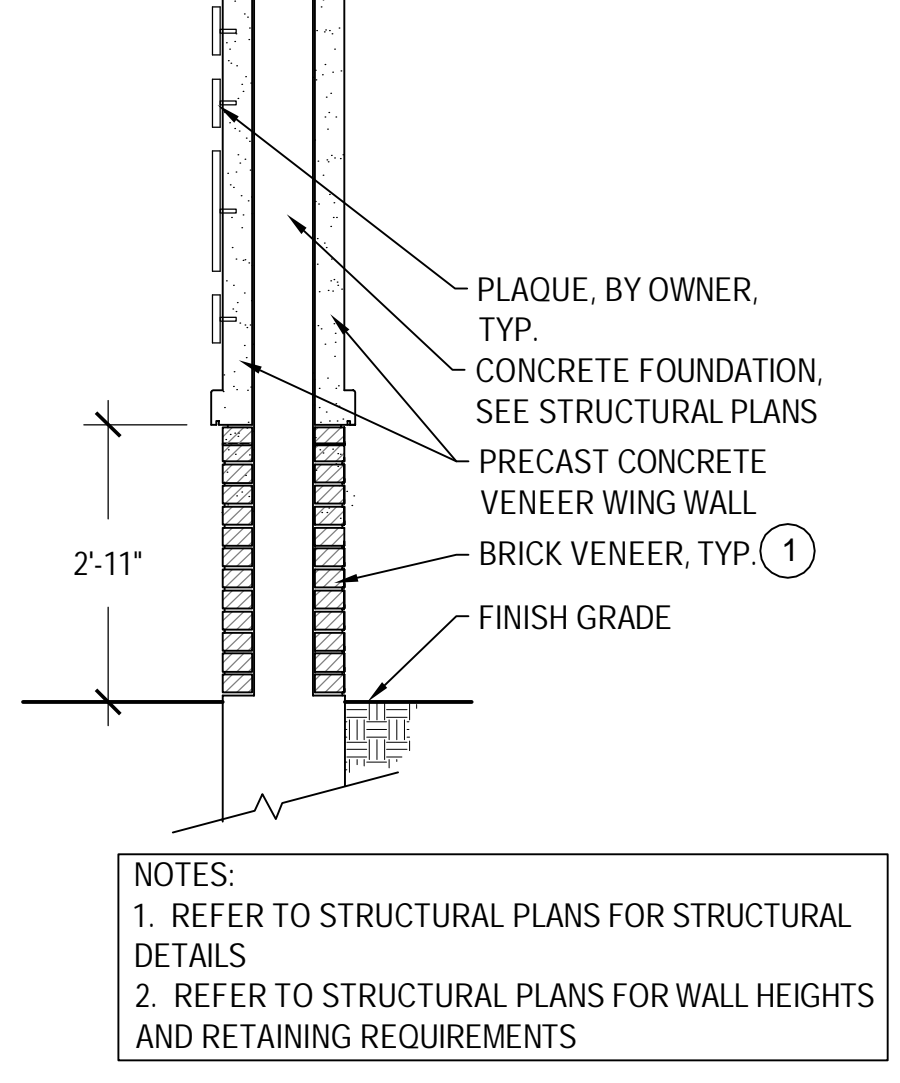
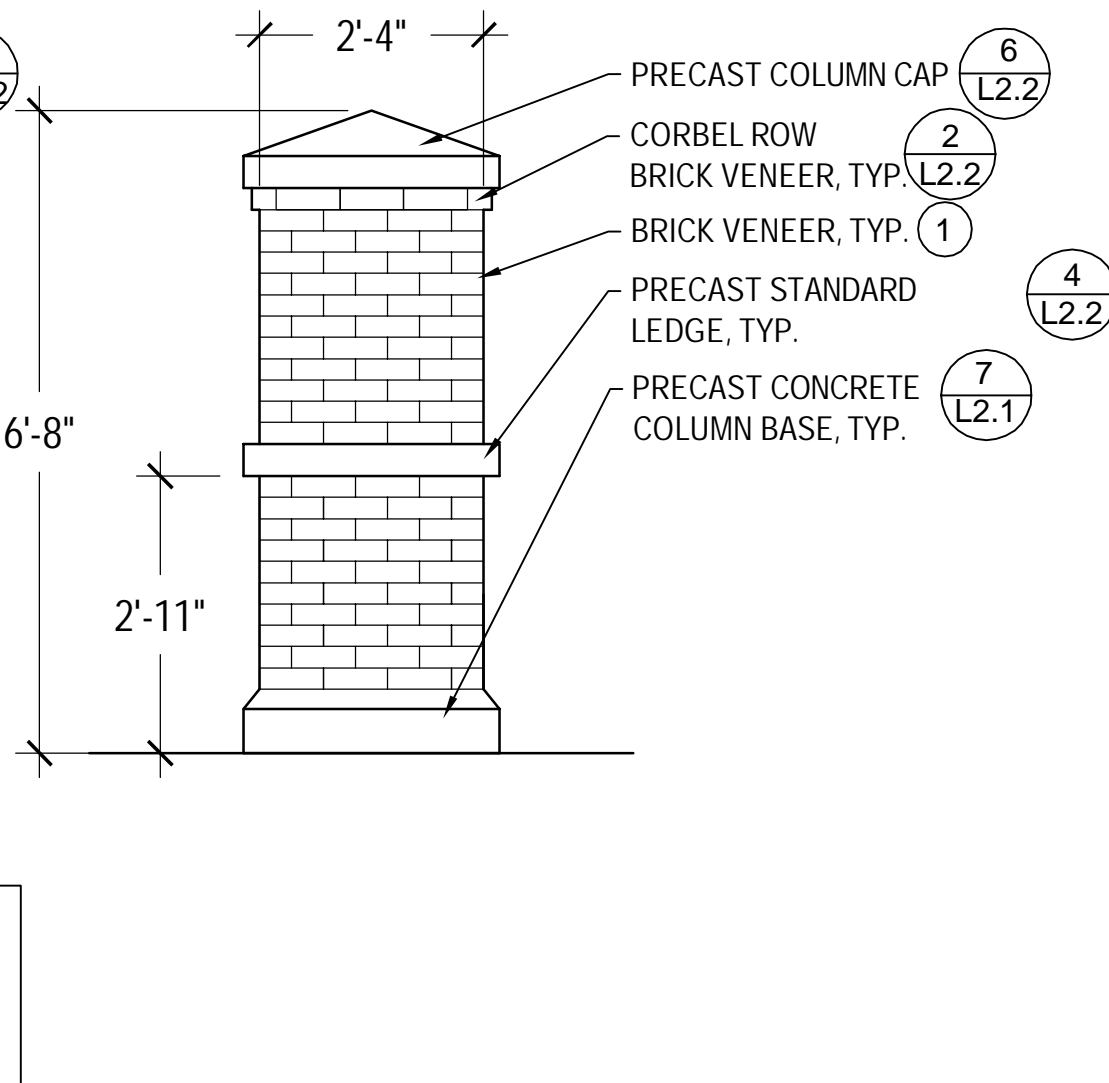

NOTES:
 1. REFER TO STRUCTURAL PLANS FOR STRUCTURAL DETAILS
 2. REFER TO STRUCTURAL PLANS FOR WALL HEIGHTS AND RETAINING REQUIREMENTS

3 WALL - FREESTANDING

SCALE: 1/2" = 1'-0"

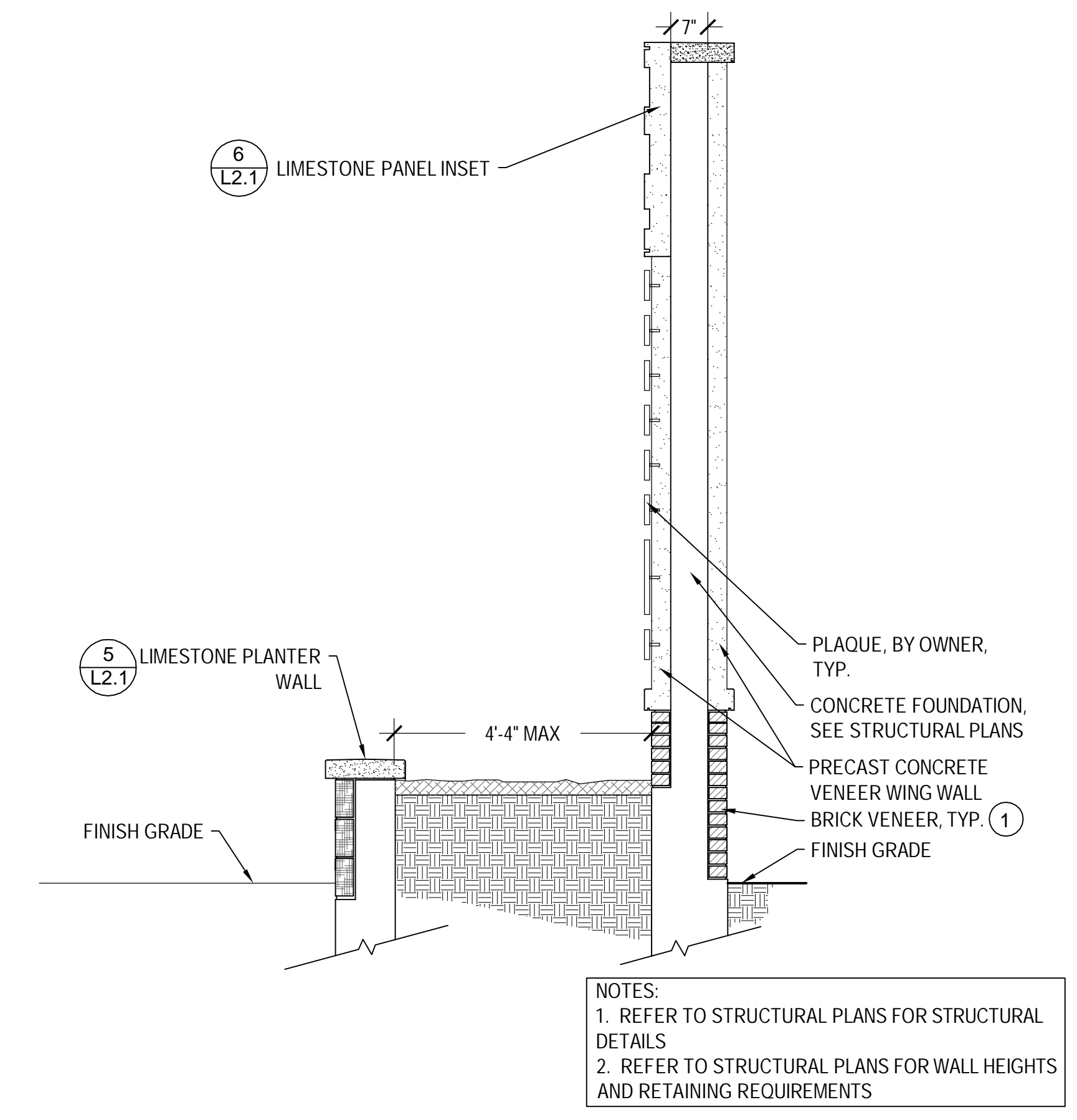

4 PLANTER WITH WALL - FREESTANDING

SCALE: 1/2" = 1'-0"

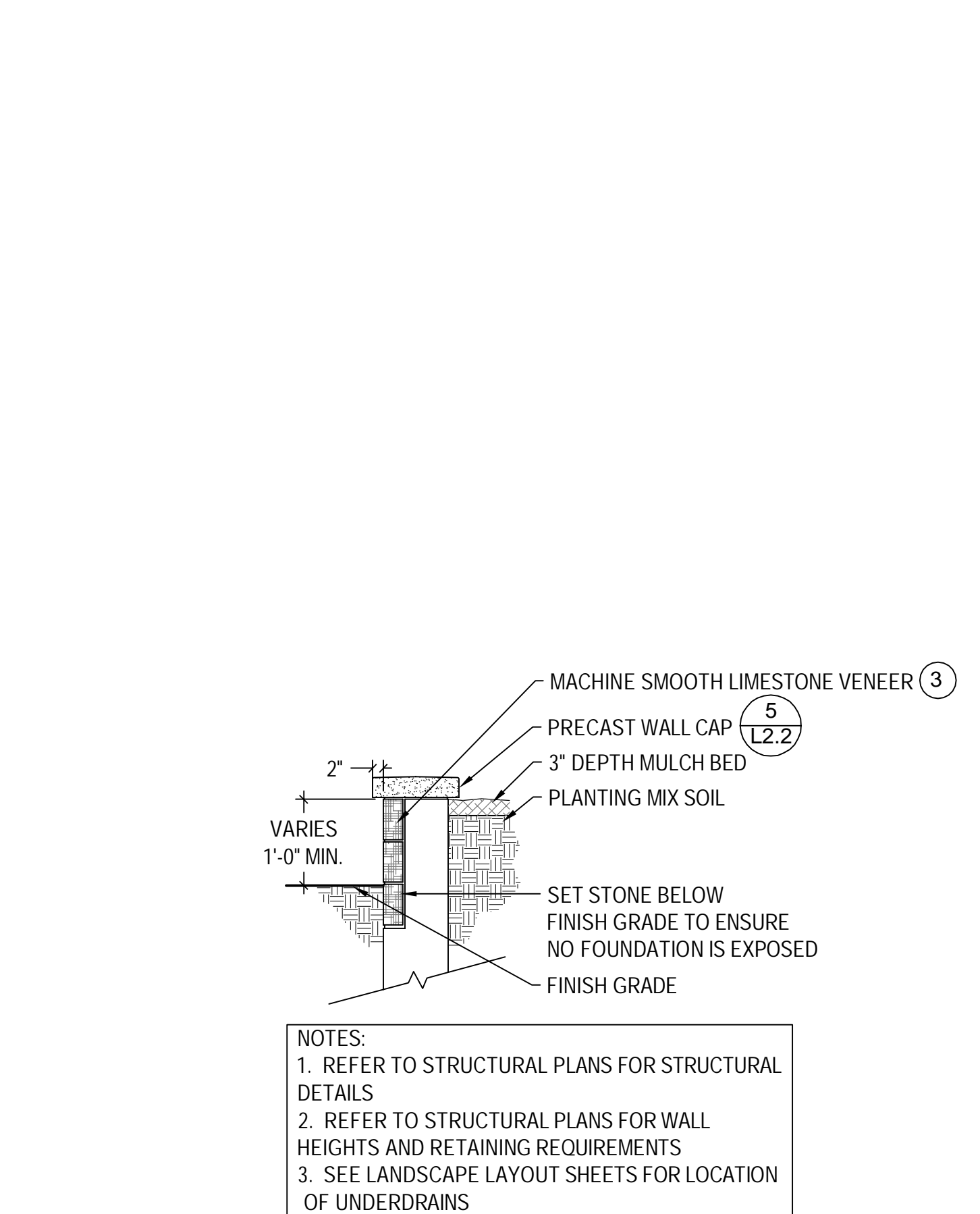

5 LIMESTONE PLANTER WALL

SCALE: 1/2" = 1'-0"

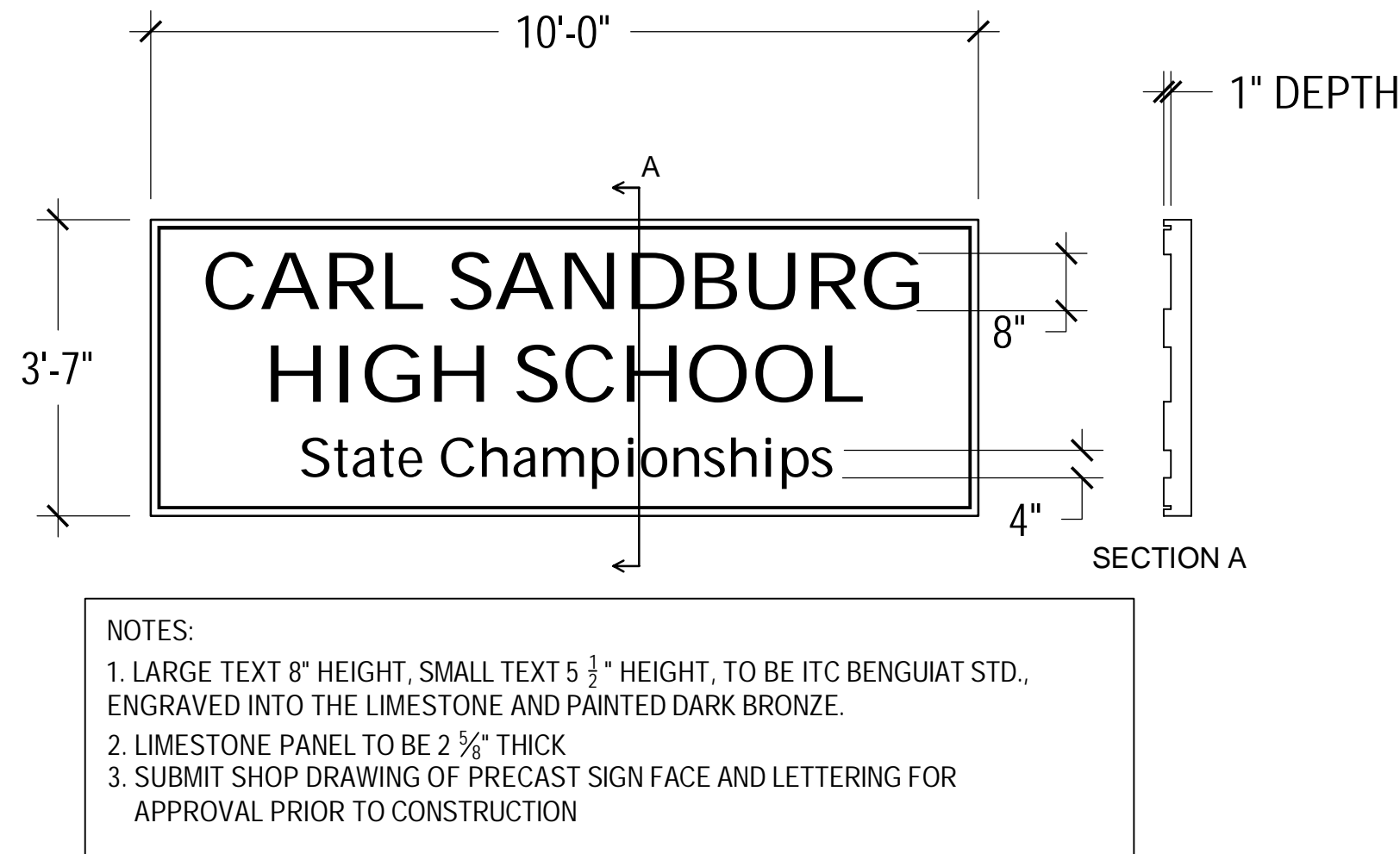

NOTES:
 1. LARGE TEXT 8" HEIGHT, SMALL TEXT 5 1/2" HEIGHT, TO BE ITC BENGUAT STD., ENGRAVED INTO THE LIMESTONE AND PAINTED DARK BRONZE.
 2. LIMESTONE PANEL TO BE 2 3/4" THICK
 3. SUBMIT SHOP DRAWING OF PRECAST SIGN FACE AND LETTERING FOR APPROVAL PRIOR TO CONSTRUCTION

6 LIMESTONE PANEL INSET

SCALE: 1/2" = 1'-0"

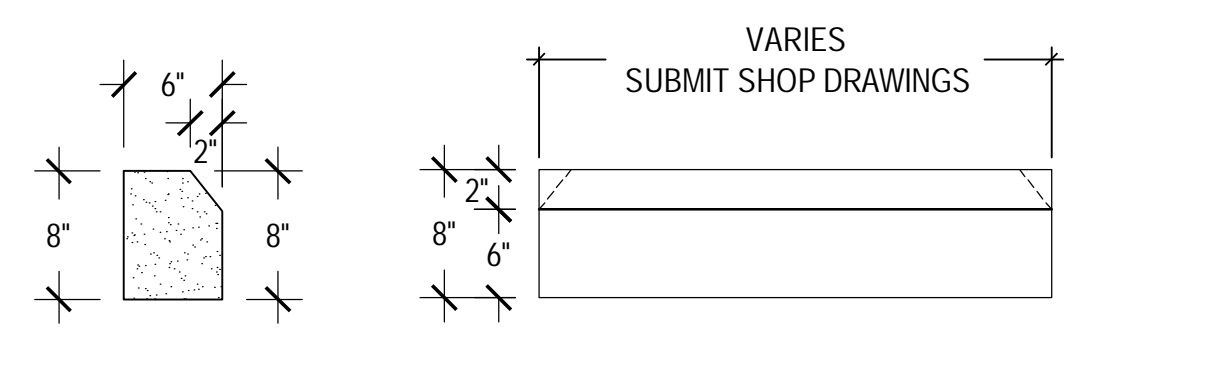

7 PRECAST CONCRETE COLUMN BASE

SCALE: 1" = 1'-0"

SIGNAGE
DETAILS

CARL SANDBURG
HIGH SCHOOL

ORIGINAL ISSUE:

KHA PROJECT NO.

SHEET NUMBER

L2.1

NO.	REVISIONS	DATE	BY

Kimley»Horn
 © 2015 KIMLEY-HORN AND ASSOCIATES, INC.
 1001 WARRENVILLE ROAD, SUITE 350,
 WARRENVILLE, IL 60067
 PHONE: 630-487-5550
 WWW.KIMLEY-HORN.COM

SCALE: AS NOTED
 DESIGNED BY: KED
 DRAWN BY: AMF
 CHECKED BY: KED

Drawing name: K:\GIS\DEV\ND-DEV\LeBron-Road-Front-Header-2015-0823\Drawings\2015_0701_CSIS_Monument\Plan\Landscape\Details.dwg L3.2_SIGNAGE_DETAILS Dec 16, 2015 5:36pm by: amanda.foto
 This document, together with the concepts and designs presented herein, is intended only for the specific purpose and client for which it was prepared. Reuse or improper reliance on this document without written authorization and adaptation by Kimley-Horn and Associates, Inc. shall be without liability to Kimley-Horn and Associates, Inc.

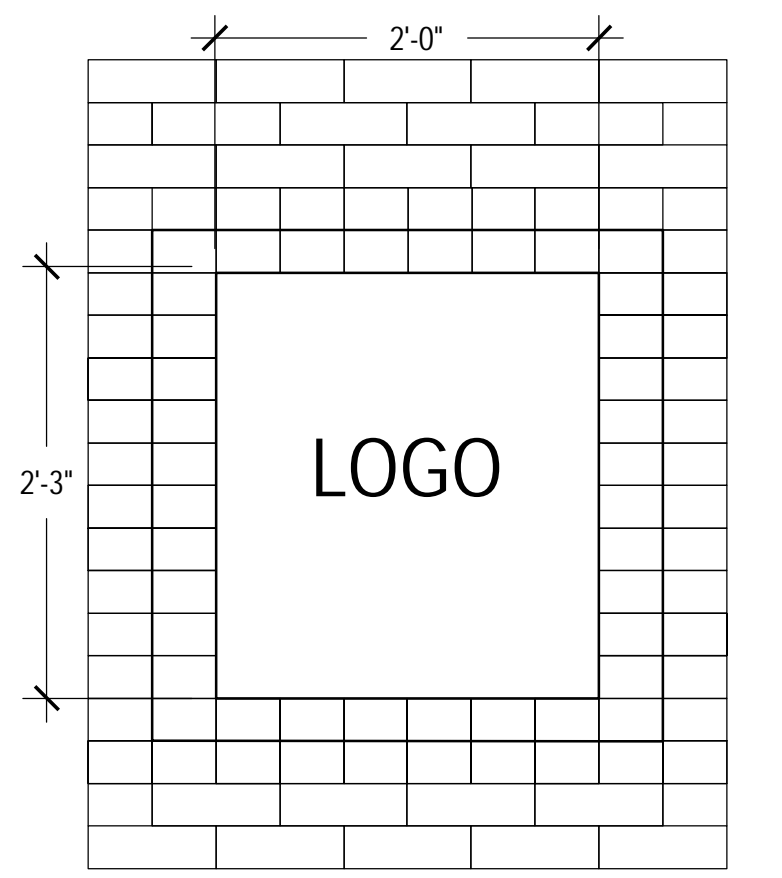

NOTES:
 1. FINAL LOGO TO BE APPROVED BY OWNER
 2. COLORED CONCRETE INSET TO MATCH CAPS
 3. ETCHED/STAMPED LOGO IN CONCRETE
 SUBMIT SHOP DRAWING FOR APPROVAL
 PRIOR TO CONSTRUCTION

1 LIMESTONE INSET WITH LOGO
 SCALE: 1" = 1'-0"

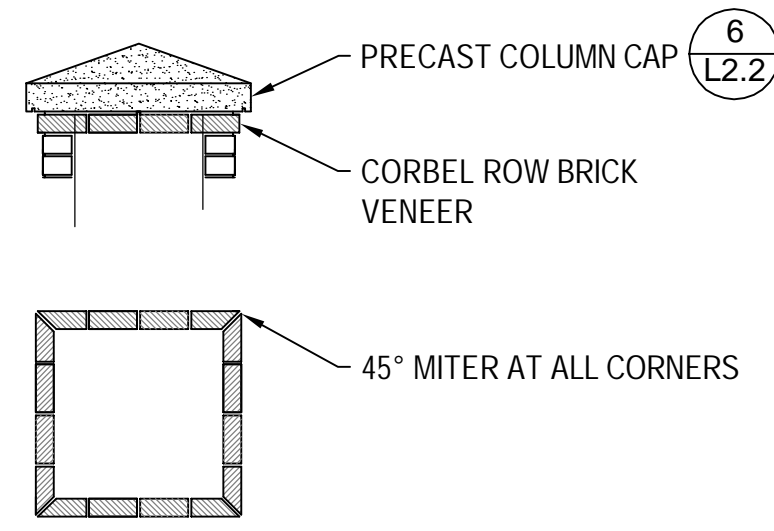

2 CORBEL ROW DETAIL
 SCALE: NTS

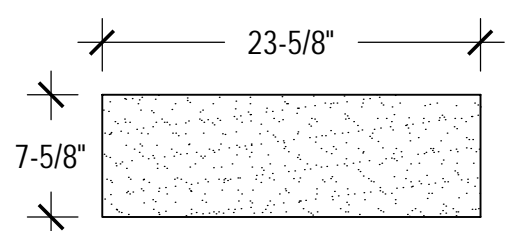

NOTES:
 1. DEPTH OF PRECAST VENEER BLOCK
 SHALL BE THE SAME AS THE BRICK. 3'-5/8"
 2. MITER CORNERS

3 PRECAST CONCRETE VENEER BLOCK
 SCALE: 1" = 1'-0"

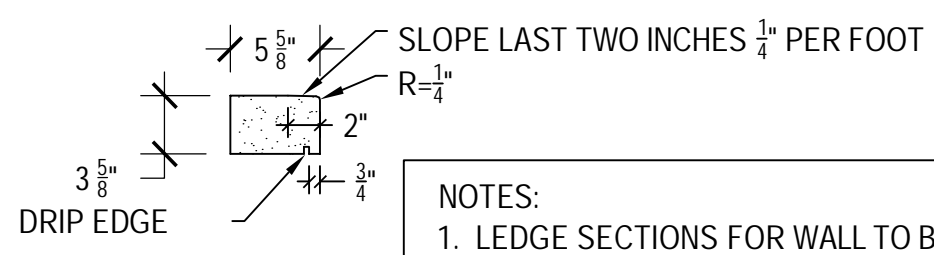

NOTES:
 1. LEDGE SECTIONS FOR WALL TO BE 36" LONG
 2. MITER INSIDE AND OUTSIDE CORNERS

4 PRECAST STANDARD LEDGE
 SCALE: 1" = 1'-0"

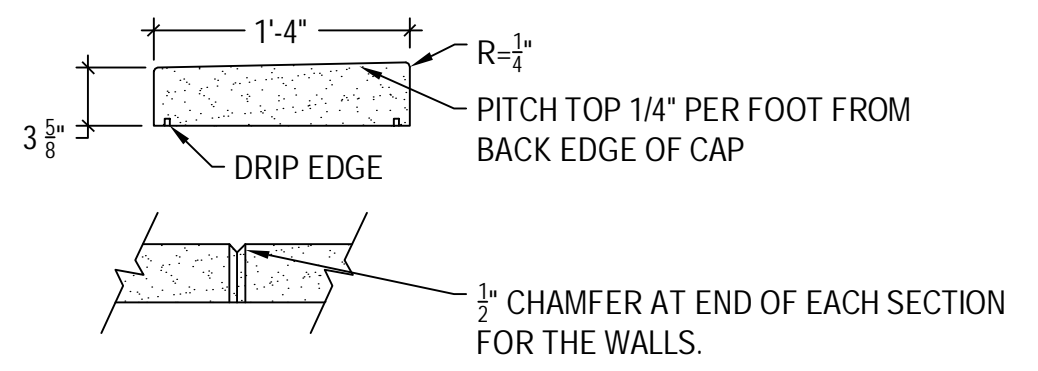

NOTES:
 1. CAP SECTIONS TO BE 48" LONG
 2. MITER INSIDE AND OUTSIDE CORNERS

5 PRIMARY MONUMENT PRECAST WALL CAP
 SCALE: 1" = 1'-0"

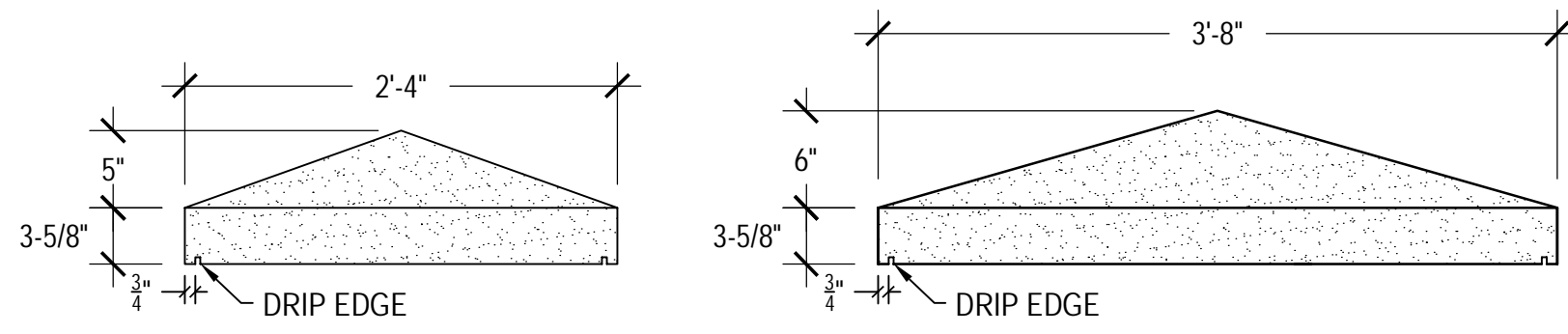

6 PRECAST COLUMN CAP
 SCALE: 1" = 1'-0"

ORIGINAL ISSUE: ###	
KHA PROJECT NO. ###	
SHEET NUMBER L2.2	
SCALE: AS NOTED DESIGNED BY: KED DRAWN BY: AMF CHECKED BY: KED	Kimley»Horn © 2015 KIMLEY-HORN AND ASSOCIATES, INC. 1001 WARRENVILLE ROAD, SUITE 300, WARRENVILLE, OHIO 45166 PHONE: 631-487-5550 WWW.KIMLEY-HORN.COM
SIGNAGE DETAILS	CARL SANDBURG HIGH SCHOOL
NO.	REVISIONS
DATE	BY

INTERGOVERNMENTAL AGREEMENT

This Intergovernmental Agreement (the "Agreement") is executed on the date last written below, by and between the VILLAGE OF ORLAND PARK (the "Village") and the BOARD OF EDUCATION OF CONSOLIDATED HIGH SCHOOL DISTRICT 230 ("the District"), and collectively with the Board, the "Parties").

RECITALS

- A. The Village is an Illinois home rule municipal corporation;
- B. The District is a School District created under the laws of the State of Illinois, and the Parties are authorized by Article VII, Section 10 of the Constitution of the State of Illinois of 1970, by the Intergovernmental Cooperation Act, 5 ILCS 220/1, *et seq.*, and by their respective enabling statutes, to enter into and perform this Agreement.
- C. The Parties have agreed to cooperate with each other in making provisions for the installation, operation and maintenance of an outdoor "Carl Sandburg High School" identification sign ("Sign") to be located at the southwest corner of 131st Street and LaGrange Road (U.S. Route 45) on the site of the District's Carl Sandburg High School ("Sign Location"). Detailed specifications and depictions of the Sign prepared by KIMLEY-HORN AND ASSOCIATES, INC. are attached as Group Exhibit A.

NOW THEREFORE, in consideration of these recitals and the terms and conditions of this Agreement, and other good and valuable consideration, the sufficiency of which is hereby acknowledged by the Parties, the Parties agree as follows:

1. **Incorporation of Recitals.** The above recitals are incorporated into this Agreement.
2. **Installation of Sign.** The District hereby grants the Village and its authorized contractors authorization to construct and install the Sign at the Sign Location. The District shall give the Village access to the Sign Location during this initial installation and from time to time as reasonably necessary to perform this Agreement. The Village shall be responsible for the competitive bidding and installation of the Sign under this Agreement. The Sign shall be electrically illuminated, and the District, as a part of the construction and installation of the Sign, shall cause adequate electric service to be brought to the Sign Location.
3. **Construction and Installation Cost.** Except for the cost of bringing electric service to the Sign Location, which cost is to be borne solely by the District, the cost of construction and installation of the Sign shall be borne equally by the District and the Village.
4. **Additional Post-Construction Costs.** The purchase and placement of adornments to the Sign (such as school athletic championship plaques) shall be at the sole cost of the District.

5. **Operation and Maintenance of the Sign.** Following construction and installation of the Sign, the District shall thereafter be fully and solely responsible for the operation, maintenance, repair, replacement or reconstruction of the Sign, and the District shall at all times be the owner of the Sign.

6. **Indemnity.** Each Party shall indemnify, defend, and hold harmless the other Party from all claims, demands, causes of action, losses, liabilities, damages, penalties, fines, and expenses, including reasonable attorney's fees and court costs, which are incurred by the other Party, but only to the extent arising from the indemnifying Party's negligent or intentional act or omission, or from the indemnifying Party's breach of this Agreement. The obligations contained in this Section shall not apply to the extent the indemnifying Party has tort immunity for the underlying claim.

7. **No Third Party Beneficiary.** This Agreement is not intended to confer any right upon any third party who is not a Party to this Agreement.

8. **No Assignment or Delegation.** Each Party represents and warrants that it has not and will not assign any rights or delegate any duties arising from this Agreement.

9. **Advice of Counsel and Understanding of Agreement.** The Parties each understand their right to discuss all aspects of this Agreement with their legal counsel, and have done so if desired. The Parties acknowledge that they have carefully read and fully understand all provisions of this Agreement.

10. **Choice of Law.** This Agreement shall be governed by, subject to, and construed in accordance with the laws of the State of Illinois without regard to conflict of law principles. Venue for any dispute arising under this Agreement shall be in Cook County, Illinois.

11. **Binding Effect and Interpretation.** The Parties intend this Agreement to be legally binding. This Agreement shall bind and inure to the benefit of the Parties and their legal representatives, successors and assigns. The provisions of this Agreement are severable and no provision shall be affected by the invalidity of any other provision. This Agreement has been jointly drafted by the Parties, and in the event any court determines any provision of this Agreement to be ambiguous, the ambiguity shall not be construed against either Party.

12. **Execution in Counterparts.** This Agreement may be executed in counterparts. When both counterparts have been executed by both Parties and exchanged with the other Party, electronically or in hardcopy, this Agreement shall be deemed fully-executed and binding as if both Parties had signed and exchanged the same originals.

13. **Integration.** This Agreement contains the entire agreement between the Parties and supersedes all prior agreements between the Parties, both oral and written, concerning any subject matter referenced in this Agreement. This Agreement may only be modified or cancelled by a subsequent writing executed by both Parties.

14. **Authority to Execute.** Each of the undersigned signatories represents in his/her individual capacity that he/she has actual authority to execute this Agreement on behalf of the Party represented.

Executed on the date last written below, by and between:

VILLAGE OF ORLAND PARK

**THE BOARD OF EDUCATION
CONSOLIDATED HIGH SCHOOL
DISTRICT 230**

By: _____

By: Richard J. Nozal

Title: _____

Title: President

Date: _____

Date: 4-28-16

REQUEST FOR ACTION REPORT

File Number: **2016-0455**
Orig. Department: **Development Services Department**
File Name: **Amusement Device Operators Licenses - Removal & Addition**

BACKGROUND:

Six (6) previously issued Amusement Device Operators Licenses are no longer in use and will be removed from the roster of active Amusement Device Operator Licenses and canceled. They are as follows: Cici's Pizza, Red Robin, Palos Country Club, White Mountain Golf, Jewel (located at 9350 159th Street) and Riviera Country Club. In the future, should these businesses seek an Amusement Device Operator License, they will need to reapply.

In addition, seven (7) applications for Amusement Device Operators Licenses have been submitted on behalf of the following businesses: Fattie's Pub, Gizmos Fun Factory, Twin Peaks Restaurant, Denny's, Toys R Us, Jewel (located at 17940 Wolf Road) and Babies R Us.

With the addition of 5 Amusement Device Operators Licenses to the Village Code Section 7-6-2 (B), that will bring the total maximum number of licenses to 25. The removal of six (6) licenses and the addition of seven (7) licenses will bring the total to twenty-one (21) currently active Amusement Device Operators Licenses.

On June 20, 2016, this item was reviewed by the Development Services Planning and Engineering Committee, recommended for approval and referred to the Village Board of Trustees for consideration.

BUDGET IMPACT:

REQUESTED ACTION:

I move to approve the removal of the 6 and the issuance of the 7 Automatic Amusement Device Operators Licenses. Amusement devices shall be installed meeting Village of Orland Park Codes.

Babies R Us



VILLAGE OF ORLAND PARK

Development Services Department

14700 S. Ravinia Avenue

Orland Park, IL 60462

Phone - (708) 403-5300 Fax (708) 403-6215

www.orland-park.il.us

Amusement Device Operator's License

1. Submit fully completed application. Make sure that the games are each listed along with description and serial number. Include rating as per attached AAMA Game Ratings. AAMA Game Ratings will be verified at the following website:
<http://www.coin-op.org/Games%20Rating%20List.htm>
2. Have application notarized.
3. Include check for application fee. Fee is \$50.00 per machine, minimum being \$100.00. (Covers 2 machines)
4. Submit drawing showing location of machines and distance to surrounding objects. Show doorways in room.
5. Application needs to be approved by the Village Board of Trustees. It is highly recommended that someone from your business establishment be present at the Board Meeting to answer questions.

Please read the enclosed copies of the Amusement Device Ordinances, Title 7, Chapter 5 of the Orland Park Village Code. Pay particular notice to ALL restrictions. Sign below to indicate receipt of said code and to acknowledge that you have read it in it's entirety.

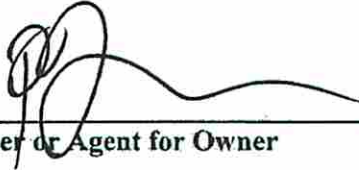

Owner or Agent for Owner

6/1/16

Date

VILLAGE OF ORLAND PARK

14700 RAVINIA AVENUE

ORLAND PARK, IL 60462

Phone (708) 403-5300 Fax (708) 403-6215

APPLICATION FOR AUTOMATIC AMUSEMENT DEVICE OPERATORS LICENSE

Please Note:

Any misrepresentation or falsification of the information sought below may result in revocation of the license as granted. You must be 21 years of age or older and be a U. S Citizen to apply. Any license issued as a result of this application shall terminate next December 31st.

Name of Business National Entertainment Network LLC Business Phone (303) 444-2559

Business Address 325 Interlocken Pkwy B; Broomfield, CO 80021

Names and Addresses of Principal Owners

Edward R Flaherty - CEO/President - 325 Interlocken Parkway B; Broomfield, CO 80021-8043

Peter Jacobson - CFO - 325 Interlocken Parkway B; Broomfield, CO 80021-8043

Address of premises where amusement devices are to be operated (if different from business address).

Babies R Us #9248 - 15820 South 94th Ave

Type of Business Coin-Operated Amusement Devices

Corporation/Association/Partnership

Names and Addresses of Principal Officers or of all Shareholders over 5%.

NEN MCP Holdings, LL - Sole Member - 325 Interlocken Parkway B; Broomfield, CO 80021-8043

Have any of the above been convicted of gambling, tax evasion, any felony, or been denied a liquor license?

None

Corporate Purpose _____

Corporate Recording Number (s) _____

Registered Agent _____

	Trade Name of Device/ Serial Number	Manufacturer	Description	Game Rating Code Color
1.	<u>CR Toy RBC 60</u> <u>129591</u>	<u>Rainbow Crane</u>	<u>60" Toy Crane</u>	
2.	<u>Kiddie Ride Prem</u> <u>10019301</u>	<u>Kiddie World</u>	<u>Jay Jay Airplane</u>	
3.				
4.				
5.				
6.				
7.				

(Additional information can be added using attached sheet)

Total Fees: \$ 100.00

Has a liquor license been issued or applied for? If so, when?

This application is for the machines as listed above. Any changes in the status of those machines will necessitate a new application.



 Owner/Agent for Owner

SUBSCRIBED AND SWORN TO
 Before me this 1st
 Day of June 2016



 Notary Public



Babies R Us #9248
15820 South 94th Ave

Store

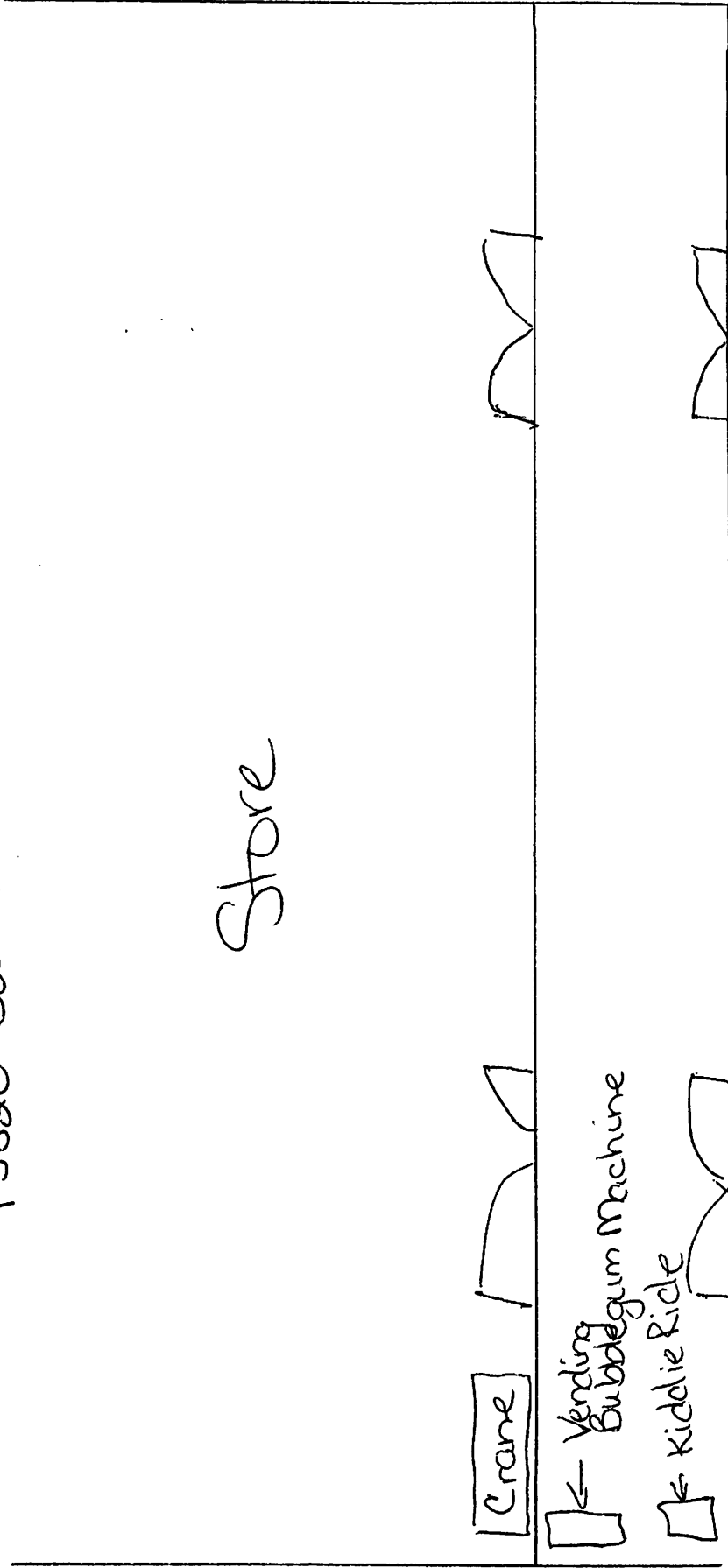

Crane

← Vending
Bubblegum Machine

← Kiddie Ride

Exit

Entrance

Denny's

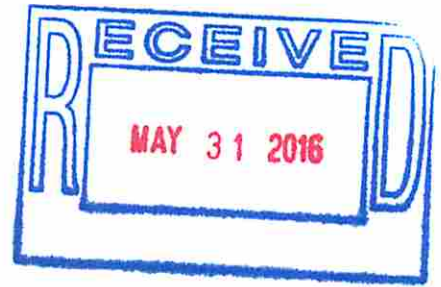

VILLAGE OF ORLAND PARK
Development Services Department
14700 S. Ravinia Avenue
Orland Park, IL 60462

Phone - (708) 403-5300 Fax (708) 403-6215
www.orland-park.il.us

Amusement Device Operator's License

1. Submit fully completed application. Make sure that the games are each listed along with description and serial number. Include rating as per attached AAMA Game Ratings. AAMA Game Ratings will be verified at the following website: <http://www.coin-op.org/Games%20Rating%20List.htm>
2. Have application notarized.
3. Include check for application fee. Fee is \$50.00 per machine, minimum being \$100.00. (Covers 2 machines)
4. Submit drawing showing location of machines and distance to surrounding objects. Show doorways in room.
5. Application needs to be approved by the Village Board of Trustees. It is highly recommended that someone from your business establishment be present at the Board Meeting to answer questions.

Please read the enclosed copies of the Amusement Device Ordinances, Title 7, Chapter 5 of the Orland Park Village Code. Pay particular notice to ALL restrictions. Sign below to indicate receipt of said code and to acknowledge that you have read it in its entirety.

Owner or Agent for Owner

5/27/16
Date



2

RECEIVED
MAY 21 2018
J. G. YAM

VILLAGE OF ORLAND PARK

14700 RAVINIA AVENUE
ORLAND PARK, IL 60462

Phone (708) 403-5300 Fax (708) 403-6215

APPLICATION FOR AUTOMATIC AMUSEMENT DEVICE OPERATORS LICENSE

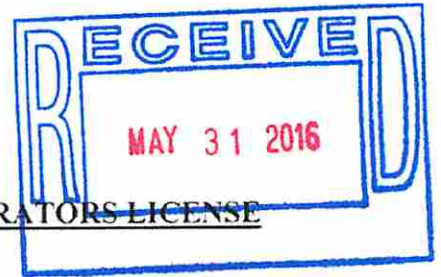

Please Note:

Any misrepresentation or falsification of the information sought below may result in revocation of the license as granted. You must be 21 years of age or older and be a U. S Citizen to apply. Any license issued as a result of this application shall terminate next December 31st.

Name of Business National Entertainment Network LLC Business Phone (303) 444-2559

Business Address 325 Interlocken Pkwy B; Broomfield, CO 80021

Names and Addresses of Principal Owners

Edward R Flaherty - CEO/President - 325 Interlocken Parkway B; Broomfield, CO 80021-8043

Peter Jacobson - CFO - 325 Interlocken Parkway B; Broomfield, CO 80021-8043

Address of premises where amusement devices are to be operated (if different from business address).

Denny's #8821 - #21 Orland Square Dr; Orland Park, IL

Type of Business Coin-Operated Amusement Devices

Corporation/Association/Partnership

Names and Addresses of Principal Officers or of all Shareholders over 5%.

NEN MCP Holdings, LL - Sole Member - 325 Interlocken Parkway B; Broomfield, CO 80021-8043

Have any of the above been convicted of gambling, tax evasion, any felony, or been denied a liquor license?

None

Corporate Purpose _____

Corporate Recording Number (s) _____

Registered Agent CT Corporation System - 208 South LaSalle St, Suite 814

Chicago, IL 60604

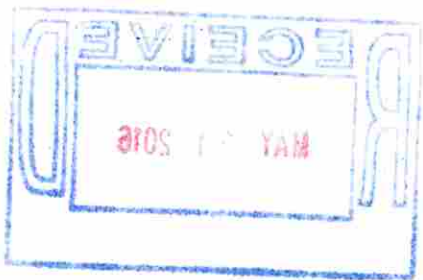

2000

1000

	Trade Name of Device/ Serial Number	Manufacturer	Description	Game Rating Code Color
1.	C HV SMT 31 T-58831	SMART	31" Other Crane	MAY 31 2016
2.	CR Toy RBC 42 120673	Rainbow Crane	42" Toy Crane	
3.				
4.				
5.				
6.				
7.				

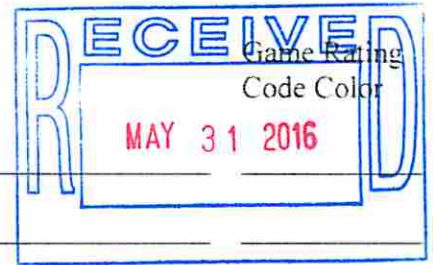

(Additional information can be added using attached sheet)

Total Fees: \$ 100.00

Has a liquor license been issued or applied for? If so, when?

N/A

This application is for the machines as listed above. Any changes in the status of those machines will necessitate a new application.

SONIA L. ASHMORE
Notary Public
State of Colorado

[Signature]

Owner/Agent for Owner

SUBSCRIBED AND SWORN TO

Before me this 27th
Day of May 20 15

[Signature]
Notary Public

ID # 19934015595

My Commission expires 04/17/2017

Dennys #8821 Orlando Park, IL
 20 Orland Square Dr

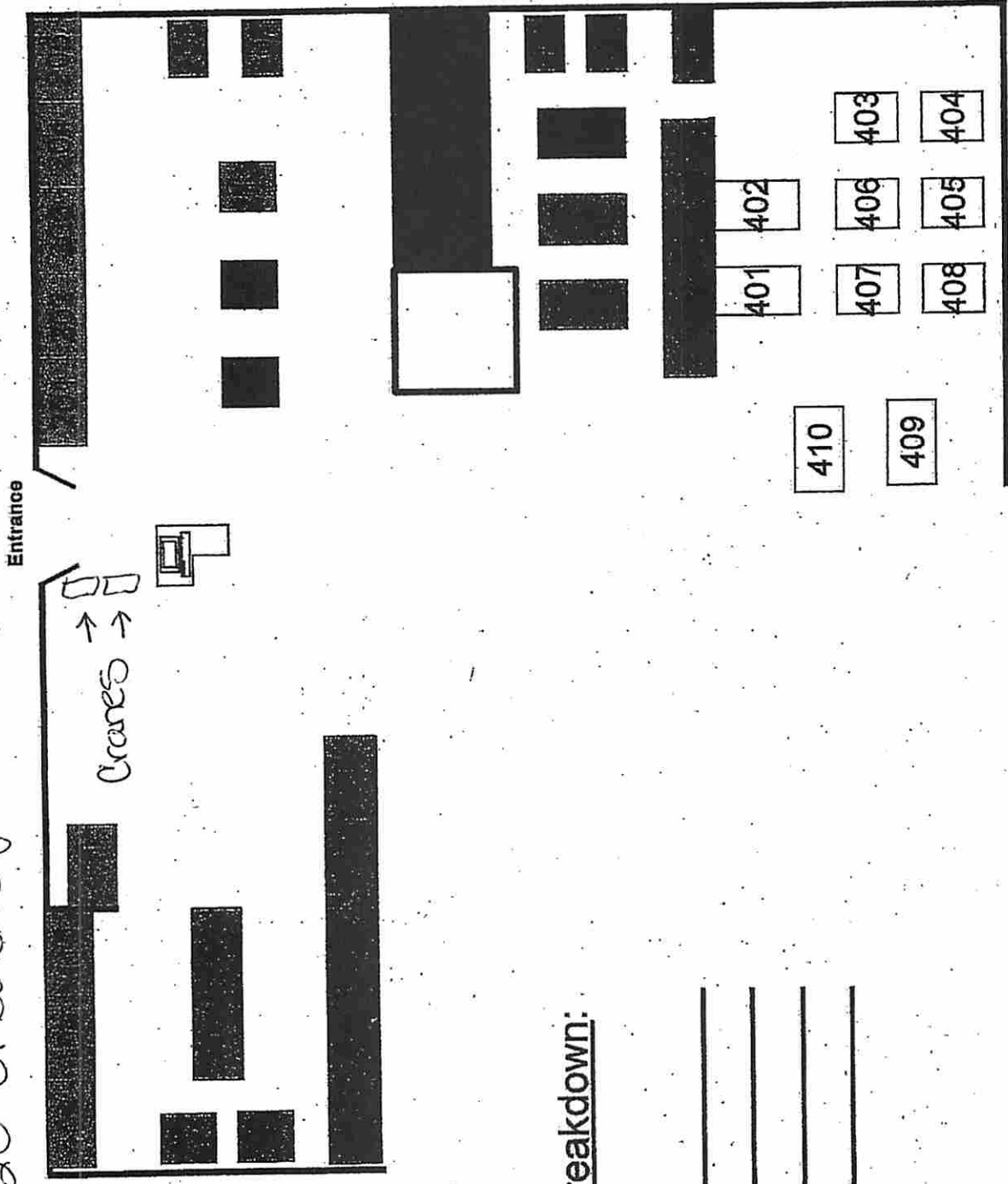
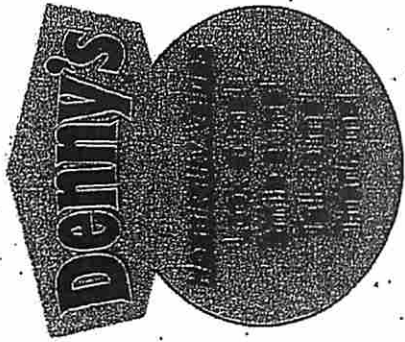

4 Station Breakdown:

Four horizontal lines for writing, positioned below the "Station Breakdown:" label.

Jewel
17930 Wolf Rd



VILLAGE OF ORLAND PARK
Development Services Department
14700 S. Ravinia Avenue
Orland Park, IL 60462

Phone - (708) 403-5300 Fax (708) 403-6215
www.orland-park.il.us

Amusement Device Operator's License

1. Submit fully completed application. Make sure that the games are each listed along with description and serial number. Include rating as per attached AAMA Game Ratings. AAMA Game Ratings will be verified at the following website:
<http://www.coin-op.org/Games%20Rating%20List.htm>
2. Have application notarized.
3. Include check for application fee. Fee is \$50.00 per machine, minimum being \$100.00. (Covers 2 machines)
4. Submit drawing showing location of machines and distance to surrounding objects. Show doorways in room.
5. Application needs to be approved by the Village Board of Trustees. It is highly recommended that someone from your business establishment be present at the Board Meeting to answer questions.

Please read the enclosed copies of the Amusement Device Ordinances, Title 7, Chapter 5 of the Orland Park Village Code. Pay particular notice to ALL restrictions. Sign below to indicate receipt of said code and to acknowledge that you have read it in its entirety.



Owner or Agent for Owner

6/11/16

Date

VILLAGE OF ORLAND PARK

14700 RAVINIA AVENUE

ORLAND PARK, IL 60462

Phone (708) 403-5300 Fax (708) 403-6215

APPLICATION FOR AUTOMATIC AMUSEMENT DEVICE OPERATORS LICENSE

Please Note:

Any misrepresentation or falsification of the information sought below may result in revocation of the license as granted. You must be 21 years of age or older and be a U. S Citizen to apply. Any license issued as a result of this application shall terminate next December 31st.

Name of Business National Entertainment Network LLC Business Phone (303) 444-2559

Business Address 325 Interlocken Pkwy B; Broomfield, CO 80021

Names and Addresses of Principal Owners

Edward R Flaherty - CEO/President - 325 Interlocken Parkway B; Broomfield, CO 80021-8043

Peter Jacobson - CFO - 325 Interlocken Parkway B; Broomfield, CO 80021-8043

Address of premises where amusement devices are to be operated (if different from business address).

Jewel #3192 - 17930 South Wolf Rd

Type of Business Coin-Operated Amusement Devices

Corporation/Association/Partnership

Names and Addresses of Principal Officers or of all Shareholders over 5%.

NEN MCP Holdings, LL - Sole Member - 325 Interlocken Parkway B; Broomfield, CO 80021-8043

Have any of the above been convicted of gambling, tax evasion, any felony, or been denied a liquor license?

None

Corporate Purpose _____

Corporate Recording Number (s) _____

Registered Agent _____

	Trade Name of Device/ Serial Number	Manufacturer	Description	Game Rating Code Color
1.	CR Toy RBC 30 161905	Rainbow Crane	30" Toy Crane	
2.				
3.				
4.				
5.				
6.				
7.				

(Additional information can be added using attached sheet)

Total Fees: \$ 100.00

Has a liquor license been issued or applied for? If so, when?

This application is for the machines as listed above. Any changes in the status of those machines will necessitate a new application.

 Owner/Agent for Owner

SUBSCRIBED AND SWORN TO
 Before me this 1st
 Day of June 2016

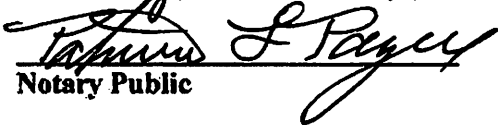
 Notary Public

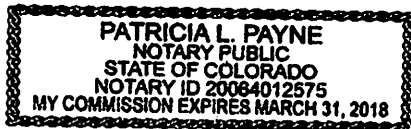

Jewel #3192
17930 South Wolf Rd

Store

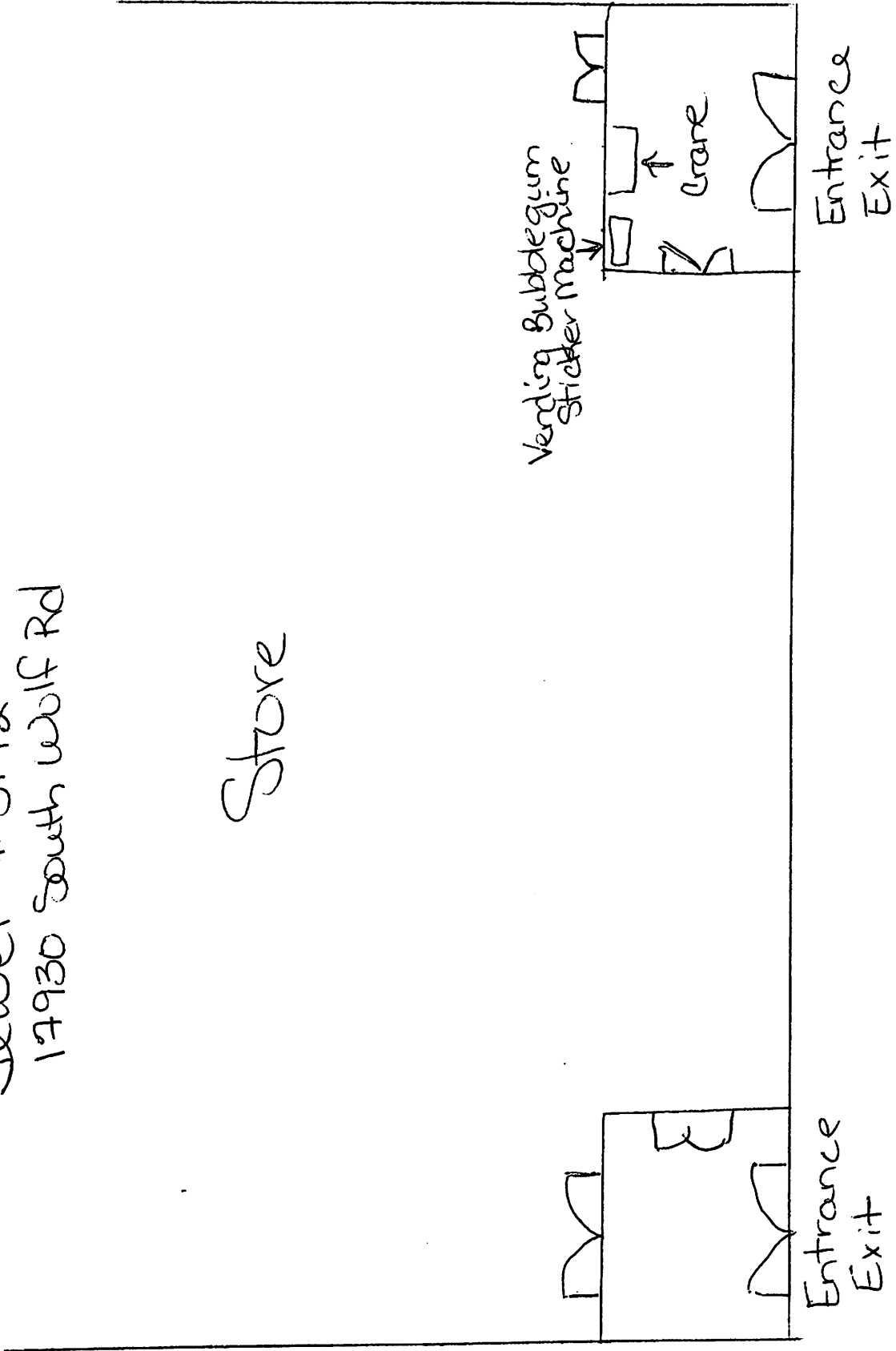

Toys R Us



VILLAGE OF ORLAND PARK
Development Services Department
14700 S. Ravinia Avenue
Orland Park, IL 60462

Phone - (708) 403-5300 Fax (708) 403-6215
www.orland-park.il.us

Amusement Device Operator's License

1. Submit fully completed application. Make sure that the games are each listed along with description and serial number. Include rating as per attached AAMA Game Ratings. AAMA Game Ratings will be verified at the following website:
<http://www.coin-op.org/Games%20Rating%20List.htm>
2. Have application notarized.
3. Include check for application fee. Fee is \$50.00 per machine, minimum being \$100.00. (Covers 2 machines)
4. Submit drawing showing location of machines and distance to surrounding objects. Show doorways in room.
5. Application needs to be approved by the Village Board of Trustees. It is highly recommended that someone from your business establishment be present at the Board Meeting to answer questions.

Please read the enclosed copies of the Amusement Device Ordinances, Title 7, Chapter 5 of the Orland Park Village Code. Pay particular notice to ALL restrictions. Sign below to indicate receipt of said code and to acknowledge that you have read it in it's entirety.

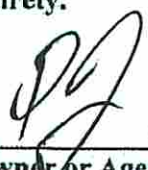

Owner or Agent for Owner



Date

VILLAGE OF ORLAND PARK

14700 RAVINIA AVENUE

ORLAND PARK, IL 60462

Phone: (708) 403-5300 Fax (708) 403-6215

APPLICATION FOR AUTOMATIC AMUSEMENT DEVICE OPERATORS LICENSE

Please Note:

Any misrepresentation or falsification of the information sought below may result in revocation of the license as granted. You must be 21 years of age or older and be a U. S. Citizen to apply. Any license issued as a result of this application shall terminate next December 31st.

Name of Business National Entertainment Network LLC Business Phone (303) 444-2559

Business Address 325 Interlocken Pkwy B; Broomfield, CO 80021

Names and Addresses of Principal Owners

Edward R Flaherty - CEO/President - 325 Interlocken Parkway B; Broomfield, CO 80021-8043

Peter Jacobson - CFO - 325 Interlocken Parkway B; Broomfield, CO 80021-8043

Address of premises where amusement devices are to be operated (if different from business address).

Toy's R Us #6023 - 45 Orland Square Dr

Type of Business Coin-Operated Amusement Devices

Corporation/Association/Partnership

Names and Addresses of Principal Officers or of all Shareholders over 5%.

NEN MCP Holdings, LL - Sole Member - 325 Interlocken Parkway B; Broomfield, CO 80021-8043

Have any of the above been convicted of gambling, tax evasion, any felony, or been denied a liquor license?

None

Corporate Purpose _____

Corporate Recording Number (s) _____

Registered Agent _____

	Trade Name of Device/ Serial Number	Manufacturer	Description	Game Rating Code Color
1.	CR Toy RBC 60 122769	Rainbow Crane	60" Toy Crane	
2.	Kiddie Ride Prem 12365	Kiddie Ride	Spider Ride	
3.				
4.				
5.				
6.				
7.				

(Additional information can be added using attached sheet)

Total Fees: \$ 100.00

Has a liquor license been issued or applied for? If so, when?

This application is for the machines as listed above. Any changes in the status of those machines will necessitate a new application.

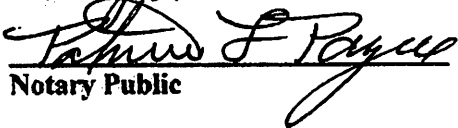

 Owner/Agent for Owner

SUBSCRIBED AND SWORN TO
 Before me this 1st
 Day of June 2016

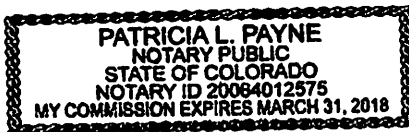
 Notary Public

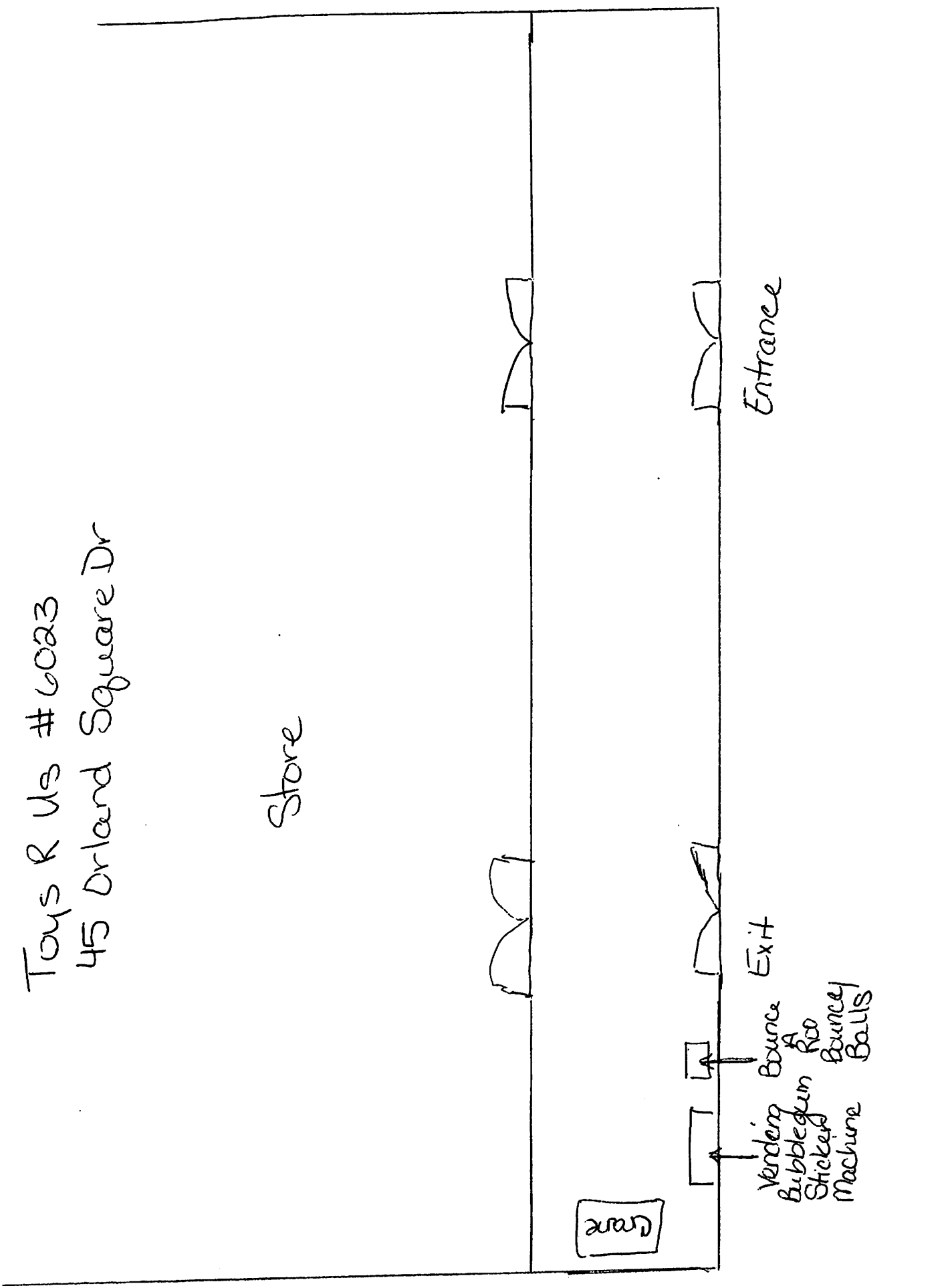

Toys R Us #6023
45 Orland Square Dr

Store





VILLAGE OF ORLAND PARK
Development Services Department
14700 S. Ravinia Avenue
Orland Park, IL 60462

Phone - (708) 403-5300 Fax (708) 403-6215
www.orland-park.il.us

Amusement Device Operator's License

1. Submit fully completed application. Make sure that the games are each listed along with description and serial number. Include rating as per attached AAMA Game Ratings. AAMA Game Ratings will be verified at the following website:
<http://www.coin-op.org/Games%20Rating%20List.htm>
2. Have application notarized.
3. Include check for application fee. Fee is \$50.00 per machine, minimum being \$100.00. (Covers 2 machines)
4. Submit drawing showing location of machines and distance to surrounding objects. Show doorways in room.
5. Application needs to be approved by the Village Board of Trustees. It is highly recommended that someone from your business establishment be present at the Board Meeting to answer questions.

Please read the enclosed copies of the Amusement Device Ordinances, Title 7, Chapter 5 of the Orland Park Village Code. Pay particular notice to ALL restrictions. Sign below to indicate receipt of said code and to acknowledge that you have read it in it's entirety.

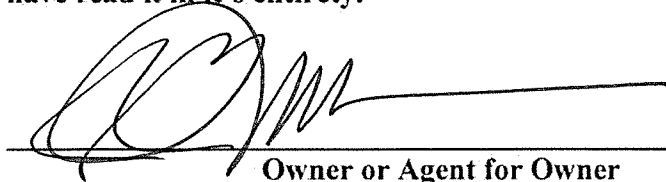

Owner or Agent for Owner

June 15, 2016

Date

VILLAGE OF ORLAND PARK

14700 RAVINIA AVENUE

ORLAND PARK, IL 60462

Phone (708) 403-5300 Fax (708) 403-6215

APPLICATION FOR AUTOMATIC AMUSEMENT DEVICE OPERATORS LICENSE

Please Note:

Any misrepresentation or falsification of the information sought below may result in revocation of the license as granted. You must be 21 years of age or older and be a U. S Citizen to apply. Any license issued as a result of this application shall terminate next December 31st.

Name of Business Twin Peaks Orland Park, LLC d/b/a Twin Peaks Restaurant Business Phone (708) 590-6293

Business Address 5151 Beltline Road, Suite 1200, Dallas, TX 75254

Names and Addresses of Principal Owners

Twin Restaurant Investment Company II, LLC (Sole Member); 5151 Beltline Road, Suite 1200, Dallas, TX 75254

John B. Gessner, Manager, 5151 Beltline Road, Suite 1200, Dallas, TX 75254

Scott E. Gordon, Manager, 5151 Beltline Road, Suite 1200, Dallas, TX 75254

Address of premises where amusement devices are to be operated (if different from business address).

16154 South La Grange Road, Orland Park, IL 60467

Type of Business Full Service Restaurant

Corporation/Association/Partnership

Names and Addresses of Principal Officers or of all Shareholders over 5%.

Twin Restaurant Investment Company II, LLC (Sole Member), 5151 Beltline Road, Suite 1200, Dallas, TX 75254 - 100%

Have any of the above been convicted of gambling, tax evasion, any felony, or been denied a liquor license?

No

Corporate Purpose Operation of full service restaurant

Corporate Recording Number (s) 05258189

Registered Agent CT Corporation, 208 S. LaSalle, Chicago, IL 60604

	Trade Name of Device/ Serial Number	Manufacturer	Description	Game Rating Code Color
1.	Golden Tee Live #14-144391	Incredible Technologies	Golden Tee Live 2016 Pedestal	Green-Suitable for All Ages
2.				
3.				
4.				
5.				
6.				
7.				

(Additional information can be added using attached sheet)

Total Fees: \$ 100.00

Has a liquor license been issued or applied for? If so, when?

Village of Orland Park License #16-300 issued May 2, 2016; State of Illinois License #1A-1130046 issued May 16, 2016

This application is for the machines as listed above. Any changes in the status of those machines will necessitate a new application.

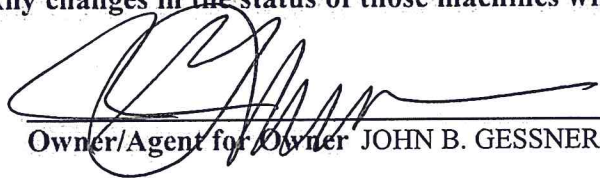
 Owner/Agent for Owner JOHN B. GESSNER

SUBSCRIBED AND SWORN TO
 Before me this 15th
 Day of June 2016

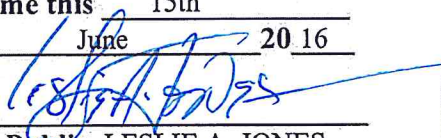
 Notary Public LESLIE A. JONES
 IN AND FOR THE STATE OF TEXAS

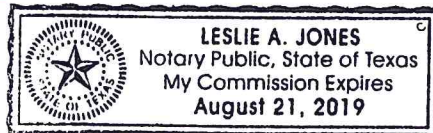

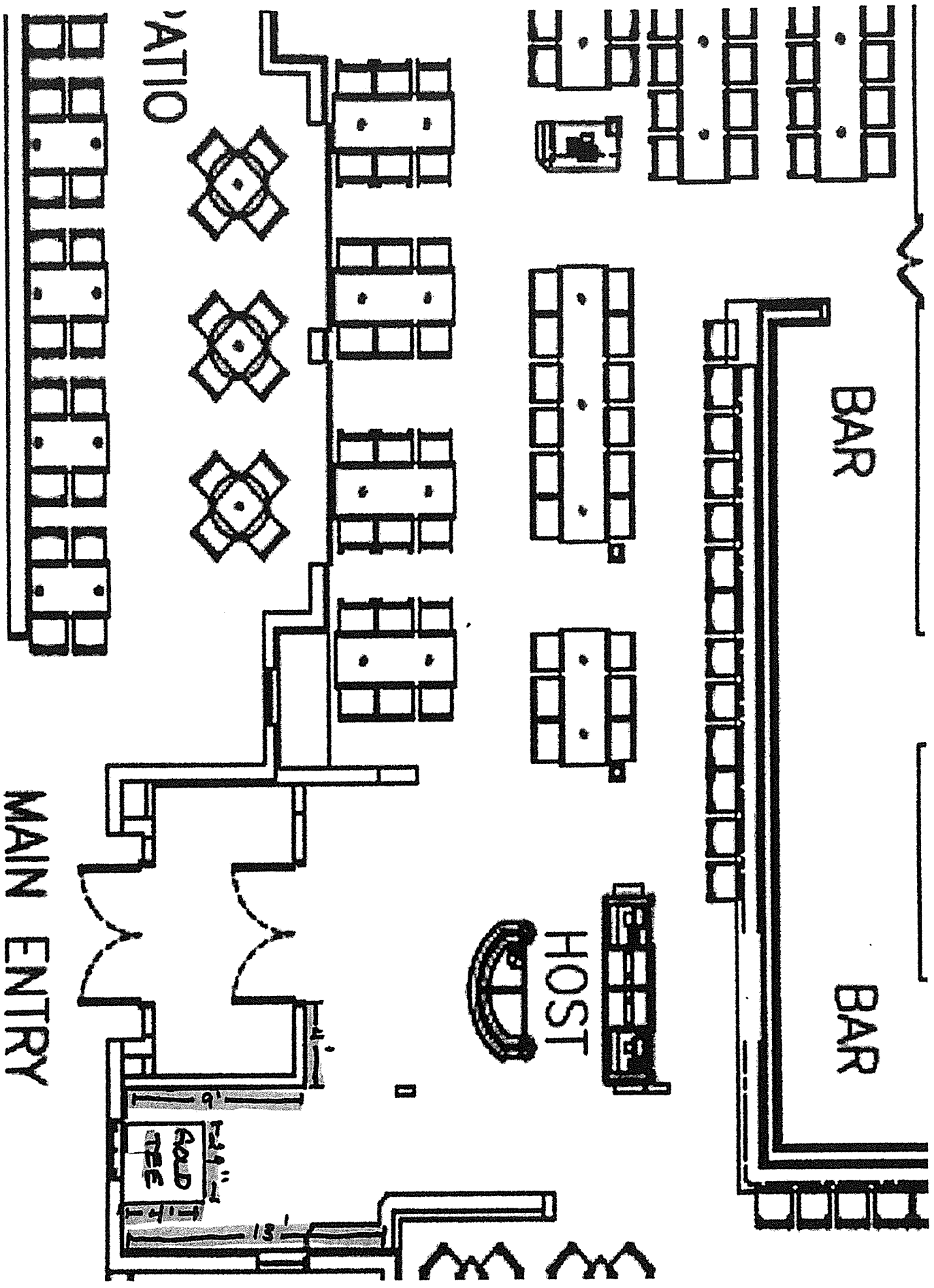

BAR

BAR

PATIO

HOST

MAIN ENTRY

GOLD TREE

13'

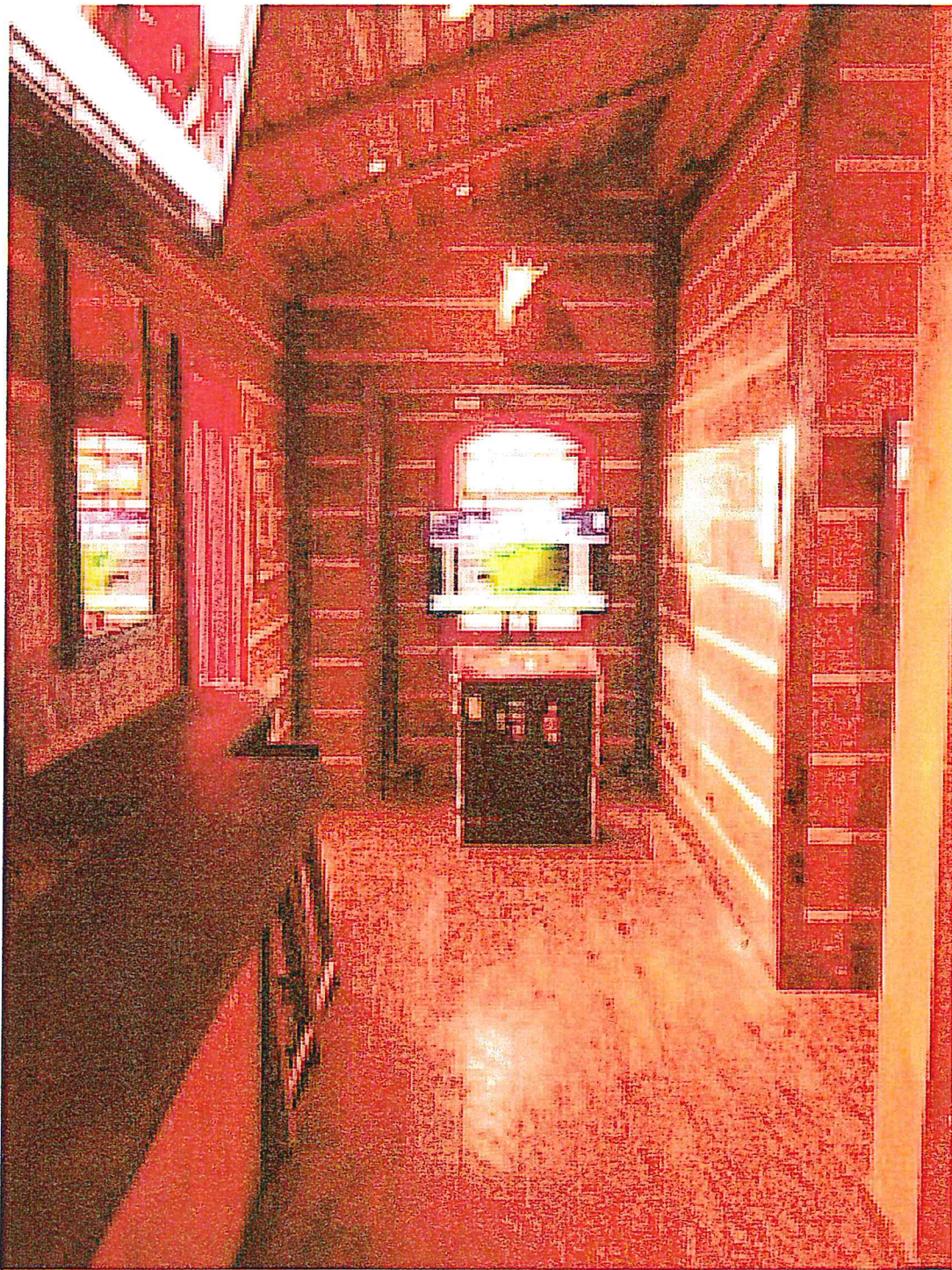



VILLAGE OF ORLAND PARK
Development Services Department
14700 S. Ravinia Avenue
Orland Park, IL 60462

Phone - (708) 403-5300 Fax (708) 403-6215
www.orland-park.il.us

Amusement Device Operator's License

1. Submit fully completed application. Make sure that the games are each listed along with description and serial number. Include rating as per attached AAMA Game Ratings. AAMA Game Ratings will be verified at the following website:
<http://www.coin-op.org/Games%20Rating%20List.htm>
2. Have application notarized.
3. Include check for application fee. Fee is \$50.00 per machine, minimum being \$100.00. (Covers 2 machines)
4. Submit drawing showing location of machines and distance to surrounding objects. Show doorways in room.
5. Application needs to be approved by the Village Board of Trustees. It is highly recommended that someone from your business establishment be present at the Board Meeting to answer questions.

Please read the enclosed copies of the Amusement Device Ordinances, Title 7, Chapter 5 of the Orland Park Village Code. Pay particular notice to ALL restrictions. Sign below to indicate receipt of said code and to acknowledge that you have read it in it's entirety.

[Signature]

Owner or Agent for Owner

6/15/16

Date

VILLAGE OF ORLAND PARK

14700 RAVINIA AVENUE

ORLAND PARK, IL 60462

Phone (708) 403-5300 Fax (708) 403-6215

APPLICATION FOR AUTOMATIC AMUSEMENT DEVICE OPERATORS LICENSE

Please Note:

Any misrepresentation or falsification of the information sought below may result in revocation of the license as granted. You must be 21 years of age or older and be a U. S Citizen to apply. Any license issued as a result of this application shall terminate next December 31st.

Name of Business Fatties Pub Business Phone (708) 645-4901

Business Address 14420 John Humphrey Ave Orland Park

Names and Addresses of Principal Owners

Steve LaRocco
7633 Lakeside Dr
Frankfort, IL 60423

Address of premises where amusement devices are to be operated (if different from business address).

Type of Business Pub

Corporation/Association/Partnership

Names and Addresses of Principal Officers or of all Shareholders over 5%.

Steve LaRocco
7633 Lakeside Dr
Frankfort, IL 60423

Have any of the above been convicted of gambling, tax evasion, any felony, or been denied a liquor license?

No

Corporate Purpose _____

Corporate Recording Number (s) _____

Registered Agent _____

\\Ftovhserver\devserv\CKrygowski\AMUSEDEV\AmusementDeviceApplication.DOC

D6847-789-1 016-123
CORPORATE PPT: B-CAT TNC

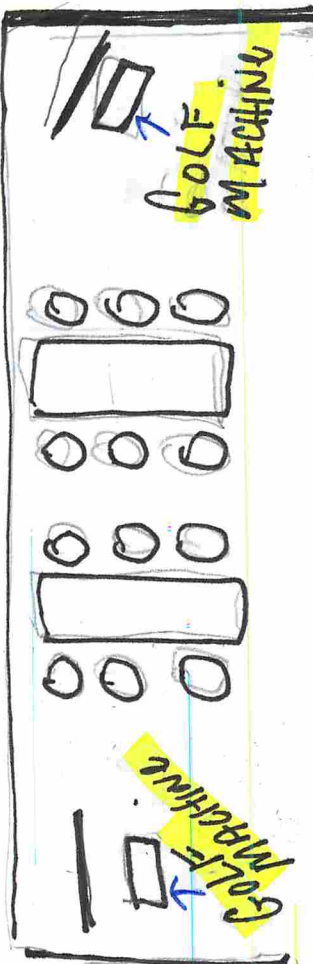
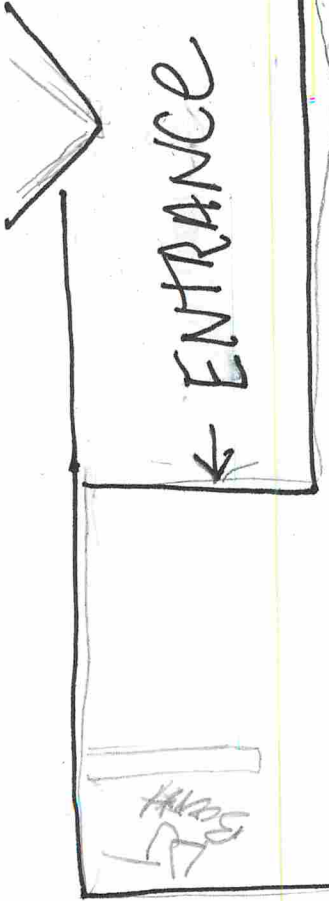

Beer
GARDEN →

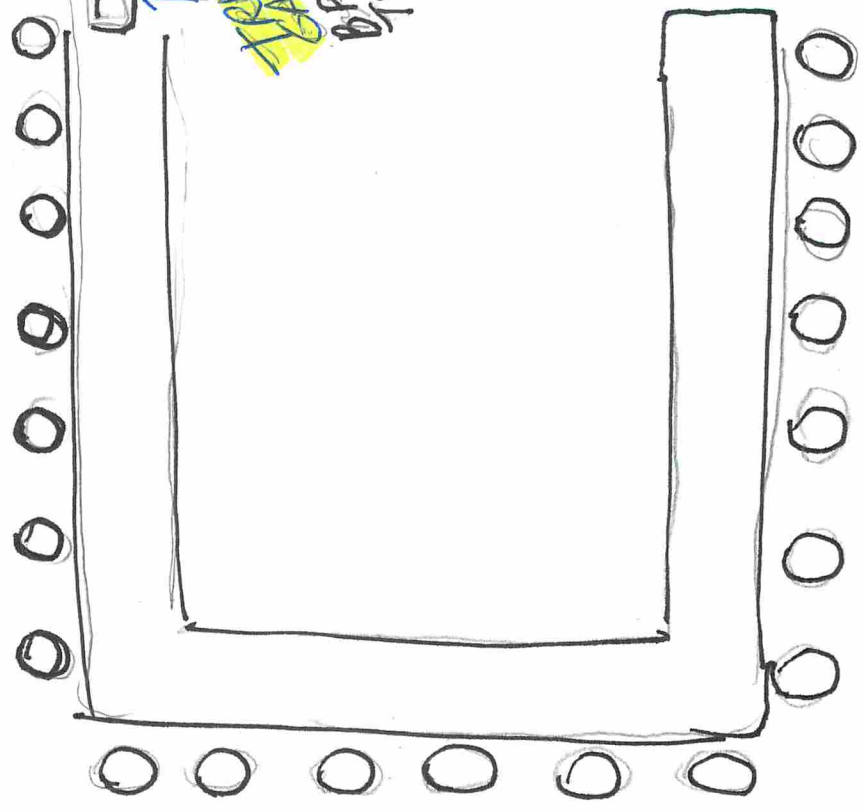
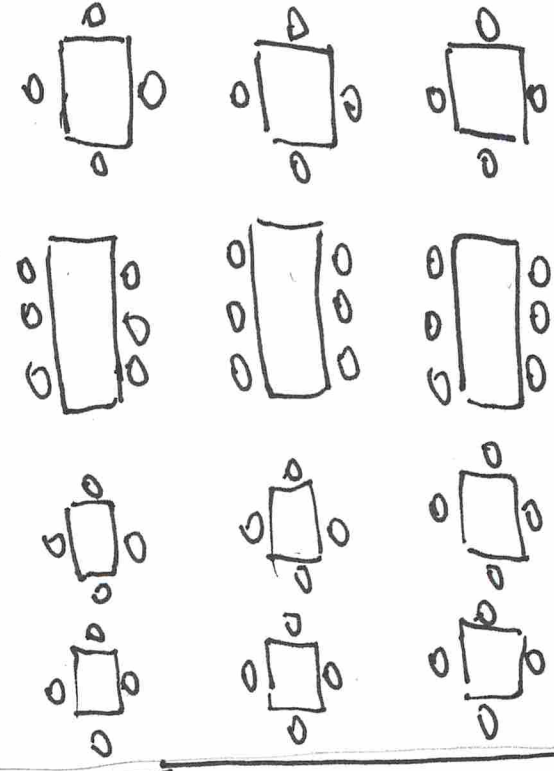

PARL
BOARD

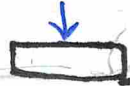

→ BATHROOMS
HALL

Subway

Kitchen



VILLAGE OF ORLAND PARK
Development Services Department
14700 S. Ravinia Avenue
Orland Park, IL 60462

Phone - (708) 403-5300 Fax (708) 403-6215
www.orland-park.il.us

Amusement Device Operator's License

1. Submit fully completed application. Make sure that the games are each listed along with description and serial number. Include rating as per attached AAMA Game Ratings. AAMA Game Ratings will be verified at the following website:
<http://www.coin-op.org/Games%20Rating%20List.htm>
2. Have application notarized.
3. Include check for application fee. Fee is \$50.00 per machine, minimum being \$100.00. (Covers 2 machines)
4. Submit drawing showing location of machines and distance to surrounding objects. Show doorways in room.
5. Application needs to be approved by the Village Board of Trustees. It is highly recommended that someone from your business establishment be present at the Board Meeting to answer questions.

Please read the enclosed copies of the Amusement Device Ordinances, Title 7, Chapter 5 of the Orland Park Village Code. Pay particular notice to ALL restrictions. Sign below to indicate receipt of said code and to acknowledge that you have read it in it's entirety.

J.P.T.
Justin Tauber

Owner or Agent for Owner

6-15-16

06-15-16

Date

VILLAGE OF ORLAND PARK

14700 RAVINIA AVENUE

ORLAND PARK, IL 60462

Phone (708) 403-5300 Fax (708) 403-6215

APPLICATION FOR AUTOMATIC AMUSEMENT DEVICE OPERATORS LICENSE

Please Note:

Any misrepresentation or falsification of the information sought below may result in revocation of the license as granted. You must be 21 years of age or older and be a U. S Citizen to apply. Any license issued as a result of this application shall terminate next December 31st.

Name of Business Gizmos Fun Factory Business Phone (773) 415-2988

Business Address 66 Orland Sq. Dr. Suite D, Orland Park, IL 60462

Names and Addresses of Principal Owners

Justin Tauber - 1517 Park West Circle, Munster, IN 46321
Kyle Ropac - 1021 Foy Ct., Crown Point, IN 46307

Address of premises where amusement devices are to be operated (if different from business address).

Type of Business Family Entertainment Center

Corporation/Association/Partnership

Names and Addresses of Principal Officers or of all Shareholders over 5%
Joseph Lalich - 12308 Northcote Ct, Saint John, IN 46373

Justin Tauber - 1517 Park West Circle, Munster, IN 46321

Kyle Ropac - 1021 Foy Ct., Crown Point, IN 46307

VU NGUYEN - 1501 South Lake George Dr., Mishawaka, IN 46545

Michael Lalich - 1501 South Lake George Dr., Mishawaka, IN 46545

Tony Ropac - 8353 Doubletree Drive North, Crown Point, IN 46307

Have any of the above been convicted of gambling, tax evasion, any felony, or been denied a liquor license?

Corporate Purpose Family Entertainment Center → Orland Park FEC LLC

Corporate Recording Number (s) 81-0849923

Registered Agent Douglas B. Wexler 55 W. Wacker Dr., F19

Chicago, IL 60601-1794

	Trade Name of Device/ Serial Number	Manufacturer	Description	Game Rating Code Color
1.				
2.				
3.				
4.				
5.				
6.				
7.				

(Additional information can be added using attached sheet)

Total Fees: \$ _____

Has a liquor license been issued or applied for? If so, when?

NO - Within two weeks

This application is for the machines as listed above. Any changes in the status of those machines will necessitate a new application.

J.R.T.
Owner/Agent for Owner

SUBSCRIBED AND SWORN TO

Before me this 16th
Day of June 2016

[Signature]
Notary Public



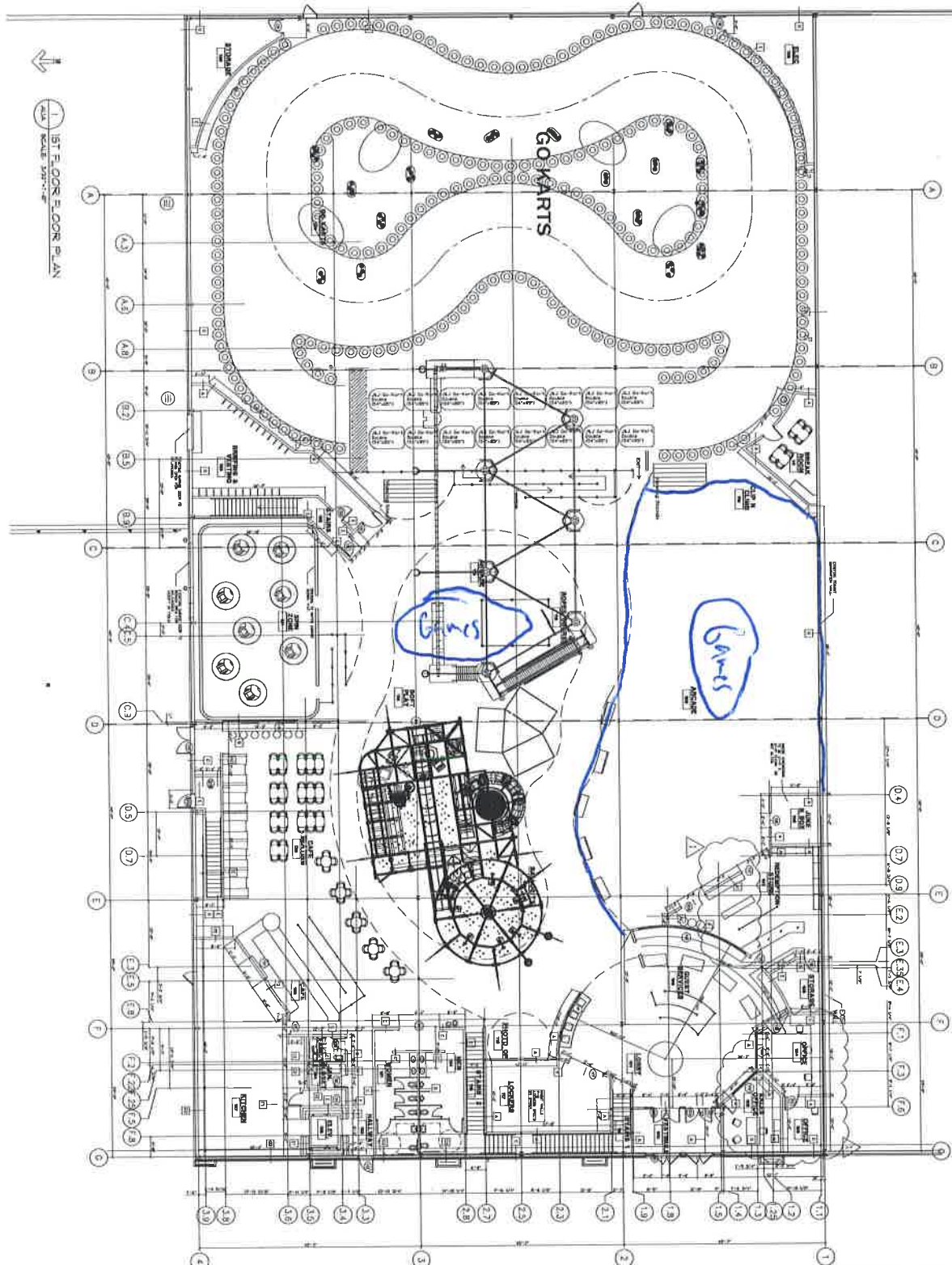

1ST FLOOR FLOOR PLAN
SCALE: 1/8" = 1'-0"

GENERAL NOTES

1. EXIST. INTERIOR COLUMNS IN OPEN
2. PAINT GENERAL AREA, UNIFORM
3. PAINT IN PANEL, ACENT PAINT
4. PAINT IN PANEL, ACENT PAINT
5. PAINT IN PANEL, ACENT PAINT
6. LOCATIONS TO BE RELOCATED BY OWNER

FLOOR PLAN LEGEND

- DOOR
- WALL
- UNIFORM
- ELEVATION TAG
- BALANCED PLAN TAG
- UNIFORM TAG
- DOOR TAG
- WALL TAG
- REFER TO TAG FOR WALL DETAILS
- MENTION CLASS
- DYNAMIC CAPTION BY STUDIO 418 BY
- PAINTING WALLS - PANELS ON
- ACCENT COLUMNS - PANELS ON
- GENERAL PAINTING - LATERAL
- REFER TO TAG

Legend

- Lobby
- Elevator
- Wall
- Door
- Window
- Stair
- Restroom
- Office
- Conference
- Storage
- Mechanical
- Electrical
- Plumbing
- Fire
- Security
- Signage
- Furniture
- Other

Dynamic Designs, P.C.
781 East Park & West Park
Orlando, FL 32819
Tel: 407-221-1966
Fax: 407-221-1967
www.dynamicdesigns.com

ORLAND PARK FEC
66 ORLAND PARK
ORLAND PARK, IL 60462

FIRST FLOOR PLAN
W/ DIMENSIONS

Sheet No. A11

MANUFACTURER	GAME DESCRIPTION	Game Rating	# of Swipers
Adrenaline Amusements	Crossy Road	Green	2
Adrenaline Amusements	Flying Tickets	Green	2
Adrenaline Amusements	Fruit Ninja - 2 TFX 1 Screen	Green	1
Andamiro	Spongebob Pineapple Arcade	Green	2
Bay tek	Big Bass Wheel	Green	3
Bay tek	Dizzy Chicken	Green	1
Bay tek	Full Tilt	Green	1
Bay tek	Grand Piano Keys	Green	2
Bay tek	Sink It Shootout (2Games+Sign)	Green	2
Benchmark	Chaos	Green	1
Benchmark	Monster Drop Xtreme	Green	2
Bob's Space Racers	Gear It Up w/Player Seat	Green	1
Coastal Amusements	Black Hole	Green	1
Coastal Amusements	Simpson Soccer	Green	1
Elaut	Tower of Tickets	Green	4
Elaut	Wizard of Oz 6 Player	Green	6
Innovative Concepts	Angry Birds	Green	1
Innovative Concepts	Down The Clown	Green	2
Innovative Concepts	Gold Fishin'	Green	1
Innovative Concepts	Ice Ball FX	Green	3
Innovative Concepts	Kung Fu Panda (Dojo Mojo Dlx)	Green	1
Innovative Concepts	Milk Jug Toss	Green	1
Innovative Concepts	NBA Hoops	Green	4
Innovative Concepts	Treasure Quest	Green	1
Innovative Concepts	Whack N Win 11.2	Green	1
Jennison	Ocean Pearls	Green	1
Namco	Goal Line Rush	Green	1
Namco	Jumpin Jackpot	Green	1
Skeeball	Giant Spin N Win - 6' w/Led	Green	1
Skeeball	Hot Shot Basketball (Giant)	Green	1
Team Play	Fish Bowl Frenzy	Green	1
Universal Space	Pirates Hook 4 Plyr	Green	4
Dynamo/Valley	Fire Storm 8' A/H w/O/H sound & rope lighting	Green	1
Kalkomat	Boxer Glove (Plain Color, Coin Mech no DBA)	Green	1
Namco	Alpine Racer	Green	1
Namco	Star Wars - Flat Screen Edition	Green	1
Raw Thrills	Aliens Armageddon 55" DX	Yellow	1
Raw Thrills	Batman 42" DX	Green	1
Raw Thrills	Buck Offline HD Wild Panorama	Yellow	1
Raw Thrills	Jurassic Park Environmental	Yellow	1
Raw Thrills	Moto GP	Green	2
Raw Thrills	Super Cars 42" Dlx	Green	2
Triotech	Typhoon Sitdown	Green	1
Apple	Photo Studio Deluxe	Green	1
Elaut	Big One Extreme	Green	1
Elaut	E Claw 900 1 Pl Crane	Green	4
Elaut	Plucky Ducky	Green	1
LAI	Color Match	Green	1

MANUFACTURER	GAME DESCRIPTION	Game Rating	# of Swipers
SEGA	Prize Locker skill merchandiser	Green	2
Smart	Candy House	Green	1
Bay tek	Big Bass Jackpot Marquee	N/A	0
Innovative Concepts	Down The Clown Marquee	N/A	0
Innovative Concepts	Ice Ball FX Marquee	N/A	0
Innovative Concepts	NBA Hoops LED Kit	N/A	0
Innovative Concepts	NBA Hoops Link Kit (Each Unit !!!)	N/A	0
Innovative Concepts	NBA Hoops Progressive Sign	N/A	0
Raw Thrills	BB Wild 3yr + Zombie + DD Kit	Yellow	0
Raw Thrills	BBHD 80" Monitor Stand	N/A	0
Triotech	Typhoon 10 Ride Update	Green	0

REQUEST FOR ACTION REPORT

File Number:	2016-0495
Orig. Department:	Public Works Department
File Name:	Orlan Brook Drive Culvert Replacement - Bid and Construction Engineering Services

BACKGROUND:

Orlan Brook Drive was originally constructed in the early 1970's. The culvert section of the construction involved the installation of two 72-inch corrugated metal culvert pipes that connected the two ponds south of Wheeler Drive. Over the past 40 years, these pipes have deteriorated considerably. There is significant deflection through the barrels of the pipes and the roadway pavement structure above the pipes has developed sink holes requiring significant patching over the past few years. The culvert pipes need to be replaced in order to maintain a structurally sound roadway.

On July 20, 2015, the Village Board approved a proposal from Baxter & Woodman to perform Phase I and Phase II Consulting Engineering Services for the Orlan Brook Drive Culvert Replacement Project. In order to facilitate the construction of the project, staff requested and received a proposal for Phase III Construction Services from Baxter & Woodman. Also responsible for providing oversight for the efficient implementation of the 2016 Road Improvement Program, Baxter & Woodman has established themselves as a proficient and professional consultant to the Village. Therefore, staff recommends approving the proposal from Baxter & Woodman for Phase II Construction Services for the Orlan Brook Drive Culvert Replacement Project in an amount not to exceed \$32,712 (proposal attached), plus a \$5,000 contingency for a total of \$37,712.00.

An Invitation to Bid for the culvert replacement work was advertised in the Southtown Star Newspaper on May 31, 2016. Sealed bids were opened by the Village Clerk's office on June 17, 2016 (summary attached). Eight (8) sealed bids were received. Bids were submitted by Airy's Inc. of Tinley Park, Illinois; D. Construction of Coal City, Illinois; Hasse Construction Company, Inc. of Calumet City, Illinois; Kovilic Construction Company, Inc. of Franklin Park, Illinois; Northwest General Contractors, Inc. of Glen Ellyn, Illinois; Misfits Construction Company of Chicago, Illinois; Trine Construction Corporation of West Chicago, Illinois; and V3 Construction Group, LTD of Woodridge, Illinois.

Hasse Construction Company, Inc. of Calumet City, Illinois, was identified as the lowest responsible bidder for the Orlan Brook Culvert Replacement project with a submitted project cost of \$260,000.00. This cost is below staff's estimate of \$300,000 for the anticipated improvements; therefore, it is staff's recommendation that Hasse Construction Company, Inc. of Calumet City, Illinois be awarded the Orlan Brook Culvert Replacement project in the amount of \$260,000.00, plus a \$10,000 contingency for a total of \$270,000.

This agenda item is being considered by the Public Works Committee and the Village Board of Trustees on the same night.

BUDGET IMPACT:

Funds to complete this project are included in the FY2016 Water and Sewer budget, account 031-6007-470500.

REQUESTED ACTION:

I move to approve award of the Orlan Brook Culvert Replacement Project bid to Hasse Construction Company, Inc. of Calumet City, Illinois for an amount not to exceed \$270,000;

And

Approve awarding Phase III Construction Engineering Services for the Orlan Brook Drive Culvert Replacement Project to Baxter & Woodman, Inc. of Mokena, Illinois, in an amount not to exceed \$37,712.

June 22, 2016

Mr. John J. Ingram
Infrastructure Maintenance Director
Village of Orland Park
14700 S. Ravinia Avenue
Orland Park, Illinois 60462

Subject: Village of Orland Park – Orland Brook Drive Culvert Replacement-Construction Services

Dear Mr. Ingram:

Baxter & Woodman, Inc. is pleased to submit this proposal to provide Construction Services for the Subject Project. All terms and conditions of the Master Agreement dated March 17, 2015 with the Village of Orland Park shall apply.

PROJECT SUMMARY

Improvements consist of removal of existing culvert pipes, installation of dual reinforced concrete pipes, curb and sidewalk replacement, water main relocation, HMA patching, and parkway restoration

PROJECT SCHEDULE

Our services are anticipated to start on July 18, 2016 and record drawings completed by November 11, 2016.

The construction work is anticipated to start in early/mid-August, 2016 and the final completion date is October 21, 2016.

Our scope of services, tasks, anticipated hours of work, and fee are provided below.

CONSTRUCTION SCOPE OF SERVICES

1. Act as the Village's representative with duties, responsibilities and limitations of authority as assigned in the construction contract documents.
2. PROJECT INITIATION: (9hrs)
 - Attend and prepare minutes for the preconstruction conference, and review the Contractor's proposed construction schedule and list of subcontractors.
3. CONSTRUCTION ADMINISTRATION- (40 hrs.)
 - Attend bi-weekly construction progress meetings as needed.

- Shop drawing and submittal review by Engineer shall apply only to the items in the submissions and only for the purpose of assessing, if upon installation or incorporation in the Project, they are generally consistent with the construction documents. Village agrees that the contractor is solely responsible for the submissions (regardless of the format in which provided, i.e. hard copy or electronic transmission) and for compliance with the contract documents. Village further agrees that the Engineer's review and action in relation to these submissions shall not constitute the provision of means, methods, techniques, sequencing or procedures of construction or extend to safety programs or precautions. Engineer's consideration of a component does not constitute acceptance of the assembled item.
 - Provide Design Engineering service that are project related (as needed) including utility coordination before the construction work is started.
 - Prepare construction contract change orders and work directives when authorized by the Village.
 - Review the Contractor's requests for payments as construction work progresses, and advise the Village of amounts due and payable to the Contractor in accordance with the terms of the construction contract documents.
 - Research and prepare written response by Engineer to request for information from the Village and Contractor.
 - Project manager or other office staff visit site as needed.
 - Coordinate the services of a materials testing company to perform proportioning and testing of the Portland cement concrete and bituminous mixtures in accordance with the IDOT's Bureau of Materials manuals of instructions for proportioning. Review laboratory, shop and mill test reports of materials and equipment furnished by the Contractor. Services of a material testing company shall be furnished by the Village as deemed necessary by the Engineer.
4. FIELD OBSERVATION and DOCUMENTATION- (261 hrs)
- Engineer's site observation shall be at the times agreed upon with the Village. Engineer will provide a Resident Project Representative on a full-time basis of forty (40) hours per week for 4 weeks and a part-time basis of (5) hours a week for 10 weeks from Monday through Friday, not including legal holidays, (for up to 261 hours), as deemed necessary by the Engineer, to assist the Contractor with interpretation of the Drawings and Specifications, to observe in general if the Contractor's work is in conformity with the Final Design Documents, and to monitor the Contractor's progress as related to the Construction

Contract date of completion. Through standard, reasonable means, Engineer will become generally familiar with observable completed work. If Engineer observes completed work that is inconsistent with the construction documents, that information shall be communicated to the contractor and Village to address. Engineer shall not supervise, direct, control, or have charge or authority over any contractor's work, nor shall the Engineer have authority over or be responsible for the means, methods, techniques, sequences, or procedures of construction selected or used by any contractor, or the safety precautions and programs incident thereto, for security or safety at the site, nor for any failure of any contractor to comply with laws and regulations applicable to such contractor's furnishing and performing of its work. Engineer neither guarantees the performance of any contractor nor assumes responsibility for any contractor's failure to furnish and perform the work in accordance with the contract documents, which contractor is solely responsible for its errors, omissions, and failure to carry out the work. Engineer shall not be responsible for the acts of omissions of any contractor, subcontractor, or supplier, or of any of their agents or employees or any other person, (except Engineer's own agents, employees, and consultants) at the site or otherwise furnishing or performing any work; or for any decision made regarding the contract documents, or any application, interpretation, or clarification, of the contract documents, other than those made by the Engineer.

- Keep a daily record of the Contractor's work on those days that the Engineers are at the construction site including notations on the nature and cost of any extra work, and provide weekly reports to the Village of the construction progress and working days charged against the Contractor's time for completion.

5. PROJECT CLOSEOUT (28 hrs)

- Provide construction-related engineering services including, but not limited to, General Construction Administration and Resident Project Representative Services.
- Review construction record drawings for completeness prior to submission to CADD for further processing.
- Provide the Village a set of Auto-Cad construction record drawings in a pdf format on a USB Flash drive.

ENGINEERING FEE

Our engineering fee for the above stated scope of services will be based on our hourly billing rates for actual work time performed plus reimbursement of out-of-pocket expenses, including mileage direct costs which in **total will not exceed \$32,712.**

We appreciate the opportunity to work with the Village of Orland Park on this important project and we are available to begin work immediately upon your notice to proceed. If you find this proposal acceptable, please sign one copy and return for our files.

Please do not hesitate to call me 815-444-3335 if you have any questions or need additional information.

Sincerely,

BAXTER & WOODMAN, INC.
CONSULTING ENGINEERS



Derek J. Wold, P. E.
Vice President

Attachment

C: Mark L. Dachsteiner, P.E., Construction Manager

VILLAGE OF ORLAND PARK, IL

AUTHORIZED BY: _____

TITLE: _____

DATE: _____

I:\Crystal Lake\ORLPK\150623-Orlan Brook Culvert\Contract\60-Construction\For Contracts\150623.60 Proposal.doc

**Village of Orland Park, Illinois
Orlan Brook Drive Culvert Replacement
Section No.: N/A**

**CONSTRUCTION ENGINEERING
COST ESTIMATE OF CONSULTANT'S SERVICES IN DOLLARS**

Route: Orlan Brook Drive
Local Agency: Village of Orland Park

Section: N/A
Project: N/A
Job No.: N/A

*Firm's approved rates on file with IDOT's Bureau of Accounting and Auditing:	
Overhead Rate	<u>N/A</u>
Complexity Factor	<u>0</u>
Work Days M-F	<u>7/18/16-11/11/16 83</u>
Anticipated Service from 07/18/16 to 11/11/16	
Weeks of Service	16.5 Wks
Saturdays	2

Method of Compensation:

Cost Plus Fixed Fee 1 14.5%[DL + R(DL) + OH(DL) + IHDC]

Cost Plus Fixed Fee 2 14.5%[DL + R(DL) + 1.4(DL) + IHDC]

Cost Plus Fixed Fee 3 14.5%[(2.8 + R)DL] + IHDC

Direct Labor Multiple

Specific Rate X

Lump Sum

Element of Work	Employee Classification	Man-Hours	Payroll Rate	Payroll Costs	Overhead*	In-House Direct Costs	Services by Others	Profit	Total
PROJECT INITIATION	PRINCIPAL-Wold	0	\$180.00	\$0.00					\$0.00
	SR. ENGR. IV Dachsteiner	5	\$160.00	\$800.00		\$48.60			\$848.60
	ENGR. TECH III-Mijares	2	\$110.00	\$220.00		\$21.60			\$241.60
	CLERICAL II-Tobin	2	\$90.00	\$180.00					\$180.00
CONSTRUCTION ADMINISTRATION AND DESIGNER ASSISTANCE/SHOP DRAWING	SR. ENGR. IV Dachsteiner	30	\$160.00	\$4,800.00		\$48.60			\$4,848.60
	SR. ENGR. III-James	8	\$150.00	\$1,200.00					\$1,200.00
	ENGR. TECH III-Mijares	0	\$110.00	\$0.00					\$0.00
	CLERICAL II-Tobin	2	\$90.00	\$180.00					\$180.00
FIELD DESIGN/CONSTRUCTION LAYOUT	SR. ENGR III-James	0	\$140.00	\$0.00					\$0.00
	ENGR. TECH III-Mijares	0	\$110.00	\$0.00					\$0.00
	SURVEY TECH- III-Sweeny	0	\$95.00	\$0.00					\$0.00
FIELD OBSERVATION/DOCUMENTATION	ENGR. TECH I-Lauterbach	246	\$80.00	\$19,680.00		\$777.60			\$20,457.60
	ENGR. TECH III-Mijares	15	\$110.00	\$1,650.00		\$108.00			\$1,758.00
COMPLETION OF PROJECT	SR. ENGR. IV Dachsteiner	4	\$160.00	\$640.00					\$640.00
	ENGR. TECH I-Lauterbach	8	\$80.00	\$640.00		\$38.00			\$678.00
	CAD/SURVEY TECH-Bette	16	\$105.00	\$1,680.00					\$1,680.00
MATERIAL TESTING							\$0.00		\$0.00
TOTALS		338		\$31,670.00	\$0.00	\$1,042.40	\$0.00	\$0.00	\$32,712.40

CONSTRUCTION SERVICES TOTAL - NOT TO EXCEED \$32,712.40

Summary of In-House Direct Costs:
VEHICLE EXPENSES: TRAVEL - 1930MI @ CURRENT IRS RATE (\$0.54 FOR ESTIMATING PURPOSES) \$1,042.40
PRODUCTION, ADMINISTRATION, POSTAGE: \$0.00

Summary of Services by Others:
MATERIAL TESTING: \$0.00

Village of Orland Park Bid Tabulation

Bid Number: 16-021
Bid Issued: Tuesday May 31, 2016
Bid Opening: Friday June 17, 2016



Project Title: Orland Brook Drive Culvert Replacement
Department: Public Works
Addendum No. 1 June 9, 2016

Bidder	<u>Grand Total Bid Price</u>	Contact Person & Location
Airy's Inc.	\$384,415.50	James Welling 7455 W. Duvan Drive Tinley Park, IL 60477 P: 708-429-0660/ F: 708-429-0795 Email: james.welling@airys.com
D Construction Inc	\$278,630.00	Everett Leasure 1488 S. Broadway Coal City, IL 60416 P: 815-634-2555/ F: 815-634-8748 Email: eleasure@dconstruction.net
Hassee Construction Company, Inc.	\$260,000.00	Brian Staresina 10 Lincoln Ave (PO Box 300) Calumet City, IL 60409 P: 708-862-2450/ F: 708-862-2455 Email: bstaresoma@hasseconstruction.com
Kovilic Construction Co., Inc	\$485,841.00	Danilo Kovilic 3721 N. Carnation St. Franklin Park, IL 60131 P: 847-671-4978/ F: 847-671-5329 Email: dkovilic@kovilic.com
Misfits Construction Company	\$467,724.00	John Thomas 233 South Wacker Drive, Suite 8400 Chicago, IL 60606 P: 312-420-5041/ F: 206-339-3613 Email: johnthomas@misfitsconstruction.com
Northwest General Contractors, Inc.	\$424,436.00	Omar Ali 799 E. Roosevelt Rd G-110 Glen Ellyn, IL 60137 P: 773-617-2391/ F: 630-665-3175 email: omar.ali@enwgc.net
Trine Construction Corp	\$388,520.00	Michael M. Rendina 27W364 North Avenue West Chicago, IL 60185 P: 630-668-4626/ F: 630-668-4828 Email: info@trineconstruction.com
V3 Construction Group, Ltd	\$360,000.00	Mike Famiglietti 7325 Janes Avenue Woodridge, IL 60517 P: 630-724-9200/ F: 630-724-9202 Email: mfamiglietti@v3co.com

Bids are subject to review for completeness, accuracy and compliance with all terms and conditions of the bid specifications.

Prepared by: Denise Domalewski, Contract Administrator - Village of Orland Park

BIDDER SUMMARY SHEET

Bid #16-021 – ORLAN BROOK DRIVE CULVERT REPLACEMENT
Project Name

Business Name: Hasse Construction Company, Inc.

Street Address: 10 Lincoln Ave. (PO Box 300)

City, State, Zip: Calumet City, IL 60409

Contact Name: Brian Staresina

Title: Project Manager

Phone: (708) 862-2450 Fax: (708) 862-2455

E-Mail address: bstaresina@hasseconstruction.com

PRICE PROPOSAL

GRAND TOTAL BID PRICE	\$ <u>260,000.00</u>
-----------------------	----------------------

AUTHORIZATION & SIGNATURE

Name of Authorized Signee: John B. Hasse

Signature of Authorized Signee: 

Title: Secretary Date: June 17, 2016

UNIT PRICE SHEET

**Bid #16-021
Orlan Brook Drive Culvert Replacement**

The undersigned, having become familiar with the Documents, Construction Plans, and Specifications as designated in Bid #16-021 hereby proposes to provide and furnish all of the labor, materials, necessary tools, expendable equipment and all utility and transportation services necessary to perform and complete in a workmanlike manner all of the work required for and the work described in the following schedule in connection with the construction of the Orlan Brook Drive Culvert Replacement.

No	Item	Quantity	Unit	Unit Price	Amount
1	EARTH EXCAVATION	16	CU YD	\$57.50	\$920.00
2	REMOVAL AND DISPOSAL OF UNSUITABLE MATERIAL	243	CU YD	\$36.00	\$8,748.00
3	TRENCH BACKFILL	135	CU YD	\$56.50	\$7,627.50
4	POROUS GRANULAR BACKFILL	243	CU YD	\$33.75	\$8,201.25
5	TOPSOIL FURNISH AND PLACE, 4"	148	SQ YD	\$6.75	\$999.00
6	NITROGEN FERTILIZER NUTRIENT	2	POUND	\$28.25	\$56.50
7	POTASSIUM FERTILIZER NUTRIENT	2	POUND	\$28.25	\$56.50
8	SEEDING, CLASS 4A	0.25	ACRE	\$8,190.00	\$2,047.50
9	EROSION CONTROL BLANKET	148	SQ YD	\$5.65	\$836.20
10	SODDING, SALT TOLERANT	130	SQ YD	\$7.90	\$1,027.00
11	SUPPLEMENTAL WATERING	1	UNIT	\$675.00	\$675.00
12	TEMPORARY EROSION CONTROL SEEDING	4	POUND	\$115.00	\$460.00
13	PERIMETER EROSION BARRIER	150	FOOT	\$3.50	\$525.00
14	INLET FILTERS	3	EACH	\$180.00	\$540.00
15	TEMPORARY EROSION CONTROL BLANKET	148	SQ YD	\$5.65	\$836.20
16	STONE RIPRAP, CLASS A3	36	SQ YD	\$105.00	\$3,780.00
17	WASHOUT BASIN	1	EACH	\$695.00	\$695.00
18	AGGREGATE BASE COURSE, TYPE B 4"	71	SQ YD	\$9.50	\$674.50
19	AGGREGATE BASE COURSE, TYPE B 9"	144	SQ YD	\$18.50	\$2,664.00
20	HOT-MIX ASPHALT BINDER COURSE, IL-19.0, N50	26	TON	\$169.00	\$4,394.00
21	HOT-MIX ASPHALT SURFACE COURSE, MIX "D", N50	13	TON	\$225.50	\$2,931.50
22	BITUMINOUS MATERIALS (TACK COAT)	98	POUND	\$5.50	\$539.00
23	PORTLAND CEMENT CONCRETE SIDEWALK 5 INCH	457	SQ FT	\$9.25	\$4,227.25
24	PAVEMENT REMOVAL	144	SQ YD	\$8.25	\$1,188.00
25	COMBINATION CURB AND GUTTER REMOVAL	110	FOOT	\$6.25	\$687.50
26	SIDEWALK REMOVAL	602	SQ FT	\$1.75	\$1,053.50
27	PIPE HANDRAIL	112	FOOT	\$182.50	\$20,440.00
28	CONCRETE END SECTION, STANDARD 542011, 72", 1:3	4	EACH	\$12,000.00	\$48,000.00
29	PIPE CULVERTS, CLASS A, TYPE 1 EQUIVALENT ROUND-SIZE 72"	118	FOOT	\$521.50	\$61,537.00
30	STORM SEWERS, CLASS A, TYPE 2 18"	20	FOOT	\$116.00	\$2,320.00
31	STORM SEWER REMOVAL 18"	29	FOOT	\$4.25	\$123.25
32	MANHOLES, TYPE A, 4'-DIAMETER, TYPE 1 FRAME, CLOSED LID	1	EACH	\$3,425.00	\$3,425.00
33	INLETS, TYPE A, TYPE 1 FRAME, OPEN LID	1	EACH	\$1,565.00	\$1,565.00
34	REMOVING INLETS	1	EACH	\$350.00	\$350.00
35	COMBINATION CONCRETE CURB AND GUTTER	120	FOOT	\$30.00	\$3,600.00
36	MOBILIZATION	1	LSUM	\$20,441.15	\$20,441.15
37	TRAFFIC CONTROL AND PROTECTION (SPECIAL)	1	LSUM	\$5,641.00	\$5,641.00
38	THERMOPLASTIC PAVEMENT MARKING - LINE 4"	100	FOOT	\$5.65	\$565.00
39	DUCTILE IRON WATER MAIN 12"	60	FOOT	\$242.50	\$14,550.00
40	CONNECTION TO EXISTING WATER MAIN, 10"	2	EACH	\$1,478.00	\$2,956.00
41	CONSTRUCTION LAYOUT	1	LSUM	\$4,981.00	\$4,981.00
42	TEMPORARY INFORMATION SIGNING	52	SQ FT	\$11.25	\$585.00
43	STEEL CASINGS, 24"	40	FOOT	\$115.65	\$4,626.00
44	GATE VALVE 12" WITH VAULT, 60"	1	EACH	\$4,820.00	\$4,820.00
45	TRIAXIAL GEOGRID REINFORCEMENT, TYPE II	566	SQ YD	\$5.45	\$3,084.70

Grand Total for Improvements = \$260,000.00

(Enter this amount as Total Proposal Price on Proposal Summary Sheet)

The foregoing total shall be the basis for establishing the amount of the labor and payment and performance bonds and is not to be construed as a lump sum Contract Price. The actual number of units used will determine the final cost of the project.

Bidder

Firm Name:

JOHN B HASSE

Signed:

[Signature]

Title:

PM.

Dated:

6/17/16

REQUEST FOR ACTION REPORT

File Number: **2016-0467**
 Orig. Department: **Village Manager**
 File Name: **Amend Village Policy - Resolution**

BACKGROUND:

The current Village policy regarding paid annual vacation to the Village Manager, Assistant Village Manager and Department Directors who have completed twenty (20) or more years of service to the Village is five (5) weeks.

In order to be competitive and to attract and keep certain long-term employees of the Village, it is being recommended to grant three (3) weeks of paid time off to the Village Manager, Assistant Village Manager and Department Directors who have completed twenty (20) or more years of service to the Village in the capacity of Village Manager, Assistant Village Manager or Department Director.

It is recommended that paid time off granted in accordance with this policy may not be accrued if not used by the employee during the current employment year or any subsequent employment year.

In addition, the current Village policy regarding paid annual vacation for certain full-time Village employees is hereby amended to provide that a Village Manager, Assistant Village Manager or Department Director who has completed twenty (20) or more years of service to the Village in such capacity may not hereafter accrue more than fifteen (15) days (i.e., 120 hours) of unused vacation days for each year of service after having completed twenty (20) or more years of service.

BUDGET IMPACT:

REQUESTED ACTION:

I move to pass Resolution Number _____, entitled: RESOLUTION ESTABLISHING A VILLAGE POLICY OF PAID TIME OFF FOR CERTAIN VILLAGE EMPLOYEES WHO HAVE COMPLETED TWENTY (20) OR MORE YEARS OF SERVICE AS VILLAGE MANAGER, ASSISTANT VILLAGE MANAGER OR DEPARTMENT DIRECTORS AND LIMITING ACCRUAL OF VACATION TIME FOR SUCH EMPLOYEES

..T

RESOLUTION ESTABLISHING A VILLAGE POLICY OF PAID TIME OFF FOR CERTAIN VILLAGE EMPLOYEES WHO HAVE COMPLETED TWENTY (20) OR MORE YEARS OF SERVICE AS VILLAGE MANAGER, ASSISTANT VILLAGE MANAGER OR DEPARTMENT DIRECTORS AND LIMITING ACCRUAL OF VACATION TIME FOR SUCH EMPLOYEES

..B

WHEREAS, to be competitive and to attract and keep certain long-term Village employees, it is deemed necessary and desirable to grant, in addition to vacation days, paid time off to the Village Manager, Assistant Village Manager and Department Directors who have completed twenty (20) or more years of service to the Village in the capacity of Village Manager, Assistant Village Manager or Department Director.

NOW, THEREFORE, BE IT RESOLVED by the Village President and Board of Trustees of the Village of Orland Park, Cook and Will Counties, Illinois, as follows:

SECTION 1:

Following adoption of this Resolution, a Village Manager, Assistant Village Manager or Department Director who has completed twenty (20) years of service in such capacity shall be granted, in addition to employment benefits already earned or provided, fifteen (15) days (i.e., 120 hours) of paid time off annually, calculated from the date he/she achieved twenty (20) years of service as Village Manager, Assistant Village Manager or Department Director.

SECTION 2:

Paid time off granted in accordance with Section 1 hereof may not be accrued if not used by the employee during the current employment year or any subsequent employment year.

SECTION 3:

The current Village policy regarding paid annual vacation for certain full-time Village employees is hereby amended to provide that a Village Manager, Assistant Village Manager or Department Director who has completed twenty (20) or more years of service to the Village in such capacity may not hereafter accrue more than fifteen (15) days (i.e., 120 hours) of unused vacation days for each year of service after having completed twenty (20) or more years of service.

SECTION 4:

All other provisions of the current Village policy of paid vacation or accrual of unused vacation days for certain full-time Village employees, not in conflict herewith, are hereby ratified and confirmed.

SECTION 5:

This Resolution shall be in full force and effect upon its adoption as provided by law.

REQUEST FOR ACTION REPORT

File Number:	2016-0502
Orig. Department:	Village Manager
File Name:	Refuse, Recycling and Yard Waste Collection and Disposal Agreement - First Amendment

BACKGROUND:

In 2013, the Village and Waste Management of Illinois entered into a Refuse Recycling and Yard Waste Collection and Disposal Contract. Per the current contract, multiple family residential customers are identified as: multiple family living units, including apartments, condominiums, and residential buildings comprised of between five (5) and fifty (50) units and pick-up service frequency is one time per week.

The Village was notified that the existing contract with Waste Management did not specify in detail the types of buildings under the residential category and the meaning of the terms "Commercial Multiple Family Customers" and "Multiple Family Residential Customers".

This amendment of the contract includes the new definition for multiple family residential buildings, which will be defined as a detached, stand-alone building(s), including apartments, condominiums and residential buildings, which contain between five (5) and fifty (50) units. Therefore, if a resident owns or resides in a unit within a single stand-alone building that has between five (5) and fifty (50) units in the same building, that residential unit would fall under the definition "Multiple Family Residential Building(s)" and will be billed by the Village of Orland Park as a residential account under the Village's waste hauling agreement.

Also, a "Commercial Multiple Family Building" is defined as a single, detached and stand-alone building that contains fifty-one (51) residential units or more. Residential units within a commercial multiple family building will not be covered under the terms of the Village's agreement with Waste Management. The new terms and definitions are effective as of June 1, 2016.

The first amendment to the agreement is attached for the Board's review and approval.

BUDGET IMPACT:

None

REQUESTED ACTION:

I move to approve authorizing the Village Manager to execute the First Amendment to the Refuse, Recycling and Yard Waste Collection and Disposal Agreement with Waste Management of Illinois.

**FIRST AMENDMENT TO THE REFUSE, RECYCLING AND YARD WASTE
COLLECTION AND DISPOSAL AGREEMENT**

1. The VILLAGE OF ORLAND PARK (“Orland Park”) and WASTE MANAGEMENT OF ILLINOIS, INC. (“Contractor”) (collectively the “Parties”) enter into this First Amendment to the Refuse, Recycling and Yard Waste Collection and Disposal Agreement (the “First Amendment”) on June 1, 2016, having previously entered into a Refuse Recycling and Yard Waste Collection and Disposal Agreement (the “Collection and Disposal Contract”) in June, 2013.

2. The purpose of this First Amendment is to amend the meaning of the terms “Commercial Multiple Family Customers” and “Multiple Family Residential Customers”.

3. The definition of “Commercial Multiple Family Customers” in Section 2 of the Collection and Disposal Contract shall be deleted and be replaced with the following terminology and definition:

“Commercial Multiple Family Building”, which shall be defined as a single, detached and stand-alone building that contains fifty-one (51) residential units or more. Services for residential units within a Commercial Multiple Family Building will not be covered under the terms of the Village’s waste hauling agreement.”

4. The definition of “Multiple Family Residential Customers” in Section 2 of the Collection and Disposal Contract shall be deleted and be replaced with the following terminology and definition:

“Multiple Family Residential Buildings”, which shall be defined as a building(s), including apartments, condominiums and residential buildings, that contains between five (5) and fifty (50) units.”

5. Based on the above amended definitions, as of June 1, 2016, the Parties agree that the proper interpretation under the Collection and Disposal Contract, for all Orland Park residential units, is that in order for a residential unit to fall within the definition of a Commercial Multiple Family Building and not be covered under the terms of the Collection and Disposal Contract, that resident would need to own or reside in a unit that is located in a detached and stand-alone building that has at least fifty-one (51) units in that same single building. An individual separate building that has fifty-one (51) units or more contained within that same, single building, is exempt from the Collection and Disposal Contract as it would be considered a commercial account. If a resident owns or resides in a unit within a single stand-alone building that has between five (5) and fifty (50) units in the same building, that residential unit would fall under the defined term “Multiple Family Residential Building(s)” and would be billed by the Village of Orland Park as a multifamily residential building under the Collection and Disposal Contract.

6. The Parties agree that the above stated definitions of the terms “Commercial Multiple Family Building” and “Multiple Family Residential Buildings” will apply effective as of June 1, 2016, in determining whether any individual Orland Park residential unit will be covered under the Collection and Disposal Contract.

7. The Village represents that as of June 1, 2016, there is only one building, called the 9750 Ninety Seven Fifty Condo building, within the Village of Orland Park that falls within the

definition of “Commercial Multiple Family Building” (i.e., single, detached building containing fifty-one residential units or more). The Village agrees that as of June 1, 2016, the Village must provide advance written notification to Contractor in the event any other building that falls within the definition of Commercial Multiple Family Building exists within the village of Orland Park.

8. Waste Management of Illinois, Inc. agrees to discontinue billing as commercial customers, any single building located in the Village of Orland Park that contains fifty (50) or less residential units and that is managed by the Old Orchard Condo Association and agrees, unless the building or those units receive services beyond those set forth in the Collection and Disposal Contract. As of June 1, 2016, the Village of Orland Park can bill these residential units within the Old Orchard Condo buildings directly since they are covered the Collection and Disposal Contract. Starting on June 1, 2016, the Parties will treat these residential units as being within a Multiple Family Residential Buildings and Waste Management of Illinois, Inc. will provide Multiple Family Refuse Collection services to these residential units under the Collection and Disposal Contract.

9. This First Amendment may be executed in counterparts, each of which shall constitute an original, but all together shall constitute one and the same Agreement.

10. In the event any term or provision of this First Amendment shall be held illegal, invalid, unenforceable or inoperative as a matter of law, the remaining terms and provisions of this First Amendment shall not be affected thereby, but each such term and provision shall be valid and shall remain in full force and effect.

11. In construing this First Amendment and/or determining the rights of the parties hereunder, no party shall be deemed to have drafted or created this First Amendment, or any portion thereof.

12. The executing representatives of the parties to this First Amendment represent and certify that they are fully authorized to enter into the terms and conditions of this First Amendment and to execute and legally bind that party to it.

The Parties hereby agree to the terms and conditions stated above and indicate their agreement by executing this First Amendment on the date written below.

VILLAGE OF ORLAND PARK

By: _____
Its: _____

Dated: _____

WASTE MANAGEMENT OF ILLINOIS, INC.

By: _____
Its: _____

Dated: _____