

CENTENNIAL PARK AQUATIC CENTER, Orland Park, IL



CENTENNIAL PARK AQUATIC CENTER, Orland Park, IL

waterplay
Solutions Corp.

COPYRIGHT 2014 WATERPLAY SOLUTIONS CORP.

© Waterplay Solutions Corp. 25/04/2014 4:25:10 PM CentennialParkAquaticCenter-Phase1_OrlandPark_1_Apr2514.dwg

NOTES:

1. MAIN AQUATIC PLAY PAD AREA INCLUDING OVERSPRAY ZONE DESIGNED BY OTHERS
2. TO AVOID POTENTIAL DAMAGE TO SURROUNDING SOFTSCAPE AND TO KEEP PEDESTRIAN TRAFFIC FROM GETTING WET, WATERPLAY RECOMMENDS A MINIMUM OVERSPRAY OF 8' (2.44 METRES). FOR AREAS WITH HIGH WINDS, A LARGER OVERSPRAY ZONE MAY BE REQUIRED.
3. GRADE SURROUNDING OUTSIDE PERIMETER LANDSCAPE TO PROVIDE ADDITIONAL DRAINAGE AWAY FROM OVERSPRAY PAD.
4. SLOPES (INCLUDING MAIN PAD AND OVERSPRAY AREA) TO PROVIDE POSITIVE DRAINAGE TO DRAINS. IF CODE REQUIRES THAT THERE BE A ZONE SLOPING AWAY FROM THE MAIN SPRAY AREA, WATERPLAY RECOMMENDS AN ADDITIONAL DRY ZONE TO MEET THAT REQUIREMENT.
5. SLAB GRADES SUBJECT TO ENGINEER APPROVAL (NOTE ADA MAX CROSS SLOPE GRADE IS 2%).

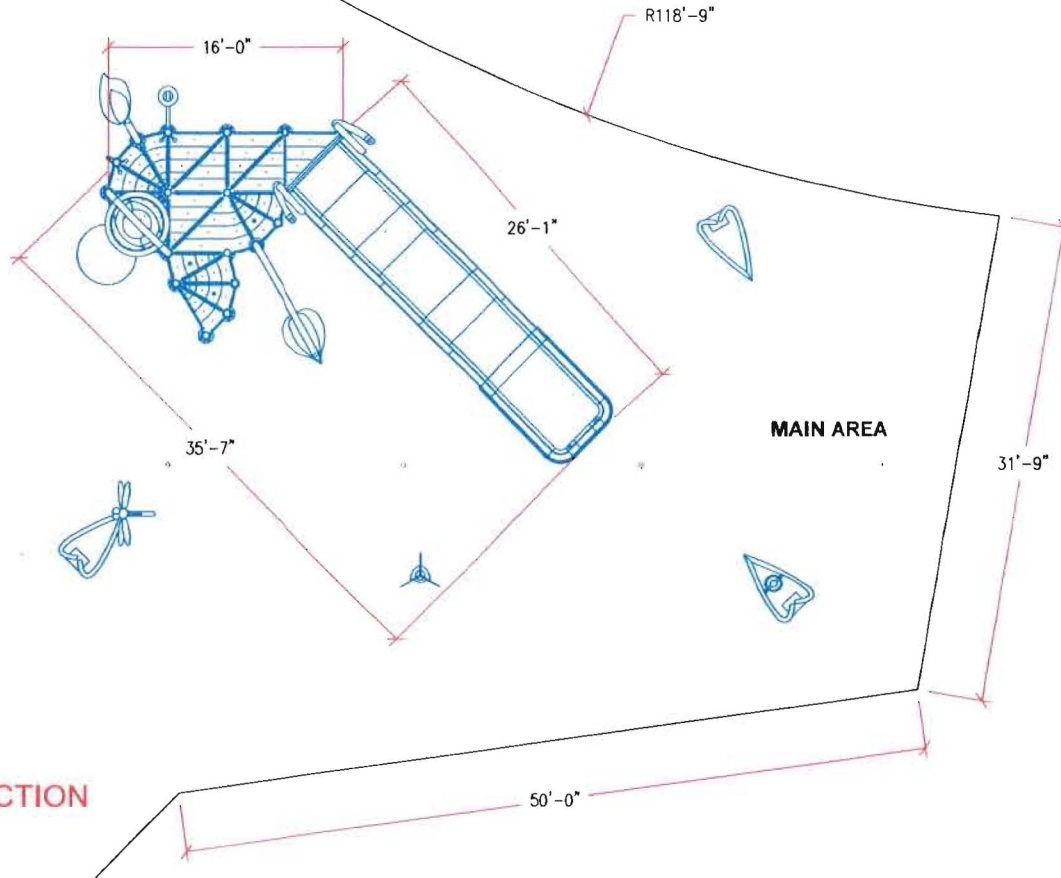

NOT FOR CONSTRUCTION PURPOSES

11 x 17 plot

FOR INFORMATION PURPOSES ONLY. LOCAL LANDSCAPE ARCHITECT, ENGINEER &/OR APPROPRIATE AUTHORITIES HAVING JURISDICTION MUST COMPLETE ALL PARK LAYOUT, MECHANICAL & ELECTRICAL DESIGN PRIOR TO CONSTRUCTION.

DESIGNED BY:
WATERPLAY SOLUTIONS CORP.

DWG NAME:
WATERPLAY PAD CONCEPT LAYOUT SHEET
3/3

SCALE: 1/8"=1'	DRAWN BY: MG	DATE: APR 25/14	REV #: 0
-------------------	-----------------	--------------------	-------------

FILE:
PROJECTS\2014\CENTENNIAL PARK

**CENTENNIAL PARK - PHASE 1 & 2
ORLAND PARK, IL**

REV	DESCRIPTION	REV'D BY	REV DATE



1451B ELLIS STREET, KELOWNA BC, CANADA V1Y 2A3
TEL. (250) 712-3393 FAX (250) 861-4814
EMAIL: info@waterplay.com

CUSTOM SL200.2 CLARKSVILLE

EST-07627-03

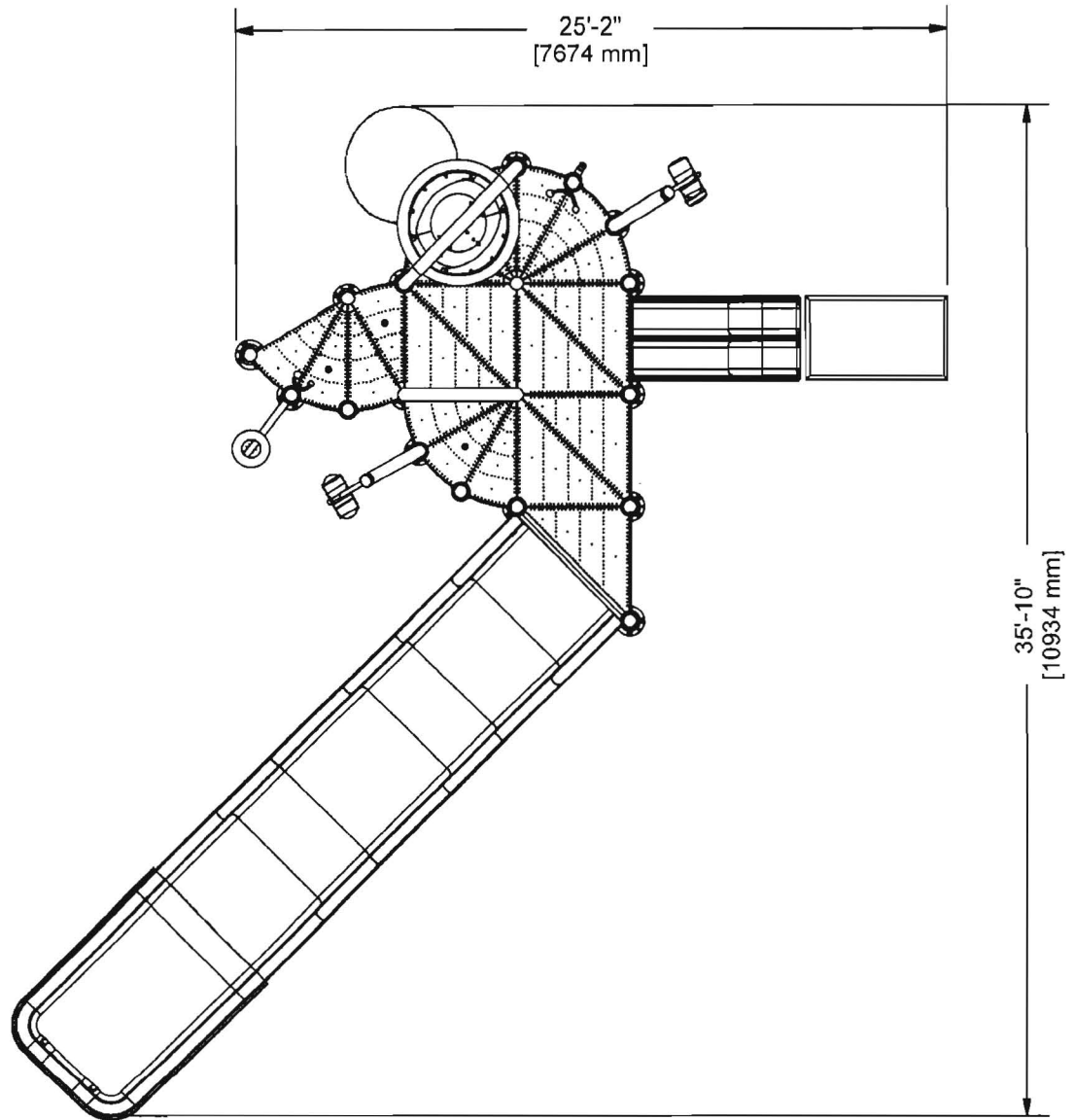

LEGEND

- A = SPRAY DIAMETER
- B = SPRAY LENGTH
- C = SPRAY WIDTH
- E = ELECTRICAL INLET
- F = ELECTRICAL OUTLET
- G = FINAL GRADE
- H = WATER INLET
- I = DRAIN OUTLET
- J = RECOMMENDED SPRAY HEIGHT

INITIALS _____

NOTE (IF APPLICABLE):
 -SPRAY AREA IS APPROXIMATE AND NOT TO SCALE
 -WATER SPRAY IS INDICATING NOZZLE LOCATION ONLY
 AND IS NOT AN INDICATION OF NOZZLE SPRAY PATTERN
 -FOOTING IS TO BE PROVIDED BY OTHERS

COMPONENT INCLUDES:
 -FOOTING TEMPLATE & ANCHOR HARDWARE
 -SERVICE TOOL(S)
 -TAMPER RESISTANT HARDWARE
 -WINTER BLANK NOZZLE(S) (IF APPLICABLE)
 -SPRAY NOZZLE(S) (IF APPLICABLE)

PAGE 3 OF 3

DRAWING:

REVISION: A



1451B Ellis Street
 Kelowna, BC, V1Y 2A3
 t: (250) 712-3393 f: (250) 861-4814
 e: design@waterplay.com w: waterplay.com

COPYRIGHT MATERIAL:
 ALL PLANS & DESIGNS AT ALL TIMES
 REMAIN THE PROPERTY OF WATERPLAY
 SOLUTIONS CORP. & CANNOT BE USED, OR
 REPRODUCED WITHOUT WRITTEN
 PERMISSION

NOTE: THIS IS A PARTIAL SPECIFICATION. FOR FULL PRODUCT
 SPECIFICATION, PLEASE REFER TO COMPONENT WRITTEN
 SPECIFICATION DOCUMENT. DUE TO OUR CONTINUING PRODUCT
 IMPROVEMENT PROGRAM, WATERPLAY SOLUTIONS CORP.
 RESERVES THE RIGHT TO CHANGE THIS SPECIFICATION WITHOUT
 NOTICE.

Customer Quotation

Quote Number: QUO-10718
 Customer: Imagine Nation, Inc (IL)
 Revision Number: 1

Drawing Name:

Ph. 1.250.712.3393
 Fx. 1.250.861.4814
 Tf. 1.800.590.5552
 web: www.waterplay.com
 email: sales@waterplay.com

Rep: Kirk Hutshinson

Waterplay Solutions Corp
1451 B. Ellis St.
Kelowna, BC V1Y 2A3 Canada

Quote Date: Thursday, May 01, 2014
 Expiry Date: Friday, August 01, 2014
 Status: In Progress

CUSTOMER INFORMATION

Customer : Imagine Nation, Inc (IL)	Bill To: Imagine Nation, Inc (IL)
Telephone : 1-800-324-6475	35 Feldland Street
Payment Terms : 50% deposit 50% to Ship	Bohemia NY USA
Currency : US Dollar	11716
Project Name : Centennial Park Aquatic Center, Phase I, Orland Park, IL	Ship To: Centennial Park
Type :	15600 West Ave
Shipping Terms : FCA - Origin Kelowna BC Ground	Orland Park IL USA
Requested Ship Date :	60462
Requested Delivery Date :	

Anchor Hardware Ship Date :
Anchor Hardware Ship Detail :

Description :

LINE ITEMS

<u>Part ID</u>	<u>Description</u>	<u>Price</u>	<u>Qty</u>	<u>Amount</u>
FREIGHTUS	S/H, Cargo to USA March 18, 2014 30-Day Estimate only - firm quote will be provided at time of order	\$6,425.00	1.00	\$6,425.00
EST-08302	Custom SL200 Centennial Park	\$135,850.00	1.00	\$135,850.00
0002-7440	DOUBLE DEX BASE UNIT	\$2,094.75	3.00	\$6,284.25
C02-DX19	Base, DEX, Single	\$570.00	1.00	\$570.00
Total:				\$149,129.25
Deposit:				\$74,564.63

* Plus applicable taxes *

WATERPLAY EQUIPMENT DOES NOT INCLUDE

Unless otherwise specified, Waterplay equipment DOES NOT include the following:

- Engineered drawings;
- Installation of equipment or other site amenities;
- Speciality fittings, flex couplers or other similar types of joining;
- Field piping/plumbing, double check valves, in-line strainer;
- Power supply, electrical conduit, wiring, connection fittings;
- Electronic solenoid valves (only included with the purchase of a Waterplay manifold).

COMPLIANCE WITH CODES AND STANDARDS

Quote Number: QUO-10718
Customer: Imagine Nation, Inc (IL)
Revision Number: 1

Waterplay Solutions Corp is an equipment manufacturer. We participate in ASTM panels for the aquatics industry and make every effort to ensure that our product will meet or exceed the ASTM standards. Waterplay also aims to ensure that our parks are ADA compliant and will be accessible to all children.

Waterplay products are purchased and installed all over the world; unfortunately it is not possible for Waterplay to know all local standards, codes and/or municipal by-laws that may apply to the equipment we provide. Waterplay will work with our customers to ensure compliance with applicable codes and standards but it is the customer's responsibility to identify those requirements prior to the signed purchase contract.

TERMS AND CONDITIONS

PURCHASE CONTRACT TERMS & CONDITIONS OF SALES:

Before signing the Purchase Contract, please read Waterplay Solutions Corp.'s (Waterplay) Terms and Conditions of Sale. The Customer's acceptance and understanding of these Terms and Conditions and all other supporting documentation provided as part of this package is evidenced by signing of this Purchase Contract.

PAYMENT TERMS AND FINANCIAL CONSIDERATIONS:

- Payment terms are 50% to begin production and 50% prior to shipment unless otherwise noted under Payment Terms at the top of the Purchase Contract. Full payment is due as per the stated terms. A holdback to a maximum of 5% may be considered for special circumstances and should be discussed prior to signing of the Purchase Contract and duly noted above. Any overdue balances are subject to interest charges of 2% per month.
- Taxes are not included on the Purchase Contract. Applicable taxes will be applied to all taxable goods and services based on the Canada Revenue Agency's GST/HST Place of Supply rules. Further information regarding place of supply can be obtained through the CRA's Technical Information Bulletin B-103.
- Should any changes be required to the products contained within the Purchase Contract after production begins on the order delays, modifications or reviews will be at the Customer's expense and will not affect the original Terms and Conditions of Sale.
- In the event that changes are made to the delivery schedule after the order is confirmed and the expected ship date and delivery date have been communicated, Waterplay reserves the right to request payment of the outstanding balance, based on the agreed to terms, starting from the confirmed ship date. Waterplay also reserves the right to charge a storage fee of \$250.00 (CAD) per week.
- Waterplay maintains a no return policy and asks all Customers to determine feature and colour selection carefully. Should an order be cancelled after production has commenced, Waterplay reserves the right to charge a 20% re-stocking fee.
- Cheque, Wire Transfer, Irrevocable Letter of Credit or Credit Card (note: an administrative fee of 3.5% may apply to payments made via Credit Card) are considered acceptable payment methods.

LEAD TIMES & LOGISTICS:

- Waterplay strives to complete orders within the customer's requested timeline. However, lead times are impacted by product mix and plant capacity at the time of order. Expected order completion and shipment from the Waterplay factory will be communicated at the time of order.
- Transit time from Waterplay's warehouse to the final shipping destination is in ADDITION to the above lead times. The above lead times assume that all necessary documentation and payments have been received.
- In order to facilitate the above production lead times, colour and graphic selection must be provided to Waterplay within 5 business days of signing of the Purchase Contract.
- Delivery of Waterplay product shall be either FCA Origin for all truck deliveries, or CIF Destination Port for all marine shipments. All products will be carefully wrapped and packaged to mitigate loss or damage during shipment and meet local regulations for import. All shipments must be inspected upon delivery and any damage, errors or omissions on parts must be reported to Waterplay and the transport company within 48 hours of receipt of goods.



Customer Quotation

Quote Number: QUO-10894
 Customer: Imagine Nation, Inc (IL)
 Revision Number: 0

Drawing Name:

Ph. 1.250.712.3393
 Fx. 1.250.861.4814
 Tf. 1.800.590.5552
 web: www.waterplay.com
 email: sales@waterplay.com

Rep: Kirk Hutchinson

Waterplay Solutions Corp
1451 B. Ellis St.
Kelowna, BC V1Y 2A3 Canada

Quote Date: Thursday, May 01, 2014
 Expiry Date: Friday, August 01, 2014
 Status: In Progress

CUSTOMER INFORMATION

Customer : Imagine Nation, Inc (IL) **Bill To:** Imagine Nation, Inc (IL)
Telephone : 1-800-324-6475 **35 Feldland Street**
Payment Terms : 50% deposit 50% to Ship **Bohemia NY USA**
Currency : US Dollar **11716**

Project Name : Centennial Park Aquatic Center, Phase II, Orland Park, IL **Ship To:** Centennial Park
Type : **15600 West Ave**
Shipping Terms : FCA - Origin Kelowna BC Ground **Orland Park IL USA**
Requested Ship Date : **60462**
Requested Delivery Date :

Anchor Hardware Ship Date :
Anchor Hardware Ship Detail :

Description :

LINE ITEMS

Part ID	Description	Price	Qty	Amount
FREIGHTUS	S/H, Cargo to USA March 18, 2014 30-Day Estimate only - firm quote will be provided at time of order	\$0.00	1.00	\$0.00
0002-4931	Blue Bottle, DEX DEX base not required on phased install Green stem, Green leaves and Blue flower only.	\$8,859.00	1.00	\$8,859.00
0002-6164	Dew Drop, DEX Double DEX base not required on phased install Light Green grass with Clear dumping bucket only.	\$6,902.00	1.00	\$6,902.00
0002-6166	Morning Grass 2, DEX Double DEX base not required for phased install Green only.	\$5,467.00	1.00	\$5,467.00
0002-6163	Sparx, DEX Double DEX Base not required on phased install Light Green grass with Blue body/tail and Green wings only.	\$9,001.00	1.00	\$9,001.00

Total: \$30,229.00

Deposit: \$15,114.50

*** Plus applicable taxes ***

WATERPLAY EQUIPMENT DOES NOT INCLUDE

Quote Number: QUO-10894
Customer: Imagine Nation, Inc (IL)
Revision Number: 0

Unless otherwise specified, Waterplay equipment DOES NOT include the following:

- Engineered drawings;
- Installation of equipment or other site amenities;
- Speciality fittings, flex couplers or other similar types of joining;
- Field piping/plumbing, double check valves, in-line strainer;
- Power supply, electrical conduit, wiring, connection fittings;
- Electronic solenoid valves (only included with the purchase of a Waterplay manifold).

COMPLIANCE WITH CODES AND STANDARDS

Waterplay Solutions Corp is an equipment manufacturer. We participate in ASTM panels for the aquatics industry and make every effort to ensure that our product will meet or exceed the ASTM standards. Waterplay also aims to ensure that our parks are ADA compliant and will be accessible to all children.

Waterplay products are purchased and installed all over the world; unfortunately it is not possible for Waterplay to know all local standards, codes and/or municipal by-laws that may apply to the equipment we provide. Waterplay will work with our customers to ensure compliance with applicable codes and standards but it is the customer's responsibility to identify those requirements prior to the signed purchase contract.

TERMS AND CONDITIONS

PURCHASE CONTRACT TERMS & CONDITIONS OF SALES:

Before signing the Purchase Contract, please read Waterplay Solutions Corp.'s (Waterplay) Terms and Conditions of Sale. The Customer's acceptance and understanding of these Terms and Conditions and all other supporting documentation provided as part of this package is evidenced by signing of this Purchase Contract.

PAYMENT TERMS AND FINANCIAL CONSIDERATIONS:

- Payment terms are 50% to begin production and 50% prior to shipment unless otherwise noted under Payment Terms at the top of the Purchase Contract. Full payment is due as per the stated terms. A holdback to a maximum of 5% may be considered for special circumstances and should be discussed prior to signing of the Purchase Contract and duly noted above. Any overdue balances are subject to interest charges of 2% per month.
- Taxes are not included on the Purchase Contract. Applicable taxes will be applied to all taxable goods and services based on the Canada Revenue Agency's GST/HST Place of Supply rules. Further information regarding place of supply can be obtained through the CRA's Technical Information Bulletin B-103.
- Should any changes be required to the products contained within the Purchase Contract after production begins on the order delays, modifications or reviews will be at the Customer's expense and will not affect the original Terms and Conditions of Sale.
- In the event that changes are made to the delivery schedule after the order is confirmed and the expected ship date and delivery date have been communicated, Waterplay reserves the right to request payment of the outstanding balance, based on the agreed to terms, starting from the confirmed ship date. Waterplay also reserves the right to charge a storage fee of \$250.00 (CAD) per week.
- Waterplay maintains a no return policy and asks all Customers to determine feature and colour selection carefully. Should an order be cancelled after production has commenced, Waterplay reserves the right to charge a 20% re-stocking fee.
- Cheque, Wire Transfer, Irrevocable Letter of Credit or Credit Card (note: an administrative fee of 3.5% may apply to payments made via Credit Card) are considered acceptable payment methods.

LEAD TIMES & LOGISTICS:

- Waterplay strives to complete orders within the customer's requested timeline. However, lead times are impacted by product mix and plant capacity at the time of order. Expected order completion and shipment from the Waterplay factory will be communicated at the time of order.
- Transit time from Waterplay's warehouse to the final shipping destination is in ADDITION to the above lead times. The above lead times assume that all necessary documentation and payments have been received.
- In order to facilitate the above production lead times, colour and graphic selection must be provided to Waterplay within 5 business days of signing of the Purchase Contract.
- Delivery of Waterplay product shall be either FCA Origin for all truck deliveries, or CIF Destination Port for all marine shipments. All products will be carefully wrapped and packaged to mitigate loss or damage during shipment and meet local regulations for import. All shipments must be inspected upon delivery and any damage, errors or omissions on parts must be reported to Waterplay and the transport company within 48 hours of receipt of goods.