



FRONTRUNNER SYSTEMS, INC.

6/6/2024

P R O P O S A L

SITE OF PROPOSED WORK:

PROPOSAL TO:

VILLAGE OF ORLAND PARK
15655 RAVINIA AVE

VILLAGE OF ORLAND PARK- WINDOWS
15655 RAVINIA AVE
ORLAND PARK, IL

ORLAND PARK, IL

DATE OF PLANS: SITE VISIT MAY 23RD

OFFICE: 708-403-6350

ARCHITECT:

N/A

CELL:

CONTACT: SCOTT HILAND

- (5) NEW CASEMENT WINDOWS @ APPROX 2'-4" X 8'-2" USING PEERLESS 5" DEPTH SYSTEM
> WE INCLUDE A 1/8" BARSTOCK GRID TO SIMULATE VERTICAL

- (2) WINDOWS @ APPROX 2'-7" X 4'-2" USING 3" OR 4" RAILS AND 3/4" SUB FRAME- HARDWARE INCLUDES ADAMSRITE PADDLE DEVICE AND STRIKE

NOTE: WE INCLUDE REMOVAL OF EXISTING (THROWN AWAY BY VILLAGES DUMPSTER)

INCLUDED: SHOP DRAWINGS, SUBMITTAL PACKAGE

EXCLUDED PERMITS AND BONDS, FINAL PROTECTION AND CLEANING

ABOVE WORK TO BE COMPLETED IN A WORKMAN LIKE MANNER FOR THE SUM OF:

SUM OF: \$69,312.00

TERMS - NET UPON COMPLETION OF WORK, WAIVERS WILL NOT BE FURNISHED UPFRONT

ANY ALTERATIONS OR DEVIATIONS FROM ABOVE SPECIFICATIONS INVOLVING EXTRA COSTS, WILL BE EXECUTED ONLY UPON WRITTEN ORDERS, AND WILL BECOME AN EXTRA CHARGE OVER AND ABOVE THE ESTIMATE. ALL AGREEMENTS CONTINGENT UPON STRIKES, ACCIDENTS OR OTHER DELAYS BEYOND OUR CONTROL. OWNER TO CARRY FIRE, TORNADO AND OTHER NECESSARY INSURANCE PERTAINING TO ABOVE WORKSITE. WORKMEN'S COMPENSATION AND PUBLIC LIABILITY INSURANCE ON ABOVE WORK TO BE TAKEN OUT BY: FRONTRUNNER SYSTEMS, INC.

NOTE: THIS PROPOSAL IS GOOD FOR 30 DAYS

**RESPECTFULLY SUBMITTED ON BEHALF OF
FRONTRUNNER SYSTEMS, INC.**

SIGNATURE OF ACCEPTANCE

LOUIS GUIDARELLI

INCLUDE TITLE/ DATE

Proposal amount is based upon Frontrunner Systems having unimpeded free access immediately adjacent to all openings. Minimum of 30% of the openings available for installation on any one mobilization of the installation team.

470 W. North Frontage Rd. Bolingbrook, IL 60440 PH 630-633-2700 FAX 630-633-2701

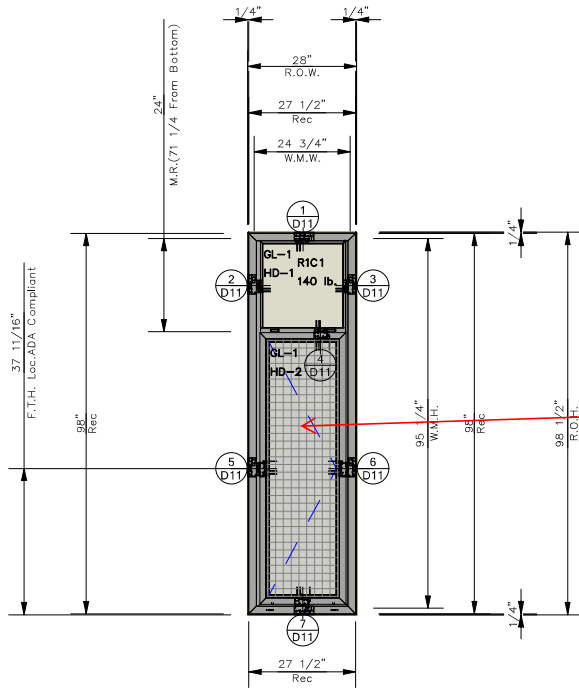

We can install 1/8" barstock to mimic a vertical

A G658
QTY. 5 THUS

Opening set to a 38 Inch ADA_FHA Code

		2403 South Main Phone No. (866) 425-0000 Fax No. (858) 254-3107	
ORLAND PARK VILLAGE HALL ADDRESS 1:		REVISION Base	
ADDRESS 2: 14700 S. Ravinia Ave		XXX	
GENERAL CONTRACTOR: Orland Park, IL		XXX	
SHEET E10	DATE: 06-05-24	SCALE: 1 / 32	CHNG BY: AUTO
OF 20	TIME: 14:29	DWG TITLE: ELEVATION	DWG. NO.: N/A

ELEVATION

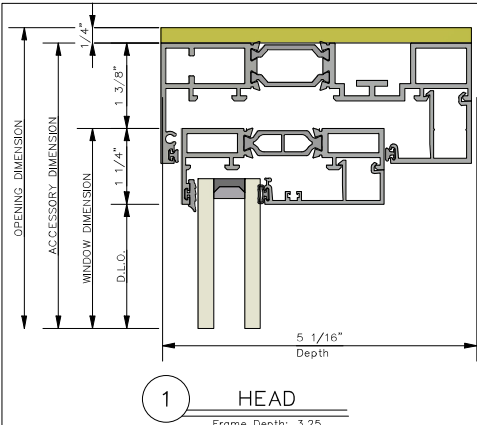

1 HEAD
Frame Depth: 3.25

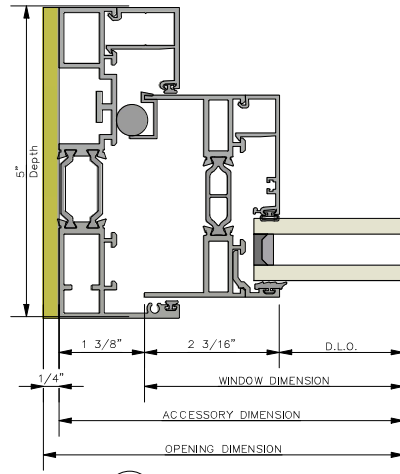

2 JAMB
Frame Depth: 3.25

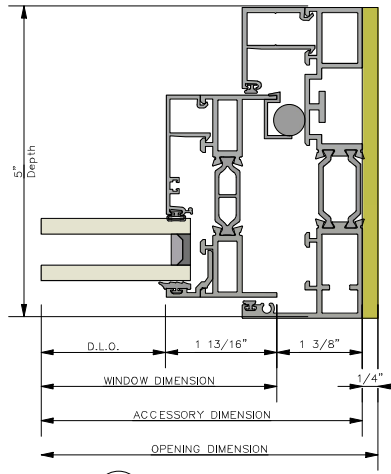

3 JAMB
Frame Depth: 3.25

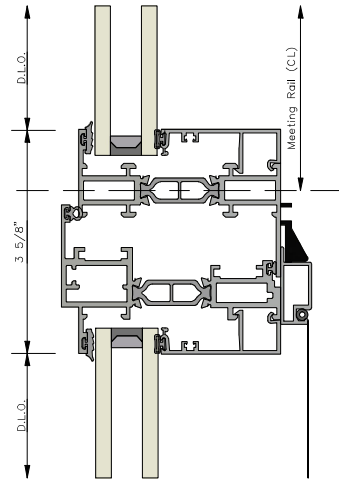

4 MEETING RAIL
Frame Depth: 3.25

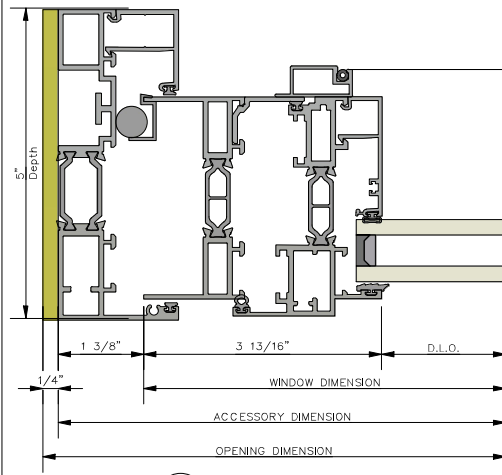

5 JAMB
Frame Depth: 3.25

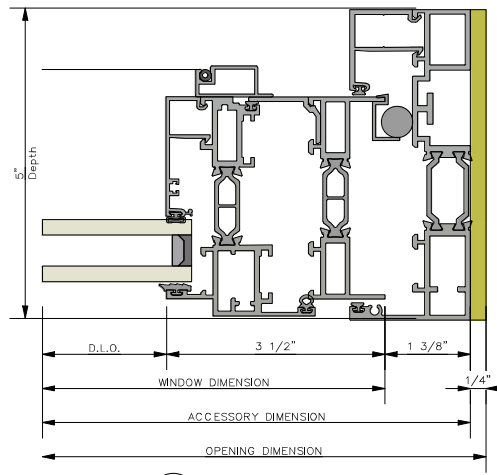

6 JAMB
Frame Depth: 3.25

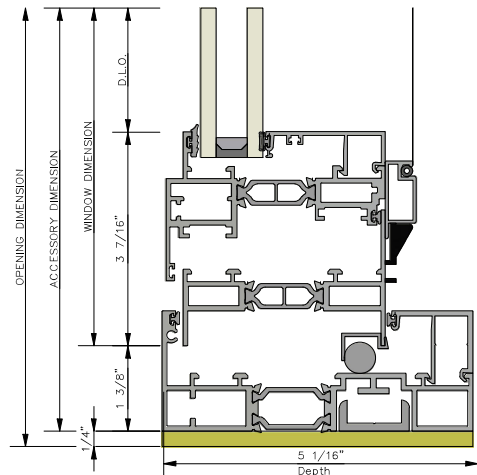

7 SILL
Frame Depth: 3.25

		2403 South Main Phone No. (866) 425-0000 Fax No. (858) 254-3107	
FOR NAME:	ORLAND PARK VILLAGE HALL	REVISION:	Base
ADDRESS 1:	14700 S. Ravinia Ave	XXX	XXX
ADDRESS 2:	Orland Park, IL	XXX	XXX
GENERAL CONTRACTOR:		XXX	XXX
SHEET:	D11	DATE:	06-05-24
OF:	20	TIME:	14:29
		DRAWN BY:	1 / 2
		SCALE:	AUTO
		DWG. TITLE:	DETAIL
		DWG. NO.:	N/A



Installation Instructions

These instructions are recommended installation instruction procedures.
Please refer to project specific shop drawings (if applicable).

2403 S Main St, Fort Scott, KS 66701
Toll Free: 800-279-9999 • Local: 620-223-4610
Fax: 620-224-3107 • peerlessproducts.com

2403 South Main Fort Scott, KS 66701 Phone No. (620) 425-0900 Fax No. (620) 224-3107		REVISION Base XXX XXX XXX
		CHKD BY: AUTO DWG. NO. N/A
DRAWN FOR:		DATE: 06-05-24 TIME: 14:29
FOR NAME: ORLAND PARK VILLAGE HALL		SCALE: N/A DWG TITLE: INSTALLATION
ADDRESS 1: 14700 S. Ravinia Ave		CHNG BY:
ADDRESS 2: Orland Park, IL		DWG. NO. N/A
GENERAL CONTRACTOR:		
SHEET 112	OF 20	

INSTALLATION