

LINTEL SCHEDULE			
MARK	MEMBER	SHAPE	REMARKS
L1	8x8 BOND BEAM W/2-#5		GROUT SOLID BOND BEAM. SEE DETAIL 4/S1.1

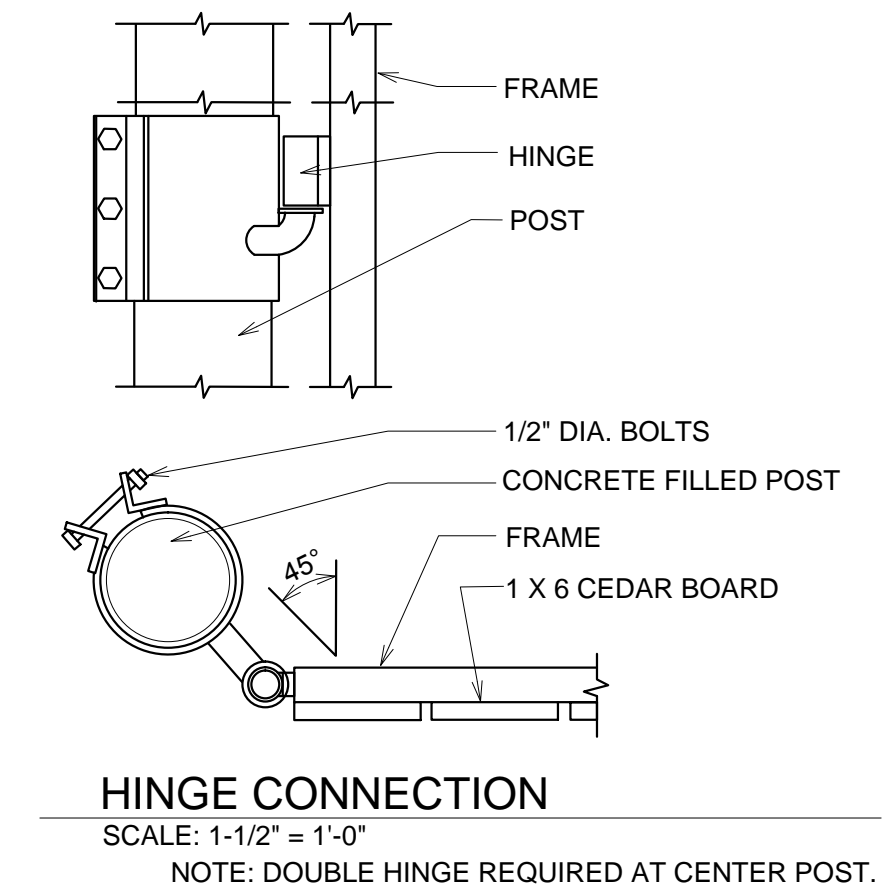
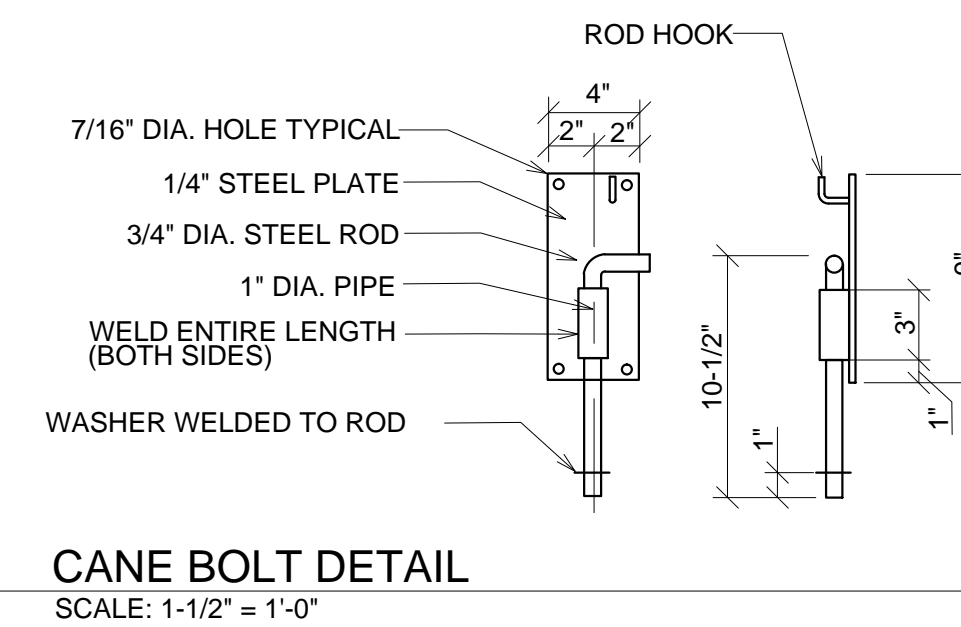
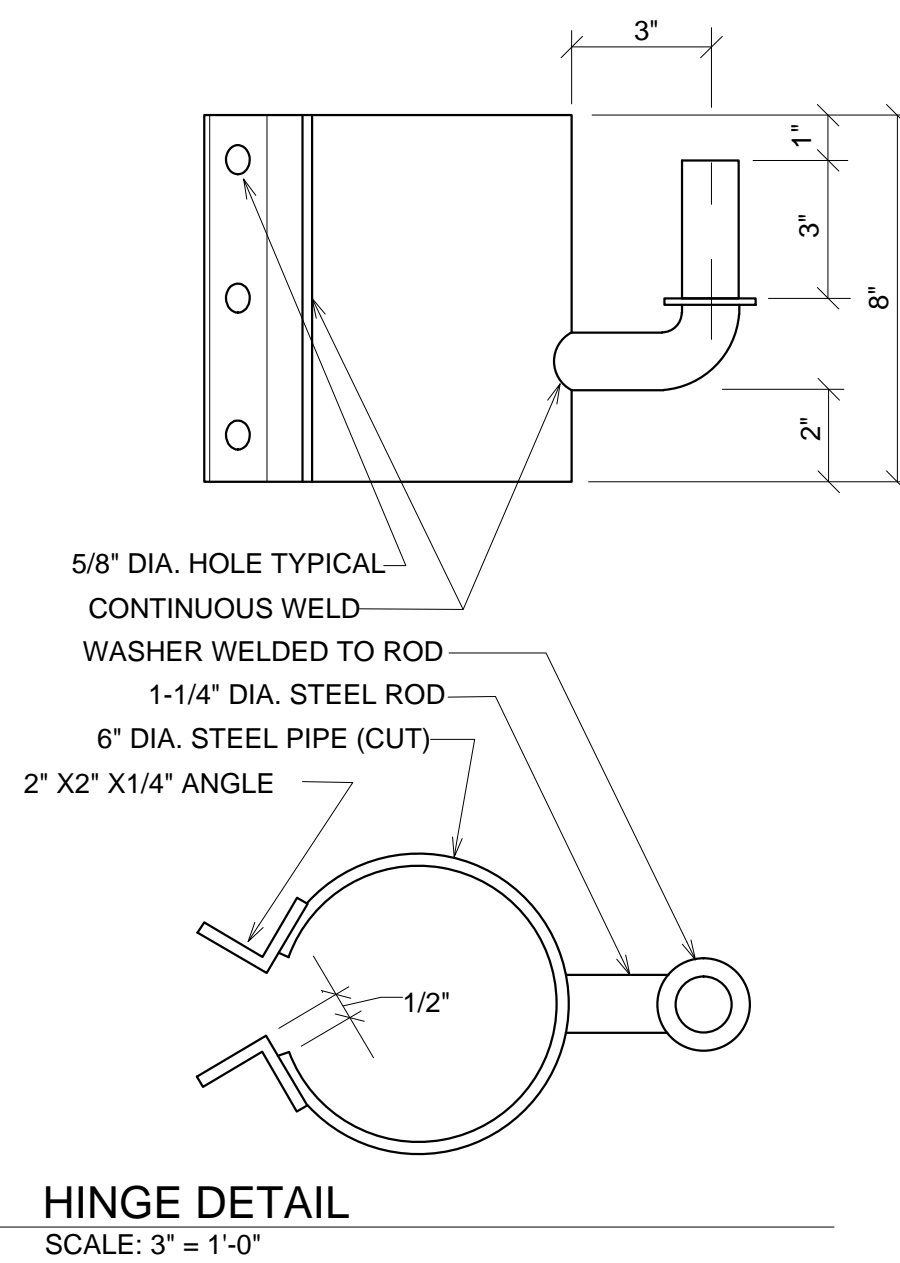
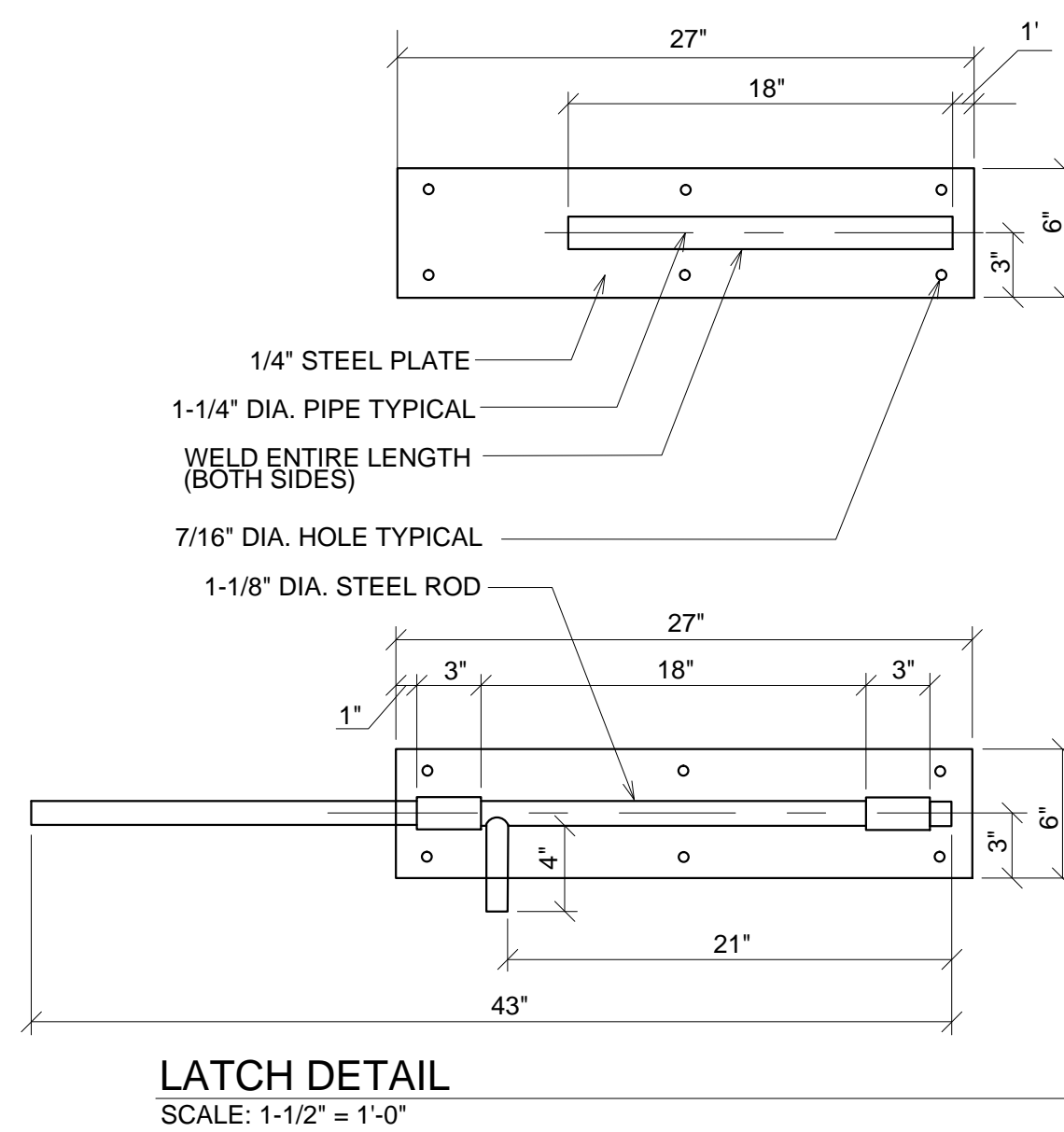
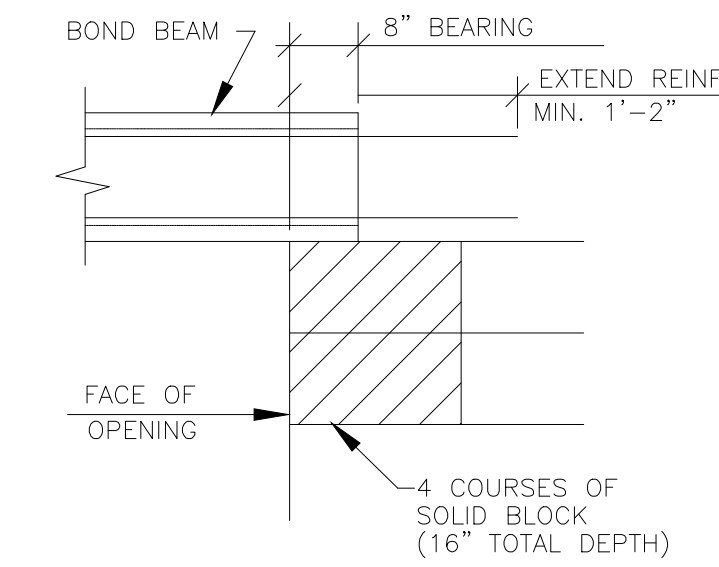

REV	DATE	DESCRIPTION	BY

PREPARED BY:

V3 Companies
 7325 James Avenue
 Woodridge, IL 60517
 630.724.9200 phone
 630.724.9202 fax
 www.v3co.com
 V3io, Vertere, Virtute... The Vision to Transform with Excellence™

PREPARED FOR:
McDonald's USA, LLC
 These drawings and specifications are the confidential and proprietary property of McDonald's USA, LLC and shall not be copied or reproduced without written authorization. The contract documents were prepared for a specific project and are not valid for any other project. Use of these drawings for reference or example on another project requires the services of properly licensed architects and engineers. Reproduction of the contract documents for reuse on another project is not authorized.

TITLE	TRASH CORRAL	DRAWN BY	CUB
SHEET NO.	SS-1.3	STD ISSUE DATE	10/21/16
DESCRIPTION	McDONALD'S - ORLAND PARK, ILLINOIS	REVIEWED BY	PJM
SITE ADDRESS	14445 S. LAGRANGE ROAD, ORLAND PARK, IL	DATE ISSUED	10/21/16
SHEET NO.	012-0280		

NOTE: SEE SHEET SS-1.2 FOR ADDITIONAL INFORMATION.

