

INTERGOVERNMENTAL AGREEMENT BY AND BETWEEN THE VILLAGE OF ORLAND PARK AND THE METROPOLITAN WATER RECLAMATION DISTRICT OF GREATER CHICAGO FOR THE DISTRIBUTION OF RAIN BARRELS

THIS INTERGOVERNMENTAL AGREEMENT (hereinafter the “Agreement”) entered into, by and between the Metropolitan Water Reclamation District of Greater Chicago, a unit of local government and body corporate and politic, organized and existing under the laws of the State of Illinois (hereinafter the “District”) and the Village of Orland Park, a municipal corporation and home rule unit of government organized and existing under Article VII, Section 6 of the 1970 Constitution of the State of Illinois (hereinafter the “Village”).

WITNESSETH:

WHEREAS, on November 17, 2004, the Illinois General Assembly passed Public Act 093-1049 (hereinafter the “Act”); and

WHEREAS, the Act declares that stormwater management in Cook County shall be under the general supervision of the District; and

WHEREAS, the Act, as amended, specifically authorizes the District to plan, implement, and finance regional and local activities relating to stormwater management in Cook County; and

WHEREAS, one component of the District’s stormwater management program includes green infrastructure, which hereinafter shall mean the range of stormwater control measures that use plant/soil systems, permeable pavement, stormwater harvest and reuse, or native landscaping to store, infiltrate, and/or evapotranspire stormwater and reduce flows to the sewer systems or to surface waters as more fully set forth at 415 ILCS 56/5; and

WHEREAS, the District has committed to developing an enhanced rain barrel distribution program (“Rain Barrel Program”), in conformance with Appendix E, Section II(A) of a certain consent decree entered into in United States, et al., v. Metropolitan Water Reclamation District of Greater Chicago, Case No. 1:11-cv-08859 (N.D. Ill. 2014)(“Consent Decree”), and the District’s formal commitment herein is intended to satisfy that obligation; and

WHEREAS, on April 17, 2014, the District’s Board of Commissioners adopted a Rain Barrel Program Policy (“Rain Barrel Program”) that is intended to satisfy certain requirements of the Consent Decree, and as part of the Policy, the District intends to develop a Municipal Distribution Network of its Rain Barrel Program as further set forth herein; and

WHEREAS, on May 21, 2015, the District’s Board of Commissioners adopted amendments to its Rain Barrel Program designed to encourage greater participation and distribution of rain barrels; and

WHEREAS, under the Rain Barrel Program, the District shall provide rain barrels designed to capture and use rain water to residences throughout its service area; and

WHEREAS, the distribution of rain barrels through the Rain Barrel Program may be approached more effectively, economically, and comprehensively, with the Village, and the District cooperating and using their joint efforts and resources; and

WHEREAS, the Village is located, wholly or partly, within the boundaries of Cook County; and

WHEREAS, the Intergovernmental Cooperation Act, 5 ILCS 220/1 *et seq.*, and Section 10 of Article VII of the Illinois Constitution, allow and encourage intergovernmental cooperation; and

WHEREAS, on May 21, 2015, the District's Board of Commissioners authorized the District to enter into an intergovernmental agreement, in substantially the same form as this intergovernmental agreement, with units of local government throughout the District's service area; and

WHEREAS, on Jan 18, 201⁶, the Village's Board of Trustees authorized the Village to enter into an intergovernmental agreement with the District; and

NOW THEREFORE, in consideration of the matters set forth, the mutual covenants and agreements contained in this agreement and, for other good and valuable consideration, the Village and District hereby agree as follows:

ARTICLE 1. INCORPORATION OF RECITALS

The recitals set forth above are incorporated herein by reference and made a part hereof.

ARTICLE 2. SCOPE OF WORK

1. The scope of this Agreement will include the District providing rain barrels, connection hardware and delivery at no cost, to the homes of residents in the Village (hereinafter the "Project"), as more fully set forth in Exhibit 1.
2. The District is expressly and intentionally not providing any assistance for the installation and operation of the rain barrel other than an instruction pamphlet, in a form substantially similar to the one attached hereto as Exhibit 2.
3. In order for the Village to be eligible to participate in this Rain Barrel Program, on behalf of its residents, the Village agrees to perform the following requirements:
 - a. place all rain barrel orders on behalf of residents using a form provided by the District; and

- b. obtain informed written consent from each resident receiving rain barrels allowing and agreeing to the District's limited access to their property solely for the purpose of delivering the rain barrel(s); and
- c. within one year of the date of this Agreement, the Municipality shall report back to the District with the number of rain barrels distributed, and cooperate with the District in the conducting of a post installation survey.

The documents setting forth an explanation of the Rain Barrel Program and needing to be signed by the Village and its residents, prior to free rain barrels being distributed, are attached hereto as Exhibit 1. In order to encourage as wide a distribution of rain barrels as possible, the maximum number of rain barrels to be distributed per home is four.

4. The Village shall return to the District all rain barrels that were delivered by the District in connection with the Rain Barrel Program but for any reason whatsoever were not installed or were subsequently disconnected from a resident's home.

ARTICLE 3. PERMITS AND FEES

1. Federal, State, and County Requirements. In the event any federal, state or local permits are required, the Village shall obtain all such permits required by law in connection with the Rain Barrel Program, and shall assume any costs in procuring said permits. Additionally, the Village shall obtain all consents and approvals required by federal, state, and/or county regulations in connection with the Rain Barrel program, and shall assume any costs incurred in procuring all such consents and approvals.
2. Maintenance. The Village shall obtain any and all permits necessary for the performance of any maintenance work associated with the improvements in connection with the Rain Barrel Program, and in accordance with Article 5 of this Agreement.

ARTICLE 4. INSPECTION AND MAINTENANCE

The District shall have the right (including any necessary right of access) in conjunction with the Village to conduct a joint annual inspection of the installed rain barrels upon reasonable notice to the Village and the homeowner(s).

ARTICLE 5. EFFECTIVE DATE

This Agreement becomes effective on the date that the last signature is affixed hereto.

ARTICLE 6. DURATION

Subject to the terms and conditions of Article 2 and Article 10, Section 4, this Agreement shall remain in full force and effect for perpetuity.

ARTICLE 7. NON-ASSIGNMENT

Neither party may assign its rights or obligations hereunder without the written consent of the other party.

ARTICLE 8. WAIVER OF PERSONAL LIABILITY

No official, employee, or agent of either party to this Agreement shall be charged personally by the other party with any liability or expenses of defense incurred as a result of the exercise of any rights, privileges, or authority granted herein, nor shall he or she be held personally liable under any term or provision of this Agreement, or because of a party's execution or attempted execution of this Agreement, or because of any breach of this Agreement.

ARTICLE 9. INDEMNIFICATION

The Village shall defend, indemnify, and hold harmless the District, its Commissioners, officers, employees, and other agents ("District Party") from liabilities of every kind, including losses, damages and reasonable costs, payments and expenses (such as, but not limited to, court costs and reasonable attorneys' fees and disbursements), claims, demands, actions, suits, proceedings, judgments or settlements, any or all of which are asserted by any individual, private entity, or public entity against the District Party and arise out of or are in any way related to: (1) the distribution, installation and use of rain barrels through the Rain Barrel Program within the corporate limit of the Village within Cook County; or (2) the exercise of any right, privilege, or authority granted to the Village under this Agreement.

ARTICLE 10. REPRESENTATIONS OF THE VILLAGE

The Village covenants, represents, and warrants as follows:

1. By submitting an application on behalf of its residents for rain barrel(s), the Village represents that it has the full authority and permission from the homeowner(s) and that such permission includes:
 - a. the right of the District, or its vendor, to deliver the rain barrel(s) to the individual homeowner, including but not necessarily limited to reasonable access to the homeowner's real property for purposes of delivering the rain barrel(s); and
 - b. that the Village and the District may access the homeowner's property to conduct a joint annual inspection of the installed rain barrels upon reasonable notice to the recipient of the rain barrel(s).

2. The individuals signing this Agreement and all other documents executed on behalf of the Village are duly authorized to sign same on behalf of and to bind the Village;
3. The execution and delivery of this Agreement, consummation of the transactions provided for herein, and the fulfillment of the terms hereof will not result in any breach of any of the terms or provisions of or constitute a default under any agreement of the Village or any instrument to which the Village is bound or any judgment, decree, or order of any court or governmental body or any applicable law, rule, or regulation; and
4. The Village acknowledges and accepts that the Rain Barrel Program being offered by the District is a voluntary program, wherein the Village residents are receiving complimentary rain barrels and as such, the District may discontinue the Rain Barrel Program at any time, without notice and without obligation to provide any additional rain barrels.

ARTICLE 11. REPRESENTATIONS OF THE DISTRICT

The District covenants, represents, and warrants as follows:

1. The District has full authority to execute, deliver, and perform or cause to be performed this Agreement;
2. The individuals signing this Agreement and all other documents executed on behalf of the District are duly authorized to sign same on behalf of and to bind the District; and
3. The execution and delivery of this Agreement, consummation of the transactions provided for herein, and the fulfillment of the terms hereof will not result in any breach of any of the terms or provisions of or constitute a default under any agreement of the District or any instrument to which the District is bound or any judgment, decree, or order of any court or governmental body or any applicable law, rule, or regulation.

ARTICLE 12. DISCLAIMERS

This Agreement is not intended, nor shall it be construed, to confer any rights, privileges, or authority not permitted by Illinois law. Nothing in this Agreement shall be construed to establish a contractual relationship between the District and any party other than the Village.

ARTICLE 13. WAIVERS

Whenever a party to this Agreement by proper authority waives the other party's performance in any respect or waives a requirement or condition to performance, the waiver so granted, whether express or implied, shall only apply to the particular instance and shall not be

deemed a waiver for subsequent instances of the performance, requirement, or condition. No such waiver shall be construed as a modification of this Agreement regardless of the number of times the performance, requirement, or condition may have been waived.

ARTICLE 14. SEVERABILITY

If any provision of this Agreement is held to be invalid, illegal, or unenforceable, such invalidity, illegality, or unenforceability will not affect any other provisions of this Agreement, and this Agreement will be construed as if such invalid, illegal, or unenforceable provision has never been contained herein. The remaining provisions will remain in full force and will not be affected by the invalid, illegal, or unenforceable provision or by its severance. In lieu of such illegal, invalid, or unenforceable provision, there will be added automatically as part of this Agreement a provision as similar in its terms to such illegal, invalid, or unenforceable provision as may be possible and be legal, valid, and enforceable.

ARTICLE 15. DEEMED INCLUSION

Provisions required (as of the effective date) by law, ordinances, rules, regulations, or executive orders to be inserted in this Agreement are deemed inserted in this Agreement whether or not they appear in this Agreement or, upon application by either party, this Agreement will be amended to make the insertions. However, in no event will the failure to insert such provisions before or after this Agreement is signed prevent its enforcement.

ARTICLE 16. ENTIRE AGREEMENT

This Agreement, and any exhibits or riders attached hereto, shall constitute the entire agreement between the parties. No other warranties, inducements, considerations, promises, or interpretations shall be implied or impressed upon this Agreement that are not expressly set forth herein.

ARTICLE 17. AMENDMENTS

This Agreement shall not be amended unless it is done so in writing and signed by the authorized representatives of both parties.

ARTICLE 18. REFERENCES TO DOCUMENTS

All references in this Agreement to any exhibit or document shall be deemed to include all supplements and/or authorized amendments to any such exhibits or documents to which both parties hereto are privy.

ARTICLE 19. JUDICIAL AND ADMINISTRATIVE REMEDIES

The parties agree that this Agreement and any subsequent Amendment shall be governed by, and construed and enforced in accordance with, the laws of the State of Illinois in all respects, including matters of construction, validity, and performance. The parties further agree

that the proper venue to resolve any dispute which may arise out of this Agreement is the appropriate Court of competent jurisdiction located in Cook County, Illinois.

This Agreement shall not be construed against a party by reason of who prepared it. Each party agrees to provide a certified copy of the ordinance, bylaw, or other authority to evidence the reasonable satisfaction of the other party that the person signing this Agreement for such party is authorized to do so and that this Agreement is a valid and binding obligation of such party. The parties agree that this Agreement may be executed in quadruplicate.

The rights and remedies of the District or the Village shall be cumulative, and election by the District or the Village of any single remedy shall not constitute a waiver of any other remedy that such party may pursue under this Agreement.

ARTICLE 20. NOTICES

Unless otherwise stated in this Agreement, any and all notices given in connection with this Agreement shall be deemed adequately given only if in writing and addressed to the party for whom such notices are intended at the address set forth below. All notices shall be sent by personal delivery, UPS, Fed Ex or other overnight messenger service, first class registered or certified mail, postage prepaid, return receipt requested, or by facsimile. A written notice shall be deemed to have been given to the recipient party on the earlier of (a) the date it is hand-delivered to the address required by this Agreement; (b) with respect to notices sent by mail, two days (excluding Sundays and federal holidays) following the date it is properly addressed and placed in the U.S. Mail, with proper postage prepaid; or (c) with respect to notices sent by facsimile, on the date sent, if sent to the facsimile number(s) set forth below and upon proof of delivery as evidenced by the sending fax machine. The name of this Agreement i.e., INTERGOVERNMENTAL AGREEMENT BY AND BETWEEN THE VILLAGE OF ORLAND PARK AND THE METROPOLITAN WATER RECLAMATION DISTRICT OF GREATER CHICAGO FOR THE DISTRIBUTION OF RAIN BARRELS must be prominently featured in the heading of all notices sent hereunder.

Any and all notices referred to in this Agreement, or that either party desires to give to the other, shall be addressed as set forth in Article 20, unless otherwise specified and agreed to by the parties:

ARTICLE 21. REPRESENTATIVES

Immediately upon execution of this Agreement, the following individuals will represent the parties as a primary contact and receipt of notice in all matters under this Agreement:

For the District

Director of Maintenance & Operations
Metropolitan Water Reclamation District
100 East Erie Street
Chicago, Illinois 60611
Phone: (312) 751-7905
FAX: (312) 751-5681

For the Village

Village President
Village of Orland Park
14700 S. Ravinia Avenue
Orland Park, Illinois 60462
Phone: (708) 403-6140
FAX: (708) 403-6169

Each party agrees to promptly notify the other party of any change in its designated representative, which notice shall include the name, address, telephone number and fax number of the representative for such party for the purpose hereof.

IN WITNESS WHEREOF, the Metropolitan Water Reclamation District of Greater Chicago and the Village of Orland Park, the parties hereto, have each caused this Agreement to be executed in quadruplicate by their duly authorized officers, duly attested and their seals hereunto affixed.

VILLAGE OF ORLAND PARK

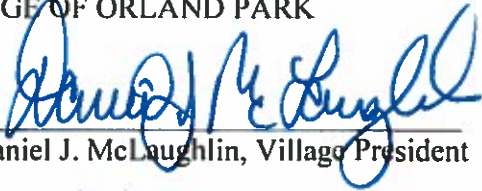
BY: 
Daniel J. McLaughlin, Village President

DATE: 1/18/16

ATTEST:

John C. Mehalek, Village Clerk

DATE: 1/18/16

METROPOLITAN WATER RECLAMATION DISTRICT OF GREATER CHICAGO

 2/4/16
Chairman of the Committee on Finance Date

 2/2/16
Executive Director Date

ATTEST:

 2.5.16
Clerk Date

APPROVED AS TO OPERATIONS, AND TECHNICAL MATTERS:

 2/1/16
Assistant Director of Maintenance & Operations Date

 2/1/16.
Director of Maintenance & Operations Date

APPROVED AS TO FORM AND LEGALITY:

 1/29/16
Head Assistant Attorney Date

 1/29/16
General Counsel Date

EXHIBIT 1

Metropolitan Water Reclamation District of Greater Chicago

Rain Barrel Program

A component of the District's Green Infrastructure Program

I. PROGRAM DESCRIPTION

Rain Barrels are a form of green infrastructure that are designed to capture and reuse rain water. The largest benefit of rain barrel use is achieved by disconnecting the roof runoff from the system and installing rain barrels to reuse water. Roofs comprise 41% of the impervious surface in Cook County. Many of these surfaces are directly connected to the public drainage system.

The goal of the Metropolitan Water Reclamation District of Greater Chicago's (District's) Rain Barrel Program is removing the direct load from entering the sewer system, reducing basement backups, and reducing combined sewer overflow volume, overland flooding, and infiltration and inflow. The District believes the value of keeping water out of the system will benefit the community.

The District's Rain Barrel Program will utilize three distribution networks throughout its service-delivery area to distribute and promote the use of rain barrels. These networks are described in Section II. Each rain barrel distributed will display a specially-designed label that summarizes the environmental benefits of using rain barrels (see Attachment A).

II. DISTRIBUTION NETWORKS

The three networks that will be utilized to distribute rain barrels are: municipalities, community groups/non-governmental organizations and campus- type facilities.

A. Municipalities

Cook County has 129 communities within the District's service area. Each community will be encouraged to adopt the Rain Barrel Program as its own. This program is contingent on funding approval by the Board of Commissioners on an annual basis. Until otherwise indicated, the Program will provide free rain barrels to residents who live in the District's service area.

Municipalities are required to enroll in this free program via an Intergovernmental Agreement (IGA). Once an IGA is signed, municipalities may order rain barrels, connection hardware, and delivery for their residents from the District's vendor at no cost to the municipality. The District will cover the cost of the rain barrels, the connection hardware and home delivery as the District has a contract with a vendor in place; the vendor will furnish and deliver rain barrels, and municipal partners will be

provided with an email address and telephone number that can be used to order the rain barrels for delivery to residents. Distribution will be limited to a maximum of four rain barrels per home.

The District will provide the following templates for municipalities to use:

- **Sample letter and rain barrel reservation form** – The letter and form can be adapted and mailed to residents; the form is designed to collect the information needed to place an order on the resident’s behalf.
- **Sample brochure that can incorporate your logo** – Upon request, the District will provide municipalities with a supply of brochures imprinted with their municipal logo.
- **Generic press release** – The language in this generic press release can be used in newsletters, on websites or submitted to local publications.

B. Community Groups/Non-Governmental Organizations

Cook County has many community groups and non-governmental organizations (NGOs) that work to educate residents about stormwater management, green infrastructure and environmental improvement. Community groups and NGOs will have access to the District's rain barrel program. To enroll in this free program, they will be asked to sign a Memorandum of Understanding (MOU). Once the MOU is signed, the community group/NGO may order rain barrels, connection hardware, and delivery for their constituents from the District at no cost to the community group/NGO.

In order to participate, the community group or NGO must:

- Submit a plan to the District describing the utilization of rain barrels;
- Provide detailed ordering information to the District ;
- Periodically ensure proper installation of rain barrels;
- Ensure proper education, care and maintenance of the rain barrels;
- Provide a follow-up report on rain barrel distribution. The report should include the following information:
 - email addresses of constituents receiving the rain barrel(s)
 - street addresses where rain barrels were installed
 - number of rain barrels installed, with a maximum of four rain barrels per home or location
 - a brief report of project successes and/or lessons learned in implementing the project.

C. Campus-Type Facilities

Campus-type facilities include: schools, municipal properties (i.e. town halls, libraries, park district facilities, fire and police stations, garage/outbuilding), churches,

community centers, senior centers, hospitals and clinics. The District will provide free rain barrels to any such facility committed to be a community partner and good steward of stormwater. The facility representative should contact the District regarding execution of a template IGA or MOU and to complete an appropriate application which shall include at a minimum:

- Size of campus
- Number of rain barrels requested
- Percent of downspouts intercepted
- Any other additional stormwater controls implemented on the site

After the rain barrels have been delivered and installed, the facility representative should submit a post-implementation plan or "As-Built" document that provides at minimum:

- addresses and locations where rain barrels were installed
- number of rain barrels installed
- a brief report of project successes and/or lessons learned in implementing the project.

III. MARKETING AND PROMOTION

In addition to providing technical assistance to residents, municipalities, community groups/non-governmental organizations and campus-type facilities on the proper use of rain barrels, a combination of tools will be provided by the District's Office of Public Affairs to promote and market rain barrels to the distribution networks. The tools include the District website, community outreach, public service announcements, email campaigns, press releases, promotion on social media, a rain barrel installation video and distribution of brochures.

Templates for applying for free rain barrels will be provided. In addition, the District can provide materials that utilize logos from the municipalities, community groups/non-governmental organizations and campus-type facilities for program purposes. The District will assign a District liaison to interested municipalities, community groups/non-governmental organizations and campus-type facilities. The liaison can provide assistance and direction during program implementation.

District Commissioners will also play a role in the marketing and promotion of the Rain Barrel Program. Commissioners may use and distribute rain barrels at community events as a means of educating and informing the public about the importance of green infrastructure, promoting the District's Rain Barrel Program, and instructing on proper installation. Upon request of each rain barrel for such events, Commissioners will provide the date, location, and purpose of the event for which the rain barrel(s) is/are being used, acknowledging by signature that the use and distribution is in compliance with the District's Ethics Ordinance policy on political activity.

IV. PROGRAM PERFORMANCE

The District's Maintenance and Operations Department will continue to administer the Rain Barrel Program in cooperation with Engineering and Public Affairs. An assigned resident engineer will administer the rain barrel contract, coordinate deliveries, and document distribution for reporting purposes. The resident engineer will collect the addresses and number of rain barrels delivered and installed. The Office of Public Affairs will document marketing, community outreach and technical assistance and submit this information to the resident engineer for inclusion in an annual report.

V. LABEL

A label will be affixed to every rain barrel distributed (see Attachment A). The label summarizes the environmental benefits of using rain barrels and green infrastructure.

VI. FORMS

Draft forms pertaining to this program are attached and will be modified to include information pertaining to the specific participating municipality, community group/non-governmental organization or campus-type facility:

1. Municipal and Community Group/NGO Ordering Instructions - Attachment B
2. Resident Application Form – Attachment C

Attachment A

SAVE WATER PREVENT FLOODING IMPROVE WATER QUALITY

55 GALLON
FROST-PROOF
RECYCLED

Rain Barrel

including:
MOSQUITO SCREEN
OVERFLOW DRAIN
SPIGOT

This rain barrel is part of the Metropolitan Water Reclamation District of Greater Chicago's green infrastructure program.
Green infrastructure helps prevent flooding and improve water quality by keeping clean water out of the sewer system.



Use water from your rain barrel to wash your car, water your garden or lawn, or wash your pet. **Do not drink water from a rain barrel.**
For installation instructions and more information, visit mwrcl.org.
Find the MWRD on Facebook and Twitter and show off your rain barrel!

Attachment B



MWRD Rain Barrel Program

Municipal and Community Group/Non-Governmental Organization Ordering Instructions

Municipalities and Community Groups/Non-Governmental Organizations in the District's service area may order free rain barrels for their residents.

To qualify for free rain barrels, residents must either live in a municipality that has signed an Intergovernmental Agreement with the District or request them through an organization that has signed a Memorandum of Understanding with the District.

If the resident meets the above criteria, then the municipality or community group/non-governmental organization may call 815-735-9583 or email sales@upcycle-products.com to order rain barrels*; please write **MWRD Rain Barrel Program** in the subject line.

The following resident information will be required for delivery:

Name _____

Address _____

Phone number _____

Email address _____

Number of rain barrels _____

Color requested (*indicate #*) ___ Terra Cotta ___ Blue ___ Black ___ Gray

Desired delivery days/times _____

*A maximum of four rain barrels may be ordered per location.
Bulk deliveries will continue to be made to organizations and agencies wishing to purchase rain barrels at cost from the District.

Need more information? Visit www.mwrd.org or call (312) 751-6633.

Free Rain Barrel Program Municipal Application Form for Residents

We are pleased to offer free rain barrels to our residents. Please complete the information needed for delivery.

Resident's information:

Name: _____
(Please print)

Home address: _____

Phone number: _____

Email address: _____

Number of rain barrels requested: _____

Rain Barrel Color (indicate #): ___ Terra Cotta ___ Blue ___ Black ___ Gray

Desired delivery days/times: _____

EXHIBIT 2

Installing Your Rain Barrel

Required tools: Hacksaw, tape measure, goggles, gloves, pen or pencil

Recommended materials: 7'-10' garden hose, concrete blocks and/or pressure treated wood

1. Place the Barrel

Rain barrels need to be located near a downspout and on level, pervious (water-absorbing - not paved) ground. Your rain barrel will overflow during heavy rain. Be sure you can direct overflow to pervious ground and away from your (and your neighbor's) home.

Placing your rain barrel on a stable platform will help increase water pressure and make it easier to use a watering can or bucket. Concrete blocks or pressure-treated wood work well for platforms. A full rain barrel weighs approximately 500 pounds, so make sure the platform is sturdy!

If you have a favorite watering can, adjust your platform to make sure it will fit comfortably under the spigot.

2. Measure and Cut

Once your rain barrel is in place, position the flexible elbow (included with your rain barrel) on the barrel and next to the downspout to determine where to cut. The elbow should be aimed at the screened opening on the top of the rain barrel, and the downspout must be inserted about 2" into the elbow. For most installations, it works well to cut the downspout about 8" above the top of the barrel. Keep in mind that the downspout will need to be inserted a couple inches into the connecting elbow. Mark the downspout with a pen or pencil where you will be cutting it.

Once you are sure where to cut, put on your safety goggles and gloves and cut the downspout with a hacksaw.

3. Connect

Connect the flexible elbow to the cut downspout by inserting the downspout into the elbow and positioning it so water will flow into your rain barrel. Connect a garden hose to the overflow fitting and direct it away from your house. Depending on the location of your rain barrel and your yard, this hose may need to be at least 7'-10' long.

Cap off the old downspout location on the ground to prevent it from becoming an animal's nest or clogged with debris.

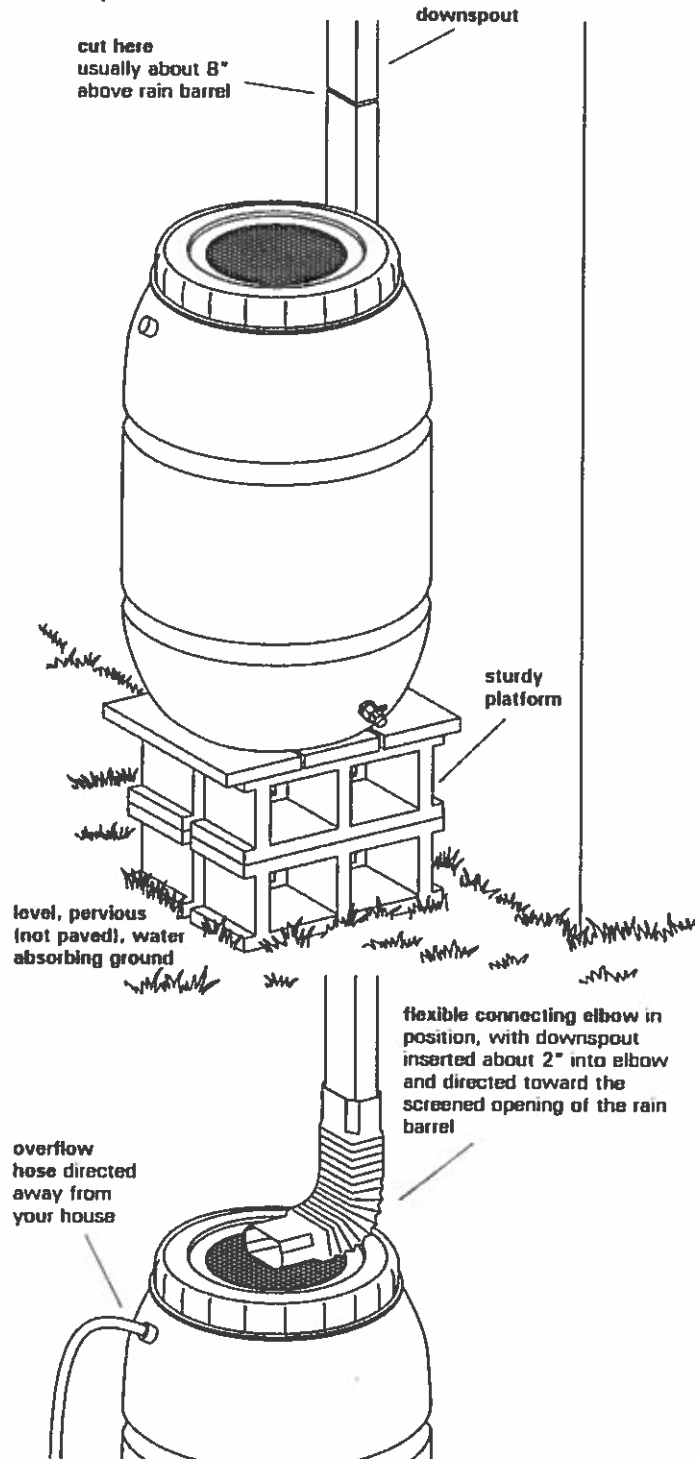

Metropolitan Water Reclamation District of Greater Chicago

mwrd.org

Disclaimer: With proper installation, maintenance and use, your rain barrel should function properly. The Metropolitan Water Reclamation District of Greater Chicago assumes no liability for the installation, maintenance or use of your rain barrel. We are not responsible for any rain barrel malfunction, property damage or injury associated with your rain barrel malfunction, property damage or injury associated with your rain barrel, its accessories or contents.

Maintaining and Using Your Rain Barrel

You can use rain barrel water to wash your car, water your lawn, or clean work boots and tools. Rain barrel water is naturally free of chlorine, lime, and calcium, and some gardeners swear their plants prefer it.

Rain barrel water is runoff from your roof, so do not drink it or use it for bathing! Disconnect your rain barrel if you need to use a moss killer on your roof. Wait for a few rainy days before reconnecting your rain barrel to allow the moss killer to rinse away. Do not use rain barrel water on plants if your home has a copper roof or gutters.

Oh No, Overflow!

Don't worry, your rain barrel is meant to overflow once it is full. Overflow water will spill from the opening on the top and the overflow fitting. Connect a hose to the overflow fitting to direct the water away from your house. You can also connect a second rain barrel to the first one using the included connecting hose and double the amount of water captured before it overflows.

Check on your rain barrel when it is raining to make sure the overflow is not causing flooding or flowing into your neighbor's property. If your rain barrel is properly installed on a pervious surface, overflow water should be absorbed into the ground. If you see water pooling on your property, consider installing a rain garden, which is a type of landscaping designed to absorb water.

Regular Maintenance

Regularly check your gutters, downspouts, rain barrel water intake screen, rain barrel mosquito screen and rain barrel spigot for leaks, obstructions or debris. Also, confirm that the lid is secure so children and animals cannot fall into the rain barrel.

Winterizing

Drain your rain barrel before temperatures drop below freezing and keep the spigot open in the winter so water does not accumulate and freeze.

You can also turn it upside down or bring it inside to ensure no water accumulates in the barrel.

Preventing Mosquitoes

Your rain barrel comes with a mosquito-proof screen under the lid. When the mosquito netting is intact, and there are no leaks where mosquitoes can enter the barrel, your rain barrel should be mosquito-free.

Remove accumulated water from the top of the barrel every 3-4 days during the rainy season. Mosquitoes need at least 4 days of standing water to develop larvae.

If you believe mosquitoes may be breeding in your rain barrel, empty it completely and let it dry out to kill all mosquitoes.

If you want to customize the appearance of your rain barrel, you can

Paint Your Rain Barrel

Follow these steps to paint your rain barrel:

1. Wash it thoroughly with soapy water to remove any dust or dirt.
2. Once the barrel is dry, apply a plastic primer designed to adhere to polyethylene plastic. Follow the instructions for the primer, including safety precautions.

Note: Don't skip this step. Primer is important! Paint will not stick to a rain barrel without primer, and house paint primers will not adhere well to rain barrel plastic.

3. Gently buff the primer surface with fine sandpaper to remove any glossy areas.
4. Paint the barrel with artist's acrylic paint. Acrylic paint is durable and won't chip or crack as easily as other paints.
5. Allow several days for the paint to dry completely and apply a clear spray sealant to protect your artwork. Follow the instructions for the spray sealant, including safety precautions. This will protect your work of art from the elements.