

ALL CONCEPTS INCLUDED IN THIS PLAN ARE THE PROPERTY OF BLACK CREEK CANYON, INC. UNTIL RELEASED IN WRITING BY BLACK CREEK CANYON, INC.

Black Creek Canyon, Inc.
 P.O. Box 54
 Lockport, IL 60441-0549
 phone 708-645-7900
 fax 708-645-7902
 www.blackcreekcanyoninc.com

STONE & LAND, LLC
 LANDSCAPE ARCHITECTURE
 630.779.7897
 www.stoneandland.com

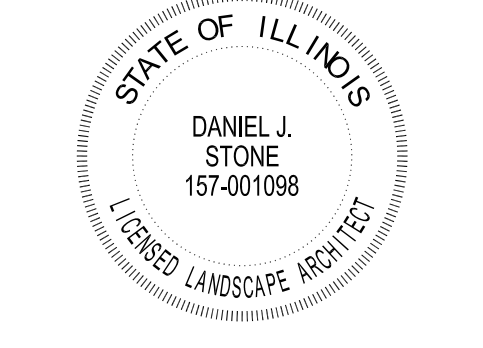

OFFICE BUILDING RENOVATION
 SHETH DERMATOLOGY
 913 W. 151st Street
 ORLAND PARK, ILLINOIS 60462

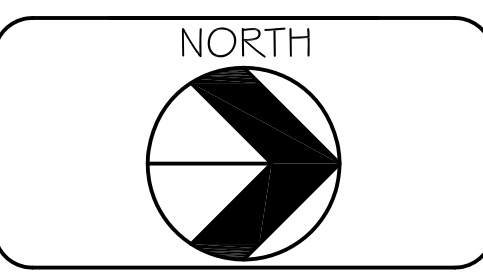
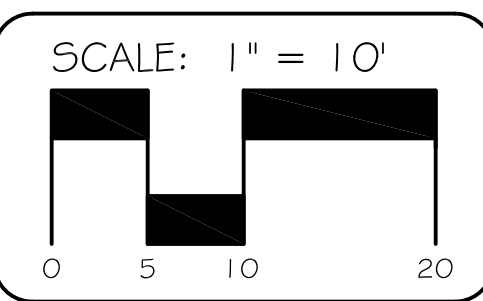

PROJECT NO: _____

DRAWN BY: DJIS

DATE: 3 OCT 2015

REVISIONS:
 1 notes, tree preserve 10/16/2015

LANDSCAPE PLAN

SHEET NO:
 LI
 1 of 2

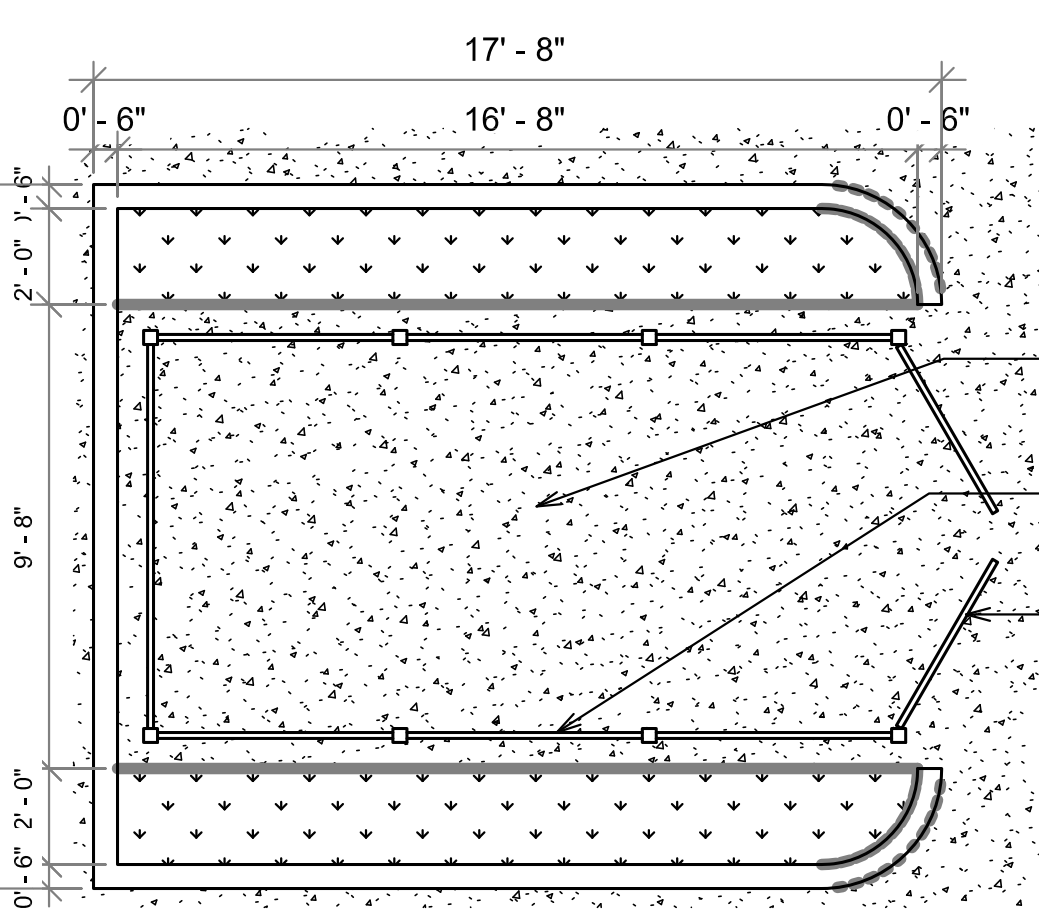
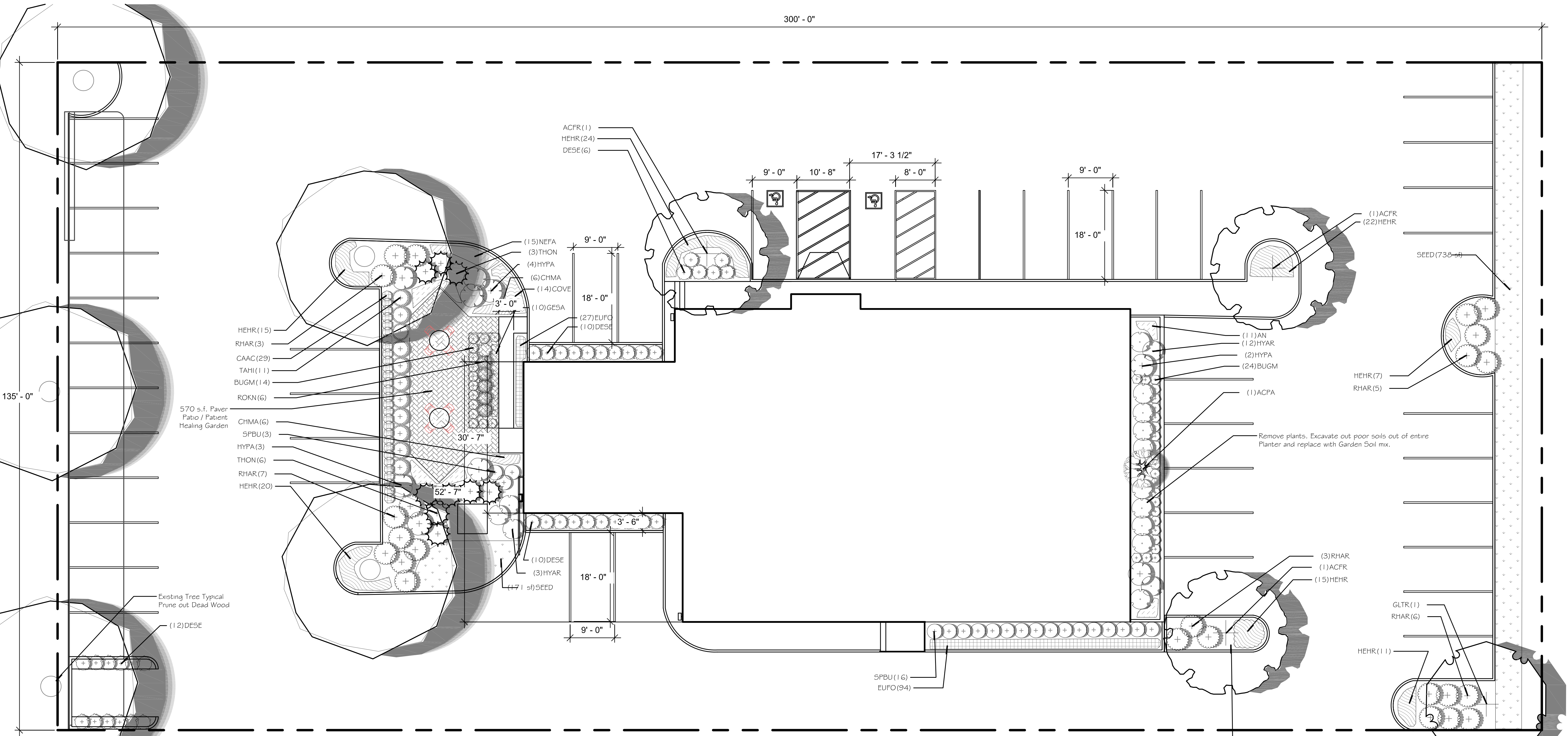

TRASH ENCLOSURE
 1/4" = 1'-0"

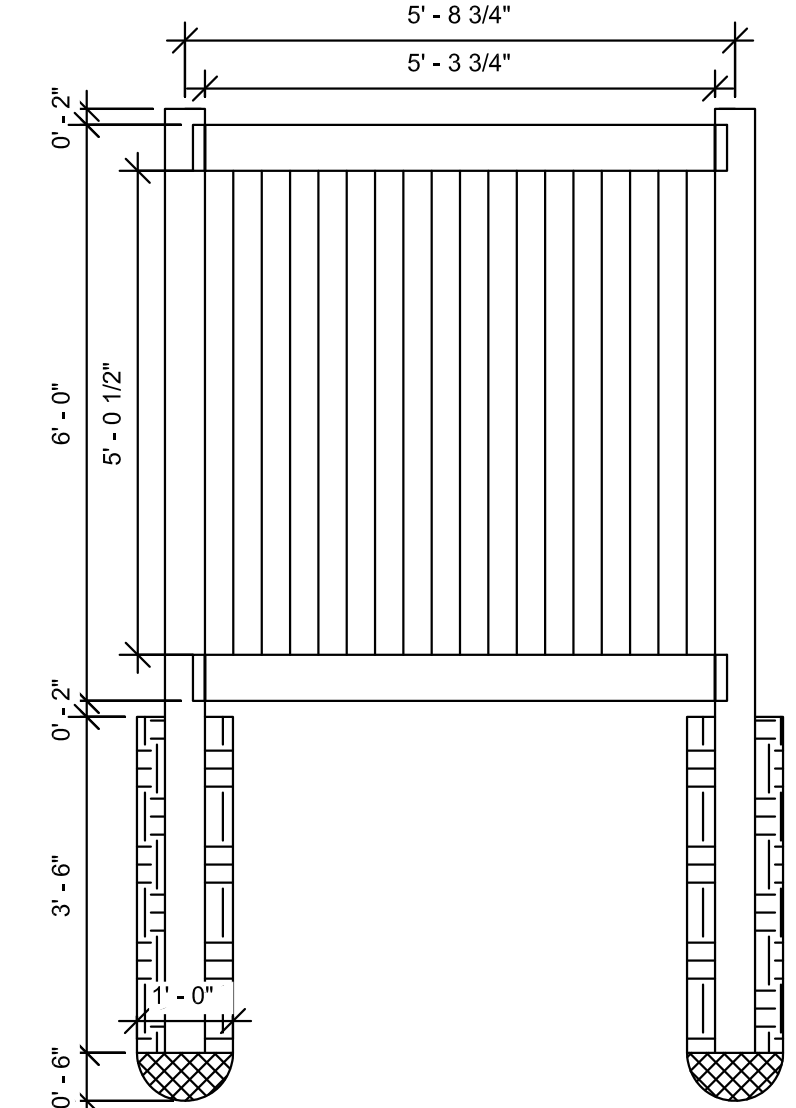

FENCE POST DETAIL
 1/2" = 1'-0"

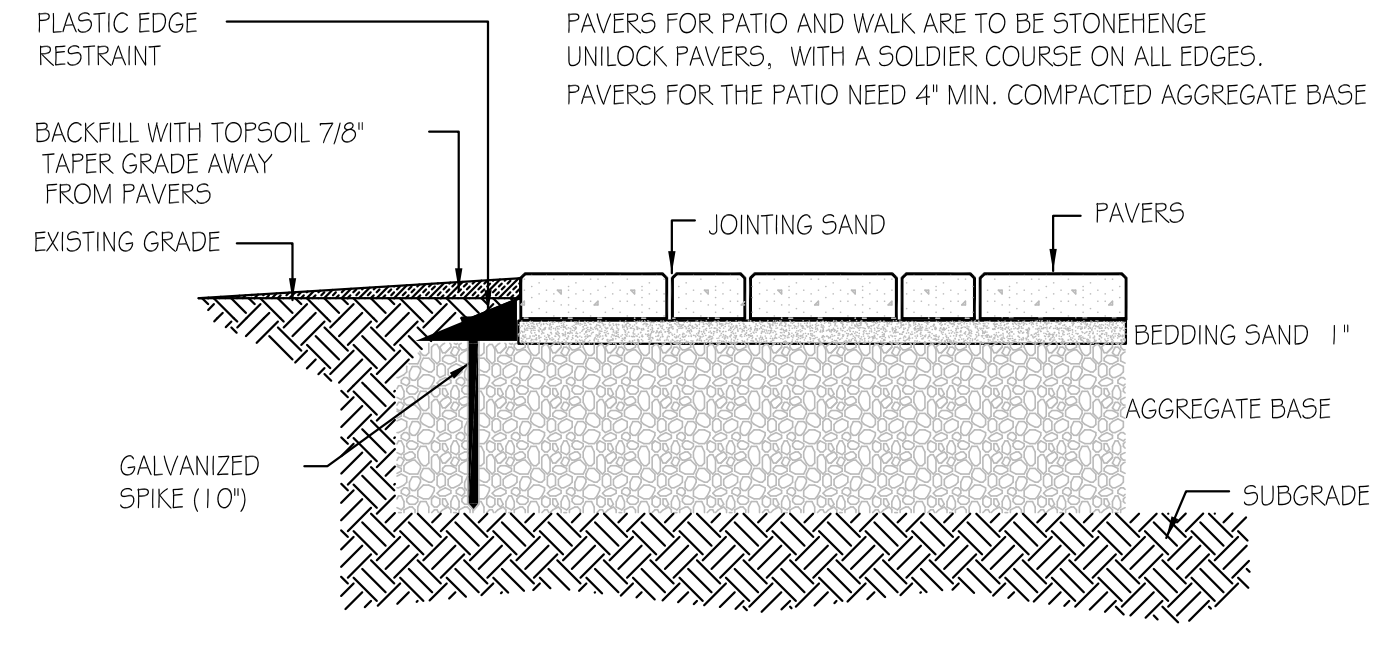

PAVER DETAIL
 1/8" = 1'-0"

PLANT SCHEDULE

TREES	QTY	BOTANICAL NAME	COMMON NAME	CONT	CAL	SIZE
ACFR	3	Acer freemanii 'Jeffersred'™ TM	Autumn Blaze Maple	B # B	2.5' Cal	
ACPA	1	Acer palmatum	Japanese Maple	15 gal		
GLTR	1	Gleditsia tnaacanthos var. inermis 'Skycole'™ TM	Skyline Thornless Honey Locust	B # B	2.5' Cal	
THON	9	Thuja occidentalis 'Nigra'	Nigra Cedar	B # B		5' Ht.
SHRUBS	QTY	BOTANICAL NAME	COMMON NAME	CONT		
BUGM	36	Buxus microphylla koreana 'Green Gem'	Green Gem Boxwood	24" Ht.		
DESE	36	Diervilla sessilifolia	Bush Honeysuckle	5 gal		
HYAR	15	Hydrangea arborescens 'Annabelle'	Annabelle Smooth Hydrangea	5 gal		
HYFA	9	Hydrangea paniculata 'Grandiflora'	PeaGee Hydrangea	5 gal		
RHAR	24	Rhus aromatica 'Gro-Low'	Gro-Low Fragrant Sumac	5 gal		
ROKN	6	Rosa hybrida 'Knockout'™ TM	Rosa 'RADrazz'	3 gal		
SPBU	19	Spiraea x bumalda 'Goldmound'	Gold Mound Spiraea	5 gal		
TAHI	11	Taxus x media 'Hicksii'	Hicks Yew	48" Ht., B#B		
GRASSES	QTY	BOTANICAL NAME	COMMON NAME	CONT		
CAAC	29	Calamagrostis acutiflora 'Karl Foerster'	Feather Reed Grass	1 gal		
GROUND COVERS	QTY	BOTANICAL NAME	COMMON NAME	CONT		SPACING
AN	72	Annuals	Seasonal Color	4" pot		12" o.c.
CHMA	12	Chrysanthemum maximum superbum 'Becky'	Shasta Daisy	1 gal		18" o.c.
COVE	14	Coreopsis verticillata 'Moonbeam'	Threadleaf Coreopsis	1 gal		18" o.c.
EUFO	121	Euonymus fortunei 'Colorata'	Purple-leaf Winter Creeper	3" pot		12" o.c.
GE5A	10	Geranium sanguineum 'Max Frei'	Dwarf Blood-red Cranesbill	1 gal		18" o.c.
HEHR	114	Hemerocallis hybrid 'Happy Returns'	Happy Returns Daylily	1 gal		18" o.c.
NEFA	15	Nepeta x faassenii 'Walkers Low'	Walkers Low Catmint	1 gal		18" o.c.
SOD/SEED	QTY	BOTANICAL NAME	COMMON NAME	CONT		SPACING
SEED	909 sf	Turf Seed	Blue Grass Blend	seed		

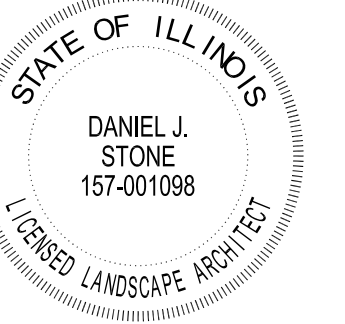

OFFICE BUILDING RENOVATION
 SHETH DERMATOLOGY
 913 W. 151st Street
 ORLAND PARK, ILLINOIS 60462

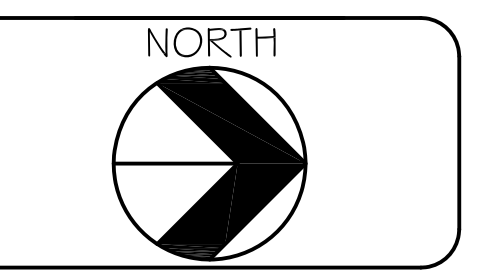
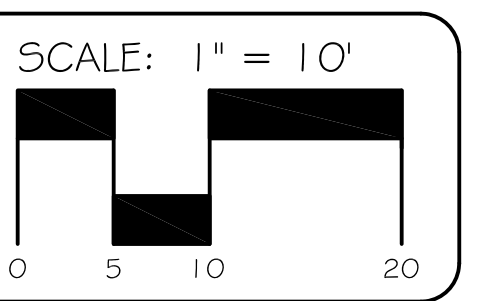

PROJECT NO: _____

DRAWN BY: DJIS

DATE: 3 OCT 2015

REVISIONS:

1	notes, tree preserve	10/16/2015

TREE PRESERVATION PLAN

SHEET NO:
L2
 2 of 2

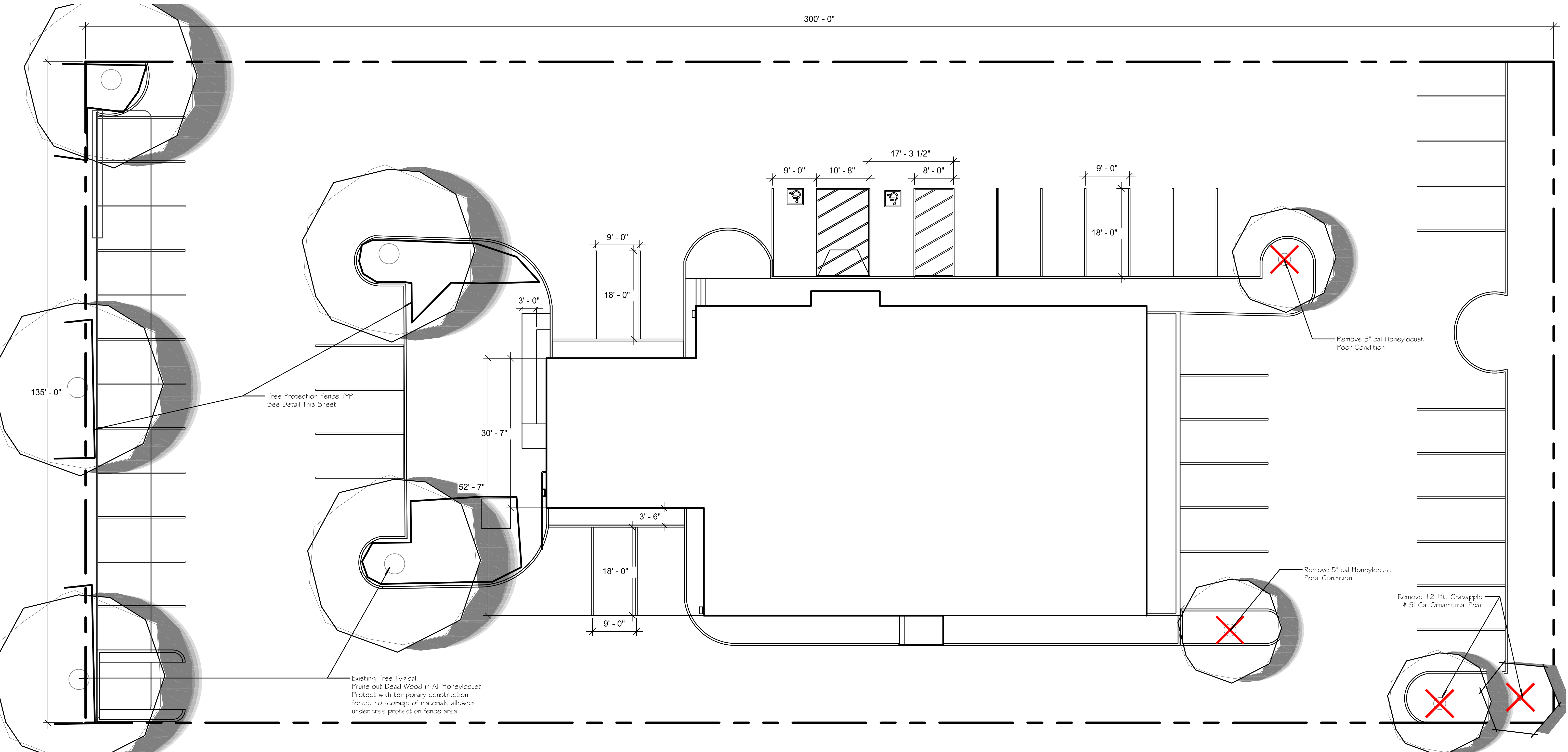

- Species and sizes of plants listed in the plant list are subject to availability at time of installation. If substitutions are necessary, the landscape contractor shall submit all requests to the owner for approval.
- All underground utilities are to be located prior to digging. Call J.U.L.I.E. at 811 or 1.800.892.0123. If utilities or other obstructions are discovered to conflict with grading or plant placement, notify the landscape architect so that adjustments can be made.
- Backfill trees and shrubs with amended topsoil mixed thoroughly outside of the planting pit. Mulch trees and shrubs with 2" hardwood mulch and pull mulch away from the base.
- Perennial and groundcover beds are to be amended with 2" planting mix and tilled in to a depth of 8". Perennials and groundcovers are to be top dressed with 1" mulch.
- Provide positive drainage flow. Do not obstruct the natural or engineered drainage flow patterns. Notify the landscape architect or owner of any drainage concerns.
- The landscape contractor shall take all precautions to protect existing plants, lawn, and paved areas to remain. Any damage to these areas shall be repaired or replaced by the landscape contractor. Damaged lawn areas are to be re-graded and restored with salt tolerant sod.
- All bed edges are to be well shaped 'spade cut' edges, 3" deep, formed in lines or curves as shown on the drawings.
- Apply a pre-emergent for grassy and broadleaf weeds to all shrub beds and tree rings. Do not apply pre-emergent to beds of groundcovers or annuals.
- The general contractor is to provide finished grade to a tenth of a foot with sufficient quality top soil. The landscape contractor is to provide fine grade only.
- For details pertaining to TREE PRESERVATION & REMOVALS, direct inquiries to the Village of Orland Park.

GENERAL NOTES

- NOTE: TREES TO BE PLANTED A MINIMUM OF FIVE FEET FROM UNDERGROUND UTILITIES AND TREES AND TEN FEET FROM ABOVE GROUND UTILITY STRUCTURES.
- NOTE: NOTIFY LANDSCAPE ARCHITECT OR VILLAGE OF CONFLICTS WITH EXISTING TREES OR UTILITIES THAT MAY REQUIRE FIELD ADJUSTMENTS TO PLANT LOCATIONS.

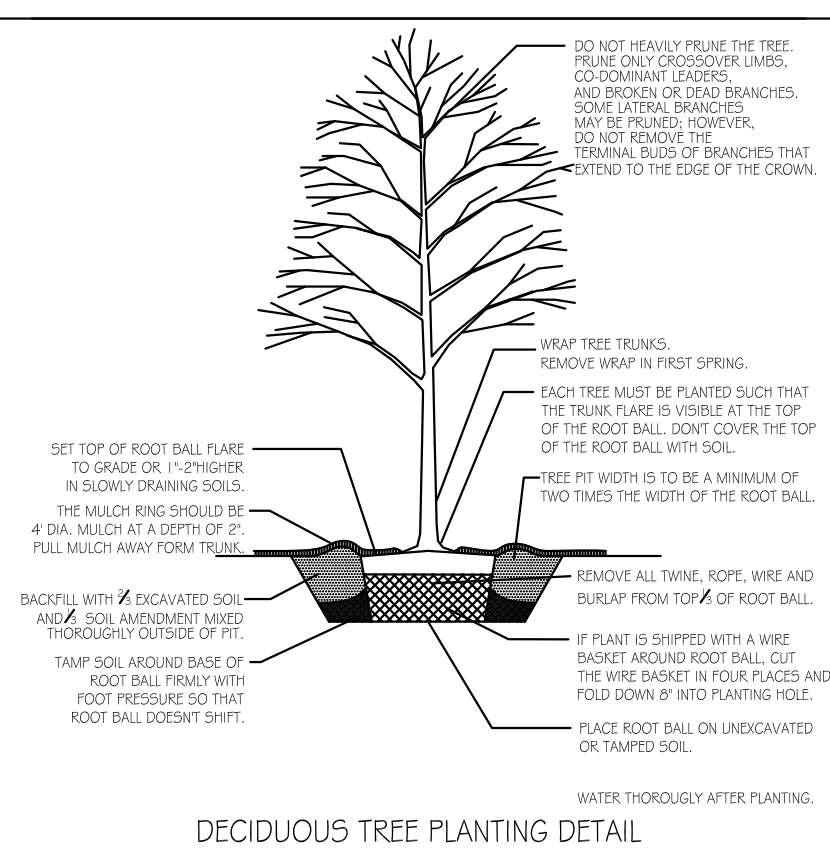

DECIDUOUS TREE PLANTING DETAIL

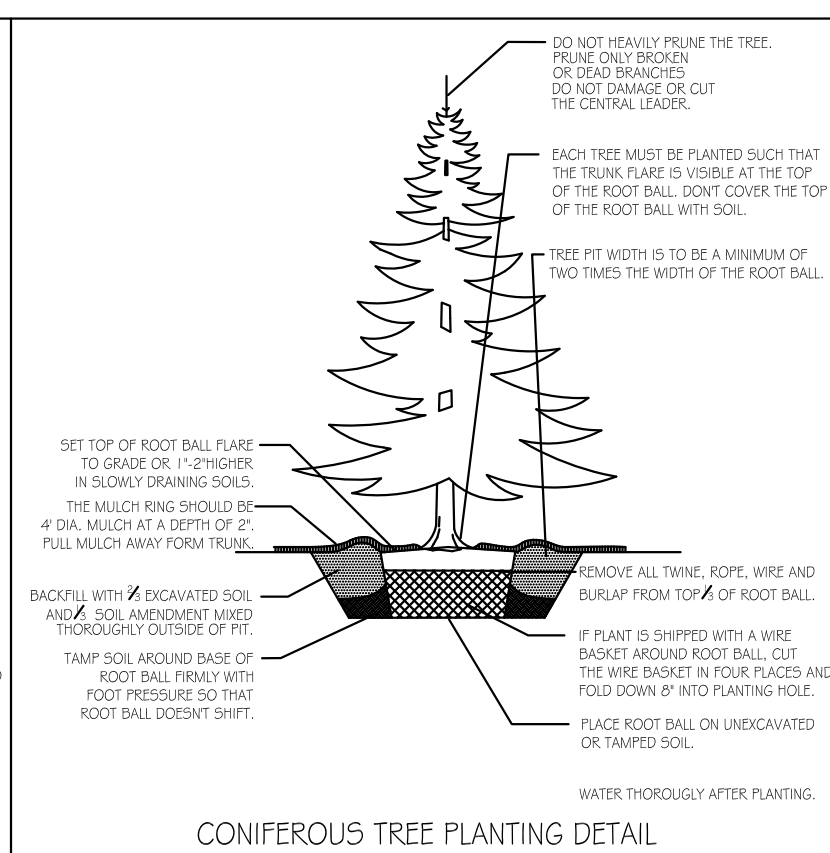

CONIFEROUS TREE PLANTING DETAIL

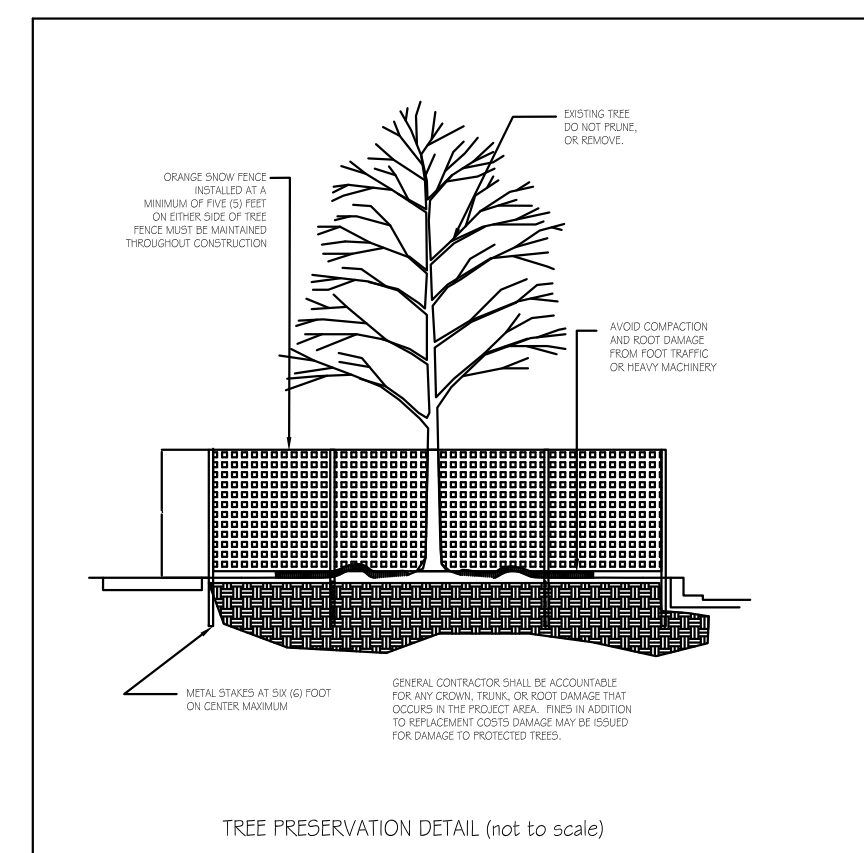

TREE PRESERVATION DETAIL (not to scale)

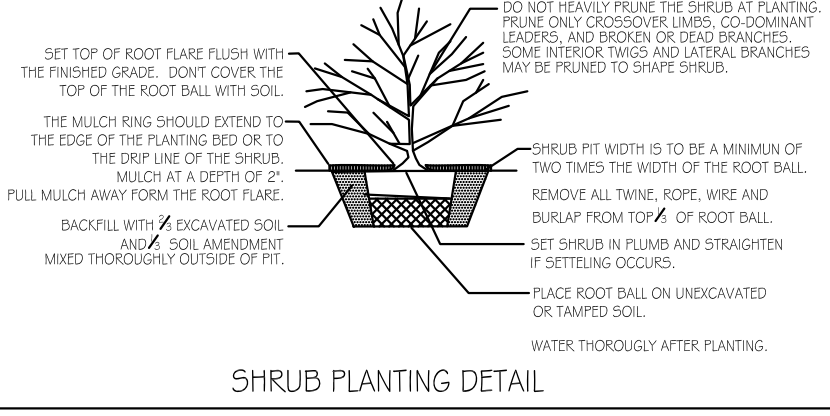

SHRUB PLANTING DETAIL

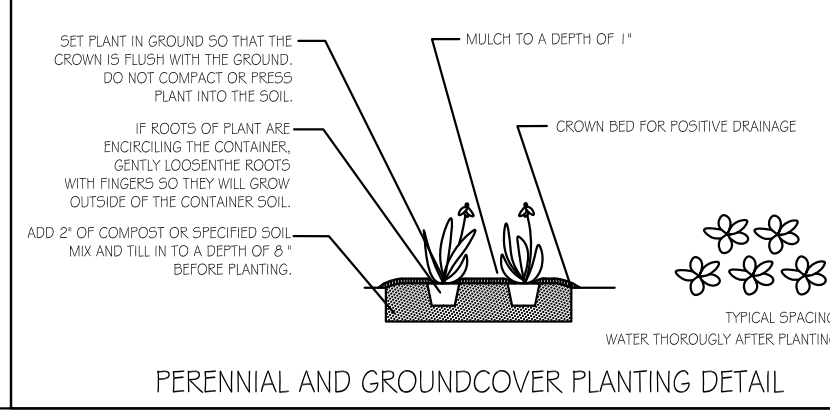

PERENNIAL AND GROUNDCOVER PLANTING DETAIL